SYLLABI-BOOK MAPPING TABLE

Educational Technology

Syllabi	Mapping in Book
Unit-I Meaning, nature and scope of Educational Technology; Components of Educational Technology—hardware, software; Systems approach in Educational Technology; Multimedia approach in Educational Technology.	Unit 1: Educational Technology: An Overview (Pages: 3-75)
Unit-II Concept of Communication Process; Classroom Communication: Verbal and Non-verbal communication; Observation Schedules of Classroom Interaction; Flanders’ Interaction Analysis Categories System (FIACS)	Unit 2: Communication (Pages: 77-125)
Unit-III Micro teaching- Definition, Skills involved in Micro teaching. Uses, effectiveness and Limitations of Micro teaching; Models of Teaching- Concept and Types, Uses and Limitations.	Unit 3: Microteaching (Pages: 127-170)
Unit-IV Teaching Aids—Psychology of Using Teaching Aids. Types of Teaching Aids—Non projected, Projected and Audiovisual Aids. Computer as Teaching Aid.	Unit 4: Teaching Aids (Pages: 171-205)
Unit-V Levels of teaching—Memory, Understanding and Reflective Programme—Linear and Branching.	Unit 5: Stages, Levels and Models of Teaching (Pages: 207-238)

CONTENTS

INTRODUCTION **1-2**

UNIT 1 EDUCATIONAL TECHNOLOGY: AN OVERVIEW **3-75**

- 1.0 Introduction
- 1.1 Unit Objectives
- 1.2 Meaning and Definition of Educational Technology
- 1.3 Nature of Educational Technology
- 1.4 Types of Educational Technology
 - 1.4.1 Teaching Technology
 - 1.4.2 Behavioural Technology
 - 1.4.3 Instructional Technology
- 1.5 Components of Educational Technology: Hardware and Software
 - 1.5.1 Hardware Approach
 - 1.5.2 Software Approach
- 1.6 Systems Approach in Educational Technology
 - 1.6.1 Systems Approach in Education
 - 1.6.2 Advantages of Systems Approach
 - 1.6.3 Role of the Teacher in Systems Approach
- 1.7 Multimedia Approach in Educational Technology
 - 1.7.1 Audio-Visual Aids
 - 1.7.2 Blackboard
 - 1.7.3 Charts
 - 1.7.4 Epidiascope
 - 1.7.5 Film Strip
 - 1.7.6 Map Study
 - 1.7.7 Microfilm
 - 1.7.8 Projector
 - 1.7.9 Reprographic Equipment
 - 1.7.10 Three-Dimensional Aids
 - 1.7.11 Radio's School Broadcast Programmes
 - 1.7.12 Educational Television (ETV) or Instructional Television (ITV)
- 1.8 Role and Significance of Educational Technology
- 1.9 Summary
- 1.10 Key Terms
- 1.11 Answers to 'Check Your Progress'
- 1.12 Questions and Exercises
- 1.13 Further Reading

UNIT 2 COMMUNICATION **77-125**

- 2.0 Introduction
- 2.1 Unit Objectives
- 2.2 Communication
 - 2.2.1 Communication Cycle
 - 2.2.2 Principles of Communication
- 2.3 Classroom Communication
 - 2.3.1 Verbal Communication
 - 2.3.2 Non-verbal Communication

- 2.4 Factors Affecting Classroom Communication
 - 2.4.1 Barriers to Effective Classroom Communication
 - 2.4.2 Guidelines for Better Communication in Classrooms
- 2.5 Observation Schedules of Classroom Interaction
 - 2.5.1 Importance of Observation
- 2.6 Flanders' Interaction Analysis Categories System (FIACS)
 - 2.6.1 Basic Theoretical Assumptions of Interaction Analysis
 - 2.6.2 Categories of Flanders' Interaction Analysis
 - 2.6.3 Observation of Classroom Events
 - 2.6.4 Construction of Interaction Matrix
 - 2.6.5 Interpretation of Interaction Matrix
 - 2.6.6 Advantages of Flanders' Interaction Analysis
 - 2.6.7 Disadvantages of Flanders' Interaction Analysis
- 2.7 Teaching
 - 2.7.1 Variables of Teaching
 - 2.7.2 Phases of Teaching
- 2.8 Teaching Machine
 - 2.8.1 History of Development of Teaching Machine
 - 2.8.2 Characteristics of Teaching Machine
 - 2.8.3 Constituent Parts of Teaching Machines
 - 2.8.4 Types of Teaching Machines
 - 2.8.5 Advantages and Disadvantages of Teaching Machines
- 2.9 Summary
- 2.10 Key Terms
- 2.11 Answers to 'Check your Progress'
- 2.12 Questions and Exercises
- 2.13 Further Reading

UNIT 3 MICROTEACHING

127-170

- 3.0 Introduction
- 3.1 Unit Objectives
- 3.2 Microteaching—Definition, Skills Involved in Microteaching
 - 3.2.1 Phases of Microteaching Procedure
 - 3.2.2 Microteaching Cycle
 - 3.2.3 Indian Model of Microteaching
 - 3.2.4 Teaching Skills Through Microteaching
 - 3.2.5 Advantages of Microteaching
 - 3.2.6 Disadvantages of Microteaching
- 3.3 Teaching Model
 - 3.3.1 Nature of Teaching Models
 - 3.3.2 Elements of a Teaching Model
 - 3.3.3 Types of Modern Teaching Models
 - 3.3.4 Glaser Model of Teaching or Basic Teaching Model
 - 3.3.5 Classroom Meeting Model
 - 3.3.6 Uses and Limitations of Teaching Models
- 3.4 Information Processing Models
 - 3.4.1 Models and Theories
- 3.5 Simulated Teaching
 - 3.5.1 Objectives of Simulated Teaching
 - 3.5.2 Educational Uses of Simulation
 - 3.5.3 Types of Simulation
 - 3.5.4 Procedure of Simulated Teaching

- 3.5.5 Teacher Training and Simulated Teaching
- 3.5.6 Precautions in Simulated Teaching
- 3.5.7 Advantages of Simulated Teaching
- 3.5.8 Disadvantages of Simulated Teaching
- 3.6 Summary
- 3.7 Key Terms
- 3.8 Answers to 'Check Your Progress'
- 3.9 Questions and Exercises
- 3.10 Further Reading

UNIT 4 TEACHING AIDS

171-205

- 4.0 Introduction
- 4.1 Unit Objectives
- 4.2 Teaching Aids for Teaching
 - 4.2.1 Psychology of Using Teaching Aids/Audio-visual Aids
- 4.3 Types of Teaching Aids
 - 4.3.1 Non-projected Aids
 - 4.3.2 Projected Aids
 - 4.3.3 Audio-visual Aids
 - 4.3.4 Computer as a Teaching Aid
- 4.4 Summary
- 4.5 Key Terms
- 4.6 Answers to 'Check Your Progress'
- 4.7 Questions and Exercises
- 4.8 Further Reading

UNIT 5 STAGES, LEVELS AND MODELS OF TEACHING

207-238

- 5.0 Introduction
- 5.1 Unit Objectives
- 5.2 Teaching vs. Training/Instruction/Indoctrination
 - 5.2.1 Teaching/Conditioning and Training
 - 5.2.2 Teaching and Instructions
 - 5.2.3 Teaching and Indoctrination
- 5.3 Levels of Teaching
 - 5.3.1 Memory Level of Teaching
 - 5.3.2 Understanding Level of Teaching
 - 5.3.3 Reflective Level of Teaching
- 5.4 Programme Instruction
 - 5.4.1 Steps for Development of Programmed Instruction
 - 5.4.2 Fundamental Principles
- 5.5 Types of Programmed Instruction
- 5.6 Summary
- 5.7 Key Terms
- 5.8 Answers to 'Check Your Progress'
- 5.9 Questions and Exercises
- 5.10 Further Reading

INTRODUCTION

Education is a very important and integral part of society that governs the social functioning. It deeply connects with the wants and ambitions of every society. This is the reason that education cannot remain unaffected by any social change that takes place around us. Hence, any advancement in technology has a direct or indirect impact on the methodology of education in the current scenario.

In general, there is active participation and involvement of radio, television, computers, machines, films, and now the Internet and multimedia, in providing education and educational material to students. This is referred to as educational technology. The significance of educational technology has increased due to its capability to achieve desired goals related to making education universal, preparing teachers and upgrading curricula in every phase of education.

Educational Technology (ET) is the efficient organization of any learning system adopting or adapting itself to methods, processes, and products to serve identified educational goals. This involves systematic identification of the goals of education, recognition of the diversity of learners' needs, the contexts in which learning will take place, and the range of provisions needed for each of these. The challenge is to design appropriate systems that will provide for and enable appropriate teaching-learning systems that could realise the identified goals. The key to meeting this challenge is an appreciation of the role of educational technology as an agent of change in the classroom, which includes not only the teacher and the teaching-learning process but also systemic issues like reach, equity, and quality.

Over the past decades, educational technology in India has taken two routes: The first involved a large number of experiments aimed at the qualitative improvement of schools, adopted the systems approach to analyse the problems plaguing the particular situation, and have evolved a range of solutions. These have included the development of flexible systems, alternative curricula, multilevel organization of classes; low-cost teaching-learning materials, innovative activities and continuous support systems for teacher training. While many of these experiments have demonstrated intrinsic merit, they have been restricted to pockets of intense practice and have failed to influence the larger school system. The second is government sponsored schemes such as the Educational Technology Scheme and the Computer Literacy and Studies in Schools (CLASS) and their present-day analogues, including partnerships with global players. This included the supply of radio-cum-cassette players, colour televisions, microcomputers, present-day computer labs, and even satellite-receiving terminals. These schemes have largely remained supply-driven, equipment-centred, and disseminative in design. Scant attention has been paid to the development of the entire support system that would establish educational technology as a reliable, relevant, and timely intervention, and despite clear indications of the necessity for this action.

This book discusses the meaning, scope, importance and objectives of educational technology. It also stresses upon the importance of evaluation and research

NOTES

NOTES

in the field of educational technology for its efficiency and effectiveness in producing and utilizing software, hardware and other materials. This book *Educational Technology*, introduces the students to different stages, levels and models of teaching as well which will further help in comprehending the concept of teaching-learning process better.

This book, *Educational Technology*, is written in a self-instructional format and is divided into five units. Each unit begins with an *Introduction* to the topic followed by an outline of the *Unit Objectives*. The content is then presented in a simple and easy-to-understand manner, and is interspersed with *Check Your Progress* questions to test the reader's understanding of the topic. A list of *Questions and Exercises* is also provided at the end of each unit, and includes short-answer as well as long-answer questions. The *Summary* and *Key Terms* section are useful tools for students and are meant for effective recapitulation of the text.

UNIT 1 EDUCATIONAL TECHNOLOGY: AN OVERVIEW

NOTES

Structure

- 1.0 Introduction
- 1.1 Unit Objectives
- 1.2 Meaning and Definition of Educational Technology
- 1.3 Nature of Educational Technology
- 1.4 Types of Educational Technology
 - 1.4.1 Teaching Technology
 - 1.4.2 Behavioural Technology
 - 1.4.3 Instructional Technology
- 1.5 Components of Educational Technology: Hardware and Software
 - 1.5.1 Hardware Approach
 - 1.5.2 Software Approach
- 1.6 Systems Approach in Educational Technology
 - 1.6.1 Systems Approach in Education
 - 1.6.2 Advantages of Systems Approach
 - 1.6.3 Role of the Teacher in Systems Approach
- 1.7 Multimedia Approach in Educational Technology
 - 1.7.1 Audio-Visual Aids
 - 1.7.2 Blackboard
 - 1.7.3 Charts
 - 1.7.4 Epidiascope
 - 1.7.5 Film Strip
 - 1.7.6 Map Study
 - 1.7.7 Microfilm
 - 1.7.8 Projector
 - 1.7.9 Reprographic Equipment
 - 1.7.10 Three-Dimensional Aids
 - 1.7.11 Radio's School Broadcast Programmes
 - 1.7.12 Educational Television (ETV) or Instructional Television (ITV)
- 1.8 Role and Significance of Educational Technology
- 1.9 Summary
- 1.10 Key Terms
- 1.11 Answers to 'Check Your Progress'
- 1.12 Questions and Exercises
- 1.13 Further Reading

1.0 INTRODUCTION

History has revealed that technology strengthens the hands of a teacher and makes his/her teaching more effective. Education has been benefitted by technology in various ways and at various levels. From both, sociological and the economic points of view, technology has made an impact on education training. Education could keep

NOTES

pace and avoid costs and uncertainties of invention, by merely following technological leads. Today, a number of institutions in developed and developing countries are offering courses through various communication technologies such as interactive TV, computer conferencing, the Internet and other modern media. Some distance education/open learning institutions in developing countries now are also offering courses electronically. As a result, a large number of learners are pursuing their studies through technology.

In such conditions it becomes essential for all those in the field of education to be familiar with the nuances of the use of technology in education. Besides it is well known that some teachers teach better by utilizing new methods and techniques, whereas others prefer old methods. Over the years, many techniques, methods and equipment have been developed by teachers and researchers to make the process of learning effective. This process of developing and using scientific methods, media and techniques for enhancing the effectiveness of teaching and learning, is essential for educational technology. In this unit, you will be able to define educational technology, assess the scope and nature of educational technology and recognize the various forms of educational technology.

1.1 UNIT OBJECTIVES

After going through this unit, you will be able to:

- Discuss the concept of educational technology
- Explain the nature of educational technology
- List the different types of educational technology
- Analyse the components of educational technology
- Explain the contribution of the systems approach in the field of education
- Evaluate the multimedia approach in educational technology
- Discuss the role of the teacher in school television programmes
- Evaluate the role and significance of educational technology

1.2 MEANING AND DEFINITION OF EDUCATIONAL TECHNOLOGY

The 21st century has been named as the ‘age of knowledge’ and there is no way in which one can deny the role of technology in different aspects of our lives. Like other fields, education too has been deeply impacted by technological revolution. This interface of education and technology is popularly known as educational technology. Some associate the term ‘educational technology’ solely with technical equipment and media of education, such as overhead projectors, television, and computers. There are others who believe that educational technology involves a scientific and systematic analysis of the teaching—learning process with an objective to maximize its effectiveness.

Before going further, it is essential to understand the word 'technology'. This word is taken from the Greek word *technología*, which means an art and is related to skill and dexterity. Generally, the term 'technology' denotes the systematic application of the knowledge of sciences to practical tasks in industry. Technology can refer to material objects like machinery or hardware and also comprise more themes, including systems, methods of organization and techniques.

In context of educational technology, D. Randy Garrison (1989) opines: 'Technology will be viewed here as having both, a process (software) and a product (hardware) component, where process is the creative application of knowledge of purposeful activities. A subset of hardware is media, where media are the devices used to distribute information'. Thus, educational technology is a wider concept of the word 'technology'. Further, it will be wrong to confuse the term 'teaching' with the process of teaching or instructing, or educating, or provision of knowledge or engineering. This creation of education does not compromise and has very positive future prospects. For all those who are constantly engaged in the pursuit of knowledge otherwise, it will remain destructive to the welfare of free society.

A large number of different groups and individuals have defined 'educational technology' in many ways, over a period of time. A few of the notable definitions are as follows:

- According to Finn (1962), 'educational technology is a process, an attitude, a way of thinking about certain classes of problems.'
- Lumsden (1964) arrived at two meanings of educational technology, viz., Educational Technology-I (ET-I) and Educational Technology-II (ET-II). ET-I refers to the application of engineering principles of technology to instrumentation, useful in the process of teaching. ET-II refers to the application of behavioural science to improve instruction.
- The National Council for Educational Technology (1967) has defined educational technology as 'the development, application and evaluation of systems, techniques and aids to improve the process of human learning'.
- According to G. O. M. Leith, 'Educational technology is the application of scientific knowledge and learning and the conditions of learning, to improve the effectiveness and efficiency of teaching and training. In the absence of scientifically established principles, educational technology implements the techniques of empirical testing to improve learning situation'.
- According to S. K. Mitra, 'educational technology can be conceived as a science of techniques and methods by which educational goals could be realized'.
- According to S. S. Kulkarni, 'educational technology may be defined as the application of the laws as well as recent discoveries of science and technology to the process of education'.
- According to D. Unwin, 'educational technology is concerned with the application of modern skills and techniques to the requirements of education and training. This includes the facilitation of learning by manipulation of media

NOTES

NOTES

and methods and the control of environment in so far as this reflects on learning’.

- According to *Shiksha Paribhasha Kosh* (1978), educational technology has the following meanings:
 - (i) It is the use of those scientific theories and principles during the formulation and application of training systems, which emphasize result and experience based objectives, and are based upon educational principles to guide the education system.
 - (ii) Educational technology is the use of those audio-visual devices in training, which are based on modern technology, e.g., use of computer stimulators, television, radio, and video-tape.
 - (iii) It is self-training based on planned instructional material, through teaching machines.
- According to the Association for Educational Communication and Technology, AECT (1977), ‘educational technology is a complex and integrated process, involving people, procedures, ideas, devices and organization, for analysing problems and devising, implementing, evaluating and managing solutions to those problems, involved in all aspects of human learning’.
- According to Mitchell (1978), there are five fundamental definitions of educational technology:
 - (i) **Educational technology I (educational psycho technology):** This meaning depends upon psycho technology to enhance a learner’s capability by manipulating sensory input directly or indirectly. The various problems of educational psycho technology are: assessing the capability of students on the basis of diagnoses; clarifying the objectives of education; selecting or prescribing the instructions of communication, resources or actions and assessment. It includes all methods of management of the learning processes of others, in order to achieve certain prescribed behaviours. Controlled learning is important since student is the focal point. This meaning corresponds to the professional role of learning consultant.
 - (ii) **Educational technology II (educational information and communications technology):** This meaning stresses on the model, manufacture and assessment of training resources and communications for local or widespread distribution. Focus is on generating, selecting, processing and storage of information for the purpose of education and to retrieve information. This is to make knowledge more accessible. This meaning corresponds to the role of education materials provider.
 - (iii) **Educational technology III (educational management technology):** This definition stresses on organization of the resources of education. These resources include associated activities like planning, programming, budgeting, management, decision-making, operations research and system analysis. Organizational technology provides useful decision modes, information systems and organizational theory for man-

machine systems. This concept of educational technology is supported by both practical and theoretical investigations. So, this meaning corresponds to management of learning resources.

(iv) Educational technology IV (educational system technology): This concept pertains to functions like setting up, outlining, constructing and evaluating educational systems. The education system developer is concerned with administration, operations, extramural and alternative educational systems. It may envision and execute a computer-aided system of training or design suitable courses.

(v) Educational technology V (educational planning technology): This meaning focuses on planning at the supra-institutional or national level. Non-educators are the prime occupants of this field. Their belief in alternative opportunities of education is overshadowed by economic factors related to the role played by the educational planner.

This fivefold meaning of educational technology represents the primary and central concept of educational technology. Each of these types can stand alone and yet be integral to others.

Mitchell (1978) arrived at the following consolidated definition of educational technology: 'educational technology is an area of study and practice (within education) that is concerned with all aspects of the organization of educational systems and procedures, whereby resources are allocated to achieve specified and potentially replicable educational outcomes'.

According to the Scottish Council for Educational Technology (1979), 'educational technology is a systematic approach to designing and evaluating learning and teaching methods and methodologies, and to the application and exploitation of media and the current knowledge of communication techniques in education, both formal and informal'.

In the words of National Curriculum Framework, NCF (2006), 'educational technology could be defined in simple terms as the efficient organization of any learning system, adapting or adopting methods, processes and products, to serve identified educational goals'. This would involve:

- Systematic identification of the goals of education, taking into account nationwide needs (like higher scalability), system capabilities and learners' needs and potential
- Recognition of the diversity of learners' needs and the contexts in which learning will take place and the range of provisions needed for them
- Recognition of not only the immediate needs of children but also of their future needs in relation to the society for which we are preparing them
- Designing, providing for and enabling appropriate teaching-learning systems that could realize the identified goals
- Developing a range of support systems and training, enabling systemic conditions/materials and making them accessible schools
- Training teachers and students to use them

NOTES

NOTES

- Research existing and new techniques, strategies and technologies for solving problems of education, enabling judicious and appropriate application of technology
- Appreciation of the role of educational technology as an agent of change in the classroom, influencing the teacher and the teaching-learning process and its role in systemic issues like reach, equity and quality

In the executive summary of a paper on education technology, NCF (2006) opines: 'Educational technology is the efficient organization of any learning system, adapting or adopting methods, processes and products to serve identified educational goals. This involves systematic identification of the goals of education, recognition of diversity of learners' needs, the context in which learning will take place and the range of provisions needed for each of these'.

AECT has given its latest definition of educational technology as '...the study and ethical practice of facilitating learning and improving performance by creating, using and managing appropriate technological processes and resources' (Januszewski and Molenda, 2008). Mangal & Mangal (2010) opine: 'Educational technology should stand for a wise application of available human and non-human resources for providing appropriate solutions to educational problems and to improve the process and products of education'. Aziz Hap (2010) defines 'educational technology as 'the considered implementation of appropriate tools, techniques, or processes that facilitate the application of senses, memory and cognition to enhance teaching practices and improve learning outcomes'.

The wide differences in opinion, regarding the definition of educational technology among theorists and practitioners is very well revealed in the above definitions. These definitions initially embraced the whole range of activities of educational technology, from the methods of psychology of learning and teaching to audio-visual communication and mass technology.

However, one can list down certain characteristics of educational technology from the above definitions:

- It is concerned with the systematic application of science and technology in the field of education.
- It adds efficiency to the process of teaching-learning within formal and informal situations.
- It includes organization of appropriate learning conditions for realizing the goals of education.
- It stresses on developing methods and techniques for effective learning and evaluation.
- It encompasses the complete teaching and learning process and is not limited to specific aspects.
- It involves input, output and process aspects of education.
- It includes organization of learning conditions for realizing the goals of education.
- It enables and facilitates learning by control of learning situations, media and methods.

- It is not limited to the usage of audio-visual aids, but also extends to the application of psychological principles and instructional theories for improving the teaching-learning process
- It provides procedural and practical guidance and explanation to the glitches of education.

NOTES

CHECK YOUR PROGRESS

1. What is educational technology?
2. What does the meaning of educational planning technology focus on?

1.3 NATURE OF EDUCATIONAL TECHNOLOGY

The roots of educational technology lead us to the time when early tools had come to exist, e.g., paintings on cave walls. However, generally, its history begins with a film on education (1900s), or Sidney Pressey's mechanical teaching machines of the 1920s. Since then it has been evolving and taken many forms: PowerPoint presentations with voice-over; hypertext, i.e., V. Bush's memex in 1940s; Skinner's work led to 'programmed instruction' in 1950s; Computer Aided Instruction or Computer Assisted Instruction (CAI) in the 1970s, through the 1990s and in the present scenario it has taken the form of Computer Mediated Communication (CMC), e-tutoring and blended learning among others. However, educational technology should not be confused with teaching or instruction or learning or engineering, but it should be taken as sum total of all such aspects which go a long way in shaping the personality of the learner in a meaningful context (Singh, 2006).

Further, with changes in technology, the conception and nature of educational technology has also been adapting itself. Although the term has been in use for long now, however, it is still considered complex in nature. Educational technology is very versatile and comprises a cyclic procedure, a store of equipment (physical and conceptual) and a multiple-node liaison, mutually between learners and also between them and the facilitators of instructions (Hap, 2010). To understand the nature of educational technology, one needs to ascertain the objectives of educational technology and distinguish between 'technology in education' and 'technology of education'. One is also required to comprehend the components of educational technology.

Objectives of Educational Technology

As defined by Leith, educational technology is the application of scientific knowledge about learning and the conditions of learning to improve the effectiveness and efficiency of teaching and training. Educational technology has the following prime objectives:

- To modernize learning methods and techniques according to the changing world
- To bring desirable changes in the behaviour of teachers and pupils by improving teaching, learning and evaluation conditions

NOTES

- To make classroom teaching clear, effective, objective and scientific

Hilliard Jason has given the following points on the objectives of educational technology:

- It transmits information.
- It serves as a role model.
- It contributes to the provision of feedback.
- It assists in the practice of specific skills.

Alvin Toffler talks of 'responsible technology', so the objectives of educational technology can be as follows:

- To establish objectives and put together goals, in terms of behaviour
- To examine the learners' personality
- To structure the information in an order that is psychologically inclined
- To arbitrate between content and resources of presentation
- To assess the accomplishment of learners, in terms of the objectives of education
- To supply feedback, among other components, for modifying the learner

General objectives of educational technology

The general objectives of educational technology are:

- To identify educational needs of the community
- To determine the aims and objectives of education
- To prepare an appropriate curriculum
- To determine suitable strategies
- To identify human and non-human resources
- To identify problems which stand in the way of development of the learner's personality
- To suggest remedies to solve problems that emerge
- To manage the entire educational system
- To improve the process and product of education

Specific objectives of educational technology

The specific (from the viewpoint of specific classroom teaching) objectives of educational technology are:

- To identify the educational needs of the students
- To determine the classroom objectives in behavioural terms
- To evaluate and sort the content of instructions in logical or psychological succession
- To plan teaching methods and strategies of the presentation of content

- To make use of aid material, software and hardware, mass media and communication techniques
- To identify human and non-human resources
- To evaluate classroom teaching, in terms of performance of students
- To provide continuous feedback to students and the teacher for improving the teaching–learning process

NOTES

‘Technology in Education’ and ‘Technology of Education’

Education today has grown in leaps and bounds. Technology has made learning easier for both teachers and students. The developments in technology are not limited to gadgets and appliances used by people daily, but they have reached schools and classrooms. In this connection, there are two phrases which are popularly and often interchangeably used: ‘Technology in Education’ and ‘Technology of Education’. Though they sound similar, they are different.

‘Technology in education’ refers to the use of technological hardware in education. Here, more importance is given to the media used for carrying a message. It is mainly concerned with electrical and electronic gadgets, which are used to facilitate the teaching–learning process. This is a constantly evolving field that depends upon technological advancements. It involves the increasingly complex range of audio-visual equipment, hardware and sophisticated electronic devices like projectors, films, television, tape recorder, teaching machines, teletext and Computer Aided Instruction for individual and group learning. The use of technology in education has many advantages, just as technology has enriched every aspect of life. Technology in education is not limited to make learning and imparting of education easier in every possible way. It is also a field of study in itself for those who are involved with developing technological tools for educational purposes.

It is always advantageous to use technology in education because it helps both teachers and students to gain knowledge in a quicker and better way. Technology in education will be useful if it is properly planned and organized on psychological and pedagogical principles. Technology in education serves the following purposes:

- Supplies the needed appliances, equipment and mass media for accomplishment of different purposes and functions of education
- Facilitates training of the teachers to handle and make the finest use of equipment
- Develops a positive attitude among teachers and learners towards these appliances
- Signifies the relevance and use of the appliances in the context of individual and group learning, to achieve the goals of formal and informal learning

‘Technology of education’ can be referred to a purposeful utilization, in combination or separately, of objects, techniques, devices, events and relationships to increase the effectiveness of educational purpose. Technology of education deals with applying the resources of technological knowledge in an organized way, through

NOTES

which every individual has to pass, for acquiring and using knowledge. It governs the involvement of educationists in the design and evaluation of systems of learning, involving an understanding of the psychology of learning, communication and information theory. It signifies a technological approach to the system, issues and problems of education. This approach characterizes the methodology appropriate to learners' needs, learning objectives, the process of learning and teaching, as well as availability of resources. 'Technology of education' includes 'Technology in education', as shown in Figure 1.1.

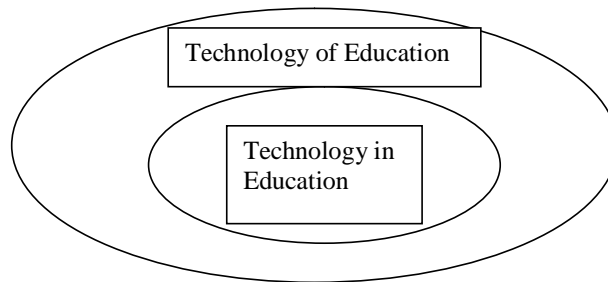

Fig. 1.1 'Technology in Education' as a sub-set of 'Technology of Education'

'Technology of education' also includes decisions about different aspects of education like determination of educational objectives to be achieved, the size of learning groups, learning sequence, teaching methods and selection of media. It also comprises the appropriate use of media, knowledge, ideas, human and non-human resources in systematic planning, designing, production, management and evaluation of the educational process. In other words, it includes the entire process of setting goals, continuous renewal of curriculum, trial and use of new methods and materials, evaluation of the system as a whole and resetting of goals in view of changing circumstances.

Saettler (1978) distinguishes between 'technology of education' and 'technology in education'. According to him, the former is a behavioural science conception, whereas the latter is a machine (device) conception of educational technology. Radio, television, OHP (overhead projector), computer, tape recorder, constitute 'technology in education'. On the other hand, programmes on radio and television, computer programmes and OHP transparencies that are based on scientific knowledge of education, constitute 'technology of education'.

Components of Educational Technology

S. P. Ruhela (2002) in his book, *Educational Technology*, has listed three main components of educational technology as a concept; and each component has a defined role to play in the process of education. The three components are:

- (i) **Methods:** Making use of a few devices like programmed learning, team teaching, micro-teaching and personalized system of instruction as methods in teaching-learning situations.
- (ii) **Materials:** Comprises instructional materials like programmed textbooks, manuals, guides, texts and other written/print materials.

- (iii) **Media:** Implies employing audio or visual or both audio-visual media, such as radio, tape recorders, charts, maps, posters, films and educational television as teaching aids to supplement effective teaching and promote better learning.

Besides, manpower is an essential component of educational technology, which intertwines the web of methods, materials and media. In view of this list of components of educational technology, the concept of educational technology needs to be understood in the broader perspective of education. It is a comprehensive technology associated with all aspects of the educative process such as choice of methods, teaching strategies, selection of adequate/relevant learning materials, use of appropriate aids and guiding in operation/handling of various equipment to ensure better performance on the part of the learner. AECT (1977) reports, 'educational technology is a broad concept encompassing teacher and learner, as well as the process and product of learning'. Educational technology functions as a mission with the prime concern of reaching a large section of the society through all possible means. Educational technology involves greater psychological and pedagogical preparedness, a scientific attitude and a coordinated approach to the educational process as whole. It reflects a professional interest and zeal for making experiments and innovations for the development and success of education.

NOTES

The highlights of the nature of educational technology are listed as:

- It is a science of techniques and methods which can help in realizing goals
- It is an application of the body of knowledge
- It takes help from the laws and findings of psychology, sociology, engineering, and some other basic social and physical sciences
- Its purpose is to improve teaching–learning situations
- It is a functional analysis of the teaching–learning process and it locates various components that operate from the stage of input to that of output.
- It is dynamic and progressive in nature
- It treats school as a system of well-laid inputs, processes and output components
- It does not subsume the role of a teacher
- It is not an end in itself but a means to accomplish some laid down goals
- It does not provide a solution to all types of problems, but it helps in the development of teaching and training processes of education
- It cannot be viewed in terms of its parts or processes; all branches, innovations, approaches and strategies should be integrated as a whole, according to the needs and requirements of the system represented by educational technology
- It is a technology that is continuously developing

In essence, one can say that educational technology is applied to the teaching–learning process with the main purpose of making the system efficient and effective. In other words, appropriate use of educational technology can make the teaching–learning process efficient and effective. However, practitioners need to be careful

NOTES

about the use of media, methods and materials. This has been explained in NCF (2006): 'The key phrases in ET (educational technology) are appropriate technology, that is, appropriate to the task in hand for meeting specific educational objectives and the organization of all available resources into a workable system, which is checked again and again to ensure that it is appropriate and changing it where it is not working. In applying the discipline of ET to the field of education, it is imperative that the media choice must relate to instructional design as well as to what is available and eminently usable'.

Further, educational technology should not be considered just as a subject but should be regarded as something that adds qualitative value, is relevant and appropriate. Its other attributes include transformation of education by making it dynamic and responsive and arousing curiosity and a desire to learn.

CHECK YOUR PROGRESS

3. List the objectives of educational technology as propounded by Hilliard Jason.
4. What does 'technology in education' refer to?

1.4 TYPES OF EDUCATIONAL TECHNOLOGY

Technology, media and materials that are useful in the instructional process, comprise simple varieties that help teachers to develop and present their lessons more effectively in traditional classrooms. They also comprise sophisticated machines and mechanisms that completely change the structure and scenario of classroom teaching. A number of technological media and materials can be useful in both teaching and in the management of administrative data that is necessary in modern mass education. Educational technology can thus assume many forms. Often, its only aim is to make the current practices more efficient and effective. However, at times educational technology brings about pedagogical alterations. Though it can be regarded as a design science, it also tackles the basic problems related to learning, teaching and social organization. Hence, the complete use of all features of modern social science and life science methodology are captured by it. Educational technology performs the twin functions of a tool and a catalyst. The three commonly accepted types of educational technologies are: (i) teaching technology, (ii) behavioural technology and (iii) instructional technology. These are discussed below.

1.4.1 Teaching Technology

Teaching is a skill. The use of technology in teaching makes this skill simpler, specific, functional and unprejudiced. This form of educational technology rests itself on the knowledge of philosophy, psychology and science, so as to achieve the desired learning objectives. There are two important features of teaching: (i) content and (ii) classroom communication. Substance and interaction are the two factors that form teaching technology. In addition, contemporary teaching focuses on the student and not on

the teacher. Thus, it needs a psychological analysis of the learner. Hence, teaching is both scientific and psychological. The system of learning assists the teacher in making right decisions. In addition, it also builds up a sense of professionalism that makes one accountable. It incorporates essential alterations in the idea of teaching; teacher's training, formulating the policies of teaching, and management objectives of a teacher. Teaching technology is that form of educational technology, which is concerned with making the process of teaching more systematic.

NOTES

Assumptions of teaching technology

Teaching technology is based on the following assumptions:

- Nature of teaching process is scientific
- Teaching activities can be modified as required
- Pre-determined learning objectives can be achieved through teaching activities.
- A mutual relationship between teaching and learning can be established.
- Proper conditions can be created for effective learning.

Characteristics of teaching technology

E. G. Vedanayagam (1988) has solicited a list of characteristics and fundamental principles of teaching technology. These are as follows:

- Teaching is a scientific process and its major components are content, communication and feedback.
- There is a close relationship between teaching and learning.
- It is possible to modify, improve and develop teaching–learning activities.
- The terminal behaviour of the learner, in terms of learning structures, can be established by appropriate teaching environment.
- Teaching skills can be developed and strengthened by means of feedback devices, with or without sophisticated techniques.
- Pre-determined learning objectives can be achieved by designing suitable teaching activities.
- The use of achievement motivation technique enhances the output of a teacher and a learner.

Technology is a rapidly changing area of the curriculum. For experienced teachers as well as students and novices, technology has evolved the need for a whole new range of knowledge and skills in teaching. Davies (1971), in his book, *Management of Learning*, has presented the contents of teaching technology in four steps— (i) planning of teaching, (ii) organization of teaching, (iii) leading by teaching and (iv) control of teaching. These are discussed in detail, as follows:

- **Planning of teaching:** Within this phase, the teacher examines the subject matter, decides upon and describes the learning objectives, and puts these objectives clearly in writing. The following three activities are performed by him, as part of this phase: (a) task analysis, and (b) identification of the aim of teaching, (c) noting down learning objectives. As quoted by I.K. Davies, 'in teaching, planning is the work a teacher does to establish learning objectives'.

NOTES

- **Organization of teaching:** In this stage, an effectual atmosphere is created by the teacher. This is done through the selection of teaching techniques, approaches, procedures and vital benefits.
- **Leading by teaching:** In this stage, the teacher is a source of motivation for the students. They show interest in the teaching and learning objectives in every phase of this stage. I. K. Davies wrote, ‘leading is the work a teacher does to motivate, encourage and inspire students, so that they readily achieve the objectives of learning’.
- **Control of teaching:** In this stage, there is no change in prearranged and described purpose of learning. This stage does not comprise the introduction of any change. However, the prospect is reviewed by the teacher, so that the predefined goals can be achieved. For accomplishing this impressive task, support is sought by the teacher through different techniques of validation and measuring of dimensions. If the teacher comes to the conclusion that the learning objectives have not been accomplished, then it is his duty to bring essential modifications in the organization’s behaviour.

1.4.2 Behavioural Technology

Behavioural technology is a vital constituent of educational technology. It emphasizes that psychosomatic values be used in learning and teaching. The motive is to change the behaviour of the teachers and pupils to match with the objectives of teaching. This form of educational technology is dependent on psychology. Behaviour is the focus of the process of education and learning with their objective to bring persistent changes. Different learning experiences are shared with learners to bring desirable changes in their behaviours. Here, behaviour would mean the cognitive, conative and affective activities of an individual. Behaviour technology, as a form of educational technology, is utilized to study and bring modification in the behaviour of all learning organisms. B. F. Skinner popularized the usage of this term while making use of his ‘theory of operant conditioning’. He used the theory to bring desired modifications in the behaviour of learning organisms. In the area of learning and education, behavioural technology focuses on the behaviour of teachers. Hence, it is sometimes also referred to as ‘training psychology’. In schools, the task of behavioural technology has become almost synonymous with behaviour analysis and behaviour modification, carried out through the principles of operant conditioning and observation learning. In other words, behavioural technology focuses attention on the use of principles that have a psychological orientation in the processes of learning and teaching. This works to alter the behaviour of the teachers and pupils to match it with the mode of teaching. Behavioural technology is aimed at boosting the growth and development of behaviour and learning. It employs the following to transform the behaviour of a teacher:

- Definition of teacher-behaviour
- Doctrines of teacher-behaviour
- Observation technique of teacher-behaviour
- Study and nature of teacher-behaviour

- Assessment and standards of teacher-behaviour
- Prototypes of teacher-behaviour
- Different tools to develop teacher-behaviour such as: programmed instructions, T-group training, interaction analysis techniques and simulated training of social skills

NOTES

Suppositions of behavioural technology

Behavioural technology is based on the following suppositions:

- A teacher's behaviour socially and psychologically.
- A teacher's behaviour can be observed.
- A teacher's behaviour can be measured.
- A teacher's behaviour can be modified.
- Everyone is not a born teacher.
- Teachers can also be made.

Salient features of behavioural technology

Some of the important characteristics of behavioural technology are:

- The basic function of behavioural technology is psychology.
- Strength and responses are strongly focused upon in behavioural technology.
- The teaching acts are appraised from a purposeful viewpoint in behavioural technology.
- Behavioural technology emphasizes psychomotor goals.
- Behavioural technology is in terms of the software approach.
- Behavioural technology is widely practised in training institutes of teachers.
- The attention of behavioural technology can be based on individual differences between students and teachers.
- Behavioural technology is focused on the elements and direction of behaviour in a classroom.

Behavioural technology would help practitioners to know the nature of the existing behaviour, the nature of the target behaviour, and the ways and the means to meet gaps between existing and target behaviours.

1.4.3 Instructional Technology

The evolution of a technology occurs when scientific learning and communication are used in teaching. When physical sciences interact with education, we are provided with traditional support, gear, materials like paper, ink, books, radios, films, televisions and more refined progressive hardware like, computers, space satellites, and language laboratories. Stoluraw (1963) stressed on the theory of existence of three most important factors that are focused on the association of instruction and technology: (i) the population explosion in the world, (ii) the exponential pace of the spread of new knowledge, and (iii) scientific and technological changes in our present social

NOTES

structure. Robert A. Cox defined the technology of instructions as ‘... the application of scientific process to man’s learning conditions’. E. E. Haden opined, ‘instructional technology is that branch of educational theory and practice, concerned primarily with design and use of messages which control the learning process’. The definition given by Unwin (1969) described instructional technology as: ‘The application of modern skills and techniques to requirements of education and training (instruction). This includes the facilitation of learning by manipulation of media and methods and the control of environment’.

Another popular and accepted definition has been given by S. M. McMurrin (1970): ‘**Instructional technology** is a systematic way of designing, carrying out and evaluating the total process of learning and teaching, in terms of specific objectives based on research, human learning and communication. It employs a combination of human and non-human resources to bring about the more effective instruction’. AECT has defined instructional technology as, ‘the theory and practice of design, development, utilization, management and evaluation of processes and resources for learning’.

In the present scenario, instructional technology is broadly necessitated to establish a progress in teaching, in learning and in the process of evaluation. This form of educational technology is meant for helping the instructor and the learner in the desired instructional task for the realization of stipulated instructional objectives, in a particular teaching–learning situation (Mangal, 2010). In other words, focus is on developing the instruction process.

Assumptions of instructional technology

The fundamental assumptions of instructional technology are as follows:

- A student is able to learn in accordance with his requirement and capability.
- A student can learn even if the teacher is not present.
- One can augment a particular instruction by its continuous use.
- Instructional objectives can be achieved with the help of learning objectives.
- The area of discussion can be segregated into different sectors or parts, and every part can be taught in an independent way by use of this technology.

Unique features of instructional technology

Following are the characteristics of instructional technology:

- Instructional technology helps a lot in the achievement of reasonable goals.
- Instructional technology can make teachers more efficient.
- When supported by instructional technology, the students can learn in accordance with their requirement and speed of grasping.
- Instructional technology has control over individual disparities.
- Instructional technology also uses the theory of conditioned response.
- A more detailed examination of subject matter is carried out with the help of instructional technology, which motivates optimism, pertaining to the remarkable manner in which the contents are presented.

Instructional technology suggests many tools, techniques and knowledge which are used in designing and delivering results. Together they provide useful means towards accomplishing educational objectives. It is important to know and be responsive to:

- The destination of delivery of instructions
- The tools and techniques available to deliver instruction
- The right time to use these tools
- Design and delivery of successful learning experiences
- Proper distribution of content and methods
- The best place to deliver instruction
- Ensured meeting of expectations
- Revision techniques, in case instructions are not met

The field of instructional technology will only grow if technology improves. The use of technology will help the delivery of education in an efficient manner, by overcoming the limitations and problems faced by the education sector. This form of educational technology is gaining popularity because instructional technologists claim to achieve effective learning by investing less time and cost, than through other means.

The main points of difference between three types of educational technologies (behavioural technology, teaching technology and instructional technology) are listed in Table 1.1.

Table 1.1 Comparison of Three Types of Educational Technologies

Aspect	Teaching Technology	Behavioural Technology	Instructional Technology
Exponents	I. K. Davis, Hunt, Morrison, Herbart	B. F. Skinner, Flander, Ober, Amidon	Lumsdan, Bruner, Asubel, Glaser
Purpose	Development of cognitive, affective and psychomotor domains	Development of cognitive, affective and psychomotor domains	Development of cognitive domain
Base	Philosophy, psychology and science	Psychology	Psychology and science
Approach	Hardware and Software	Software	Hardware
Focus	Teaching	Teacher	Instruction
Application	For making classroom teaching purposeful and effective	For producing effective teachers	Self-study, correspondence, remedial study

NOTES

NOTES

CHECK YOUR PROGRESS

5. Name the three types of educational technologies.
6. What is behavioural technology?

1.5 COMPONENTS OF EDUCATIONAL TECHNOLOGY: HARDWARE AND SOFTWARE

Professor Henry Ellington (1993) opined that the key function of educational technology is to bring about improvements in the general competence and efficacy of the teaching–learning process. He further said that these improvements can be introduced in the following ways:

- By enhancing the quality and capacity of learning
- By reduction of the turnaround time for learners to achieve the assigned objectives
- By making teachers more efficient
- By cost-cutting without compromising on quality
- By making learners capable of taking their own decisions
- By providing education in more flexible ways

Considering educational technology as multifaceted in nature, Lumsdaine (1964) has listed its three distinct approaches:

- (i) Educational technology I (ET1) or the hardware approach
- (ii) Educational technology II (ET2) or the software approach
- (iii) Educational technology III (ET3) or the systems approach

1.5.1 Hardware Approach

The hardware approach implies the use of mechanical materials and equipment in the domain of education. Audio-visual aids like charts, models, filmstrips, slides, audio cassettes and sophisticated equipment and gadgets like films, projectors, radio, tape recorder, record player, television, video, teaching machines, computers, etc., fall in the category of hardware. The hardware approach is based on the application of principles of physical sciences and engineering to education and training. In this system, the teaching process is being mechanized gradually so that maximum pupils may be educated in minimum time and at low costs. This approach is a by-product of the scientific and technological developments of the 20th century.

It is to be noted that teaching machines are the only mechanical aids deliberately designed and invented to fulfil instructional requirements. All other audio-visual aids were designed and manufactured for improving the communication system, but now they are being used for instructional purposes.

The mechanization is being introduced for preservation, transmission and advancement of human knowledge. For instance, a teacher can deal with a large group of students by his discourse on radio or television. Thus, educational and training systems are able to deal with an increased number of students and the cost per student has been reduced by the hardware approach to education. Silverman (1968) referred to this type of educational technology as 'relative technology'. This comprises borrowing and applying technology, machines and devices in the process of teaching and learning. In this context, educational technology serves a simple 'service' function in education.

Ivor Davies calls this approach the '*Audio-visual Archetype*'. This approach stresses on the employment of machines, devices, equipment and similar instructional aids. This approach focuses on the teacher and his/her teachings. 'Technology is seen as a means of mechanizing or automating the process of teaching with devices that transmit, amplify, distribute, record and reproduce stimuli materials and thus increase the teacher's impact, as well as widen potential audience' (Davies, 1978). In the beginning, media had developed this approach during the 1930s. It gained prominence during the post World War II period. According to Davies, this 'audio-visual archetype' considers audio-visual hardware to perform functions like supporting classroom presentations, improving demonstrations by giving access to reality or simulations of reality. It is not possible for a teacher to come up with these, within a short span of time. Nevertheless, this approach has faced several criticisms for the lack of coordination in its application.

NOTES

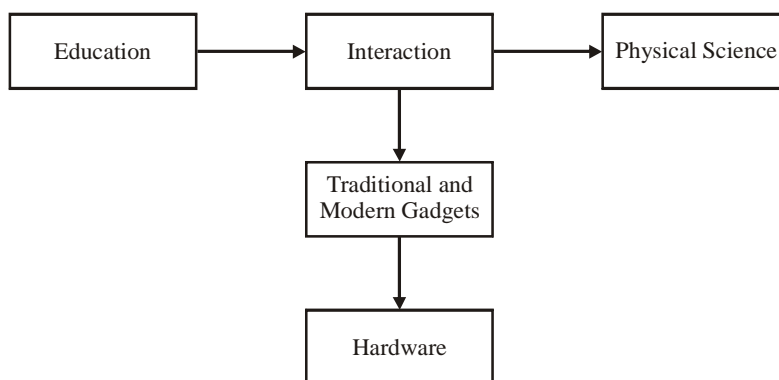

Fig. 1.2 The Hardware Approach

Characteristics of hardware are as follows:

- Hardware components are generally electronic and mostly depend on mechanical systems.
- New techniques and researches are being conducted to evaluate the effect of hardware.
- The outcome of hardware is direct and immediate because of its concrete form.
- Hardware components are the media of communication.

1.5.2 Software Approach

NOTES

The software approach or software technology of education owes its origin to behavioural sciences and their applied aspects concerned with the psychology of learning. It originated from the engineering efforts of Skinner and other behaviourists. According to Arthur Melton (1959), software teaching is directly related to psychology of learning, which comprises behavioural changes resulting from experience. This view of educational technology is associated with modern principles and theory of teaching, models of teaching, theory of instruction, and theory of teacher-behaviour and principles of programmed learning. The components of software technology are closely associated with the modern principles of programmed learning, such as:

- Task analysis
- Writing objectives in behavioural terms
- Selection of appropriate instructional strategies
- Reinforcement of correct responses
- Constant evaluation

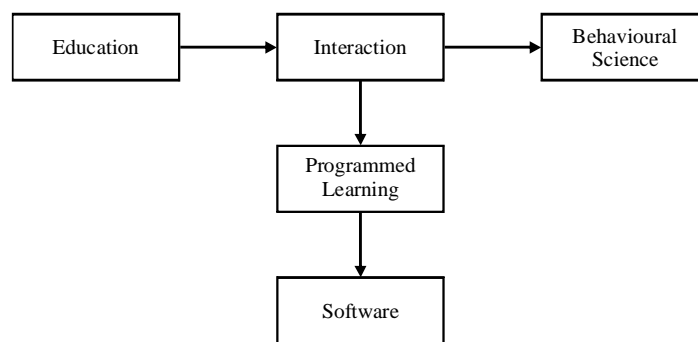

Fig. 1.3 The Software Approach

Leith observed that, 'educational technology is the application of scientific knowledge about learning and the conditions of learning to improve the effectiveness and efficiency of teaching and learning'. Silverman (1968) termed software technology as constructive educational technology due to its constructive nature. Its basic educational applications are in the analysis of instructional problems, selection or construction of measuring instruments required to evaluate instructional outcomes and construction or selection of strategies and tactics to produce desired educational outcome.

Ivor Davies, names this approach as the '*Engineering Archetype*', which applies the principles of behavioural science for the betterment of learning. Despite the use of hardware, this approach focuses on the learner and the learning. Therefore, it is called the software approach. 'Technology is seen as a means of providing the necessary know-how for designing the new, or renewing the current, worthwhile learning experiences. Machines and mechanization are merely viewed as instruments of presentation or transmission' (Davies, 1978).

It was in early 1969 that software approach initially developed in the area of programmed learning. It was the outcome of Skinner's efforts on operant conditioning.

In the beginning, this approach found its application in the design of materials having sequential content. Soon after, it was widely used as part of curriculum and for developing courses. Based on the engineering approach, it takes the form of a series of steps to be followed. These steps comprise a statement of inputs and definition of objectives, intermediate steps which examine and select instructional strategies and resources and a terminal step of evaluation and output. This process always includes feedback. Though conventionally, ET1 went aboard after ET2, it is not to be regarded as a successful version of ET1. The development of both versions was independent and they still exist.

NOTES

Table 1.2 Differences between Hardware and Software Approaches

Hardware approach	Software approach
Hardware approach has its origin in physical science and applied engineering.	The origin of software approach is in behavioural science and its allied aspects concerning the psychology of learning.
It refers to the application of the principles of physical sciences or engineering and technology, in the development of electro-mechanical equipment used for instructional purposes.	It refers to the application of teaching-learning principles to direct and deliberate shaping of behaviour.
It tries to adopt a product-oriented approach.	It tries to adopt a process-oriented approach.
It helps in better communication of educational purposes. It makes teaching effective by mechanizing the teaching-learning process. It increases the efficiency of educational means and reduces the cost of education.	It contributes to increase the efficiency of teachers as well as learners. However, it lags behind in reducing the cost of education.
It comprises charts, models, slides, filmstrips, audio cassettes, sophisticated equipment, gadgets like television, film projectors, tape recorders, record players, videos, teaching machines and computers.	It comprises modern principles and theory of teaching, models of teaching, theory of instruction, theory of teacher behaviour and principles of programmed learning.
Hardware technology is concerned with production and utilization of audio-visual aid material, sophisticated instruments and mass media for helping teachers and learners to achieve better results.	Software technology, tries to exploit the psychology of learning for production and utilization of software techniques and material in terms of learning material, teaching-learning strategies, tools of evaluation and other devices.
Hardware is of no use without a suitable software that governs its working. It needs the services of software technology for its functioning.	Software approach makes the hardware functional.
Hardware is prepared by assembling different gadgets. The same hardware can be used in different fields like industry, entertainment, education, corporate sector.	Silverman termed educational technology as 'constructive educational technology'. It concentrates on the analysis, selection and construction of whatever is necessary to meet only educational requirements.

NOTES

Thus, we may conclude that while the hardware approach originated from physical sciences and applied engineering, the software approach owes its inception to behavioural sciences and their applied aspects concerned with the psychology of learning.

Significance of software and hardware

The significance of software and hardware in education are as follows:

- They cater to individual differences of students
- They contribute to the economy of time, energy and resources of teachers and students
- They bring clarity and vividness to the subject matter
- They help to motivate students
- They help in developing and sustaining the interest of the students
- They make the subject matter interesting, attractive, inspirational and effective
- They provide for active participation of students

These aspects of educational technology are closely intertwined to serve the cause of education. Hence, a clear demarcation between their constituents is difficult. For every hardware, there is a corresponding software, as shown in Table 1.2.

Table 1.3 Educational Hardware and Corresponding Software

<i>Hardware</i>	<i>Software</i>
Overhead projector (OHP)	Overhead transparencies
Slide projector	Slides
VCR and monitor	Video programmes
Computer	Computer programmes
Blank paper	Written matter

It needs to be clarified here that Table 1.2 is not an exhaustive list, but only a suggestive list of components. The list is endless and continuously growing owing to the rapid technological developments taking place and even faster adoption of these newer technologies in teaching–learning situations. What needs to be borne in mind is that with the development of new technologies, the older ones still occupy an important place in our educational system.

CHECK YOUR PROGRESS

7. What are the equipment and gadgets that fall under the category of hardware?
8. List the characteristics of hardware.

1.6 SYSTEMS APPROACH IN EDUCATIONAL TECHNOLOGY

Systems analysis or approach is a term used to describe the systematic application of educational technology to an educational or training problem starting with the input (entry behaviour) and output (terminal behaviour) and determining how best to progress from the former to the latter. Systems approach is an educational tool developed to make the educational adventure more flexible, holistic, logical, orderly, responsible and self-correcting rather than intuitive, undefinable and unordered. What is unique about the systems approach is that it enables the analysis of not isolated components, but of the whole and helps one to think in a Gestalt way rather in a fragmented manner. Aristotle's statement, 'the whole is more than the sum of its parts' indicates the basic nature of a system.

Definition of systems analysis

- *The Advanced Learner's Dictionary of Current English* defines a system as 'Group of things or parts working together in a regular relation.'
- A. K. Jalaluddin (1981): 'A system may be defined as a dynamic, complex, integrated whole consisting of self-regulating pattern of interrelated and interdependent elements organised to achieve the pre-determined and specified objectives.'
- A. Angyal in *Foundations for a Science of Personality* (1941) defined systems approach as a holistic organization, where parts of the system are arranged (organized and interrelated) in a way that distinguishes them from a simple collection of objects.
- *Banghart* (1969) defines a system as 'an integrated assembly of interacting elements, designed to carry out co-operatively a predetermined function.'

All systems are made of parts called the sub-systems and are parts of the higher order system called the supra-system. A simple system is illustrated in Figure 1.4. In the figure, the system consists of four distinct elements or components, A, B, C and D, which are related to or dependent upon one another as indicated. Some inter-relationships may be two-way, while others may be one-way only.

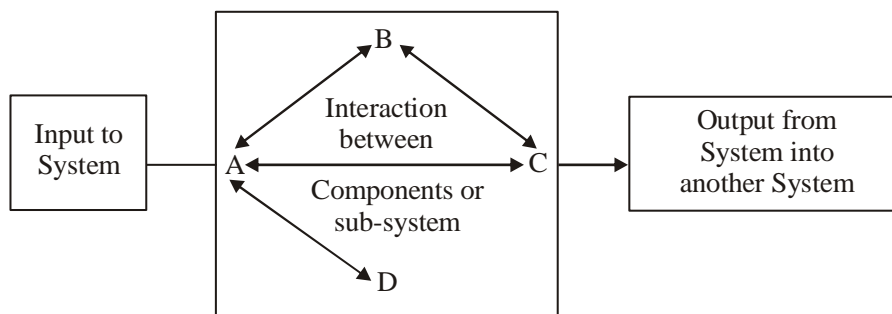

Fig. 1.4 Typical system

NOTES

1.6.1 Systems Approach in Education

NOTES

Education is a dynamic system, its efficiency being determined by the inputs and the outputs. It is a dynamic organization of mutually related components in a meaningful pattern and any change in one component may affect the overall performance of the system, either beneficially or adversely.

Systems approach as applied to education is a rational problem solving method of analysing the educational process taken as a whole, incorporating all of its parts and aspects, including the students and teachers, the curriculum content, the instructional materials, the instructional strategy, the physical environment and the evaluation of instructional objectives.

Vandana Mehra in an article gives the systems model of the process of education as given in Figure 1.5. As is evident from the figure, input to an educational system consists of people, resources and information and the output consists of people whose performance has improved in some desired way. The output is improved through increasing the efficiency of educational process for enabling optimum assimilation of knowledge and skills to occur during the educational process and hence, maximize the quality of the output.

Components of an instructional system are:

- Stating instructional objectives which helps system designer to decide what to teach
- Pupils
- Teachers
- Content
- Determining optimum learning conditions to attain instructional objectives i.e. task analysis, keeping in mind the entry behaviour of learners.
- Deciding upon the instructional strategy and media
- Conducting evaluation (formative and summative and feedback)

Figures 1.6, 1.7 and 1.8 explain various aspects of the instructional system.

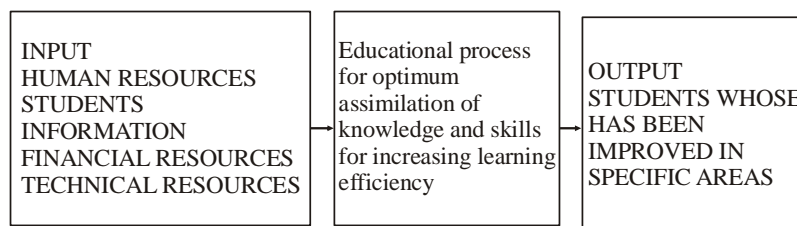

Fig. 1.5 The 'System' Model of the Educational Process

Processes involved in systems approach. Following processes are involved in the systems approach:

- Identifying objectives
- Designing learning experiences
- Evaluating effectiveness in achieving the objectives
- Improving learning experiences in the light of evaluation to better the objectives

NOTES

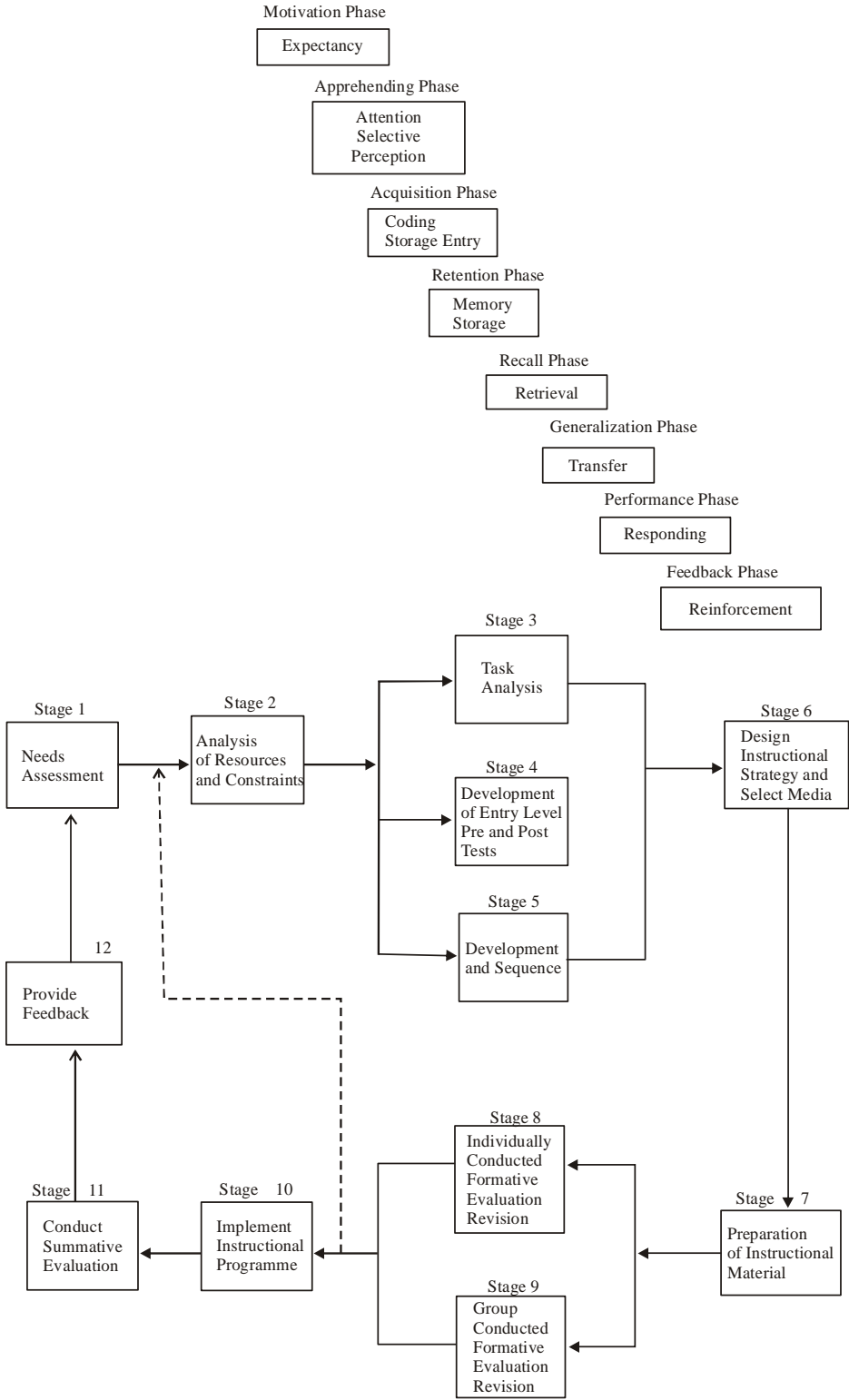

Fig. 1.6 Model of the Instructional System

NOTES

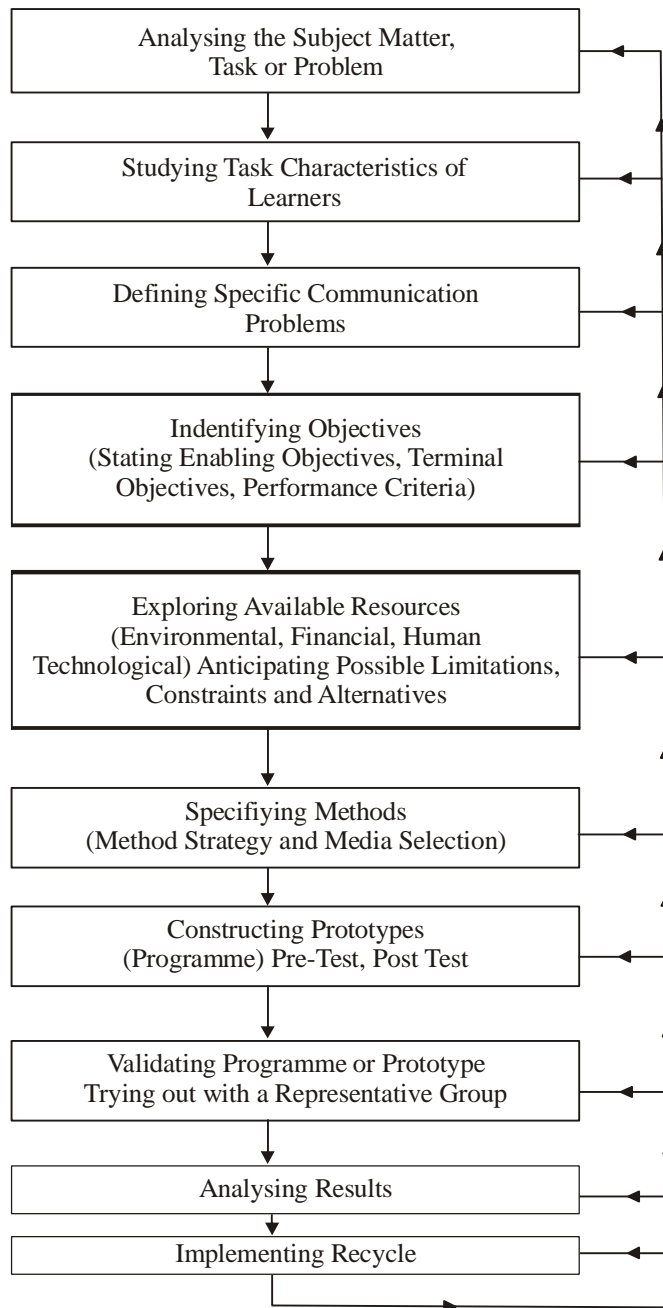

Fig. 1.7 Flowchart Showing in Detail the path Followed at the Macro-Level—Instructional level in Designing a System

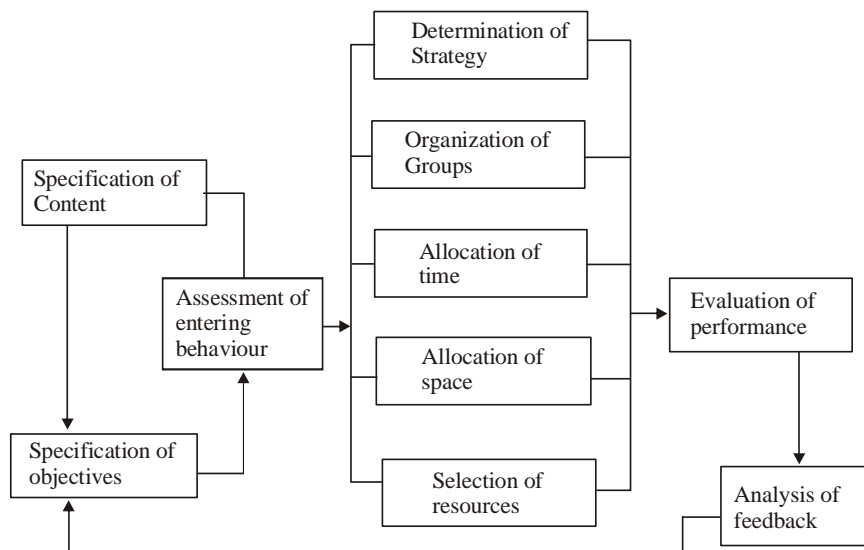

Fig. 1.8 Systematic Approach to Instruction (as developed by Vernon S. Gerlach and Donald P. Ely in *Teaching and Media: A systematic approach*)

NOTES

Steps in systems approach

I. *Identifying objectives*: This step includes:

- Determining the broad aims of the course
- Deciding as to what kind of people you are helping your students to become
- Finding out the range of backgrounds, interests, attitudes, aptitudes, skills and understandings of the students
- Deciding learning experiences that the learners should process
- Deciding about the test you will use as a criterion for evaluation when checking the extent to which objectives have been achieved
- Deciding about the various techniques you would use, i.e., paper-pencil test, interviews, observation, and questionnaire

II. *Designing learning experiences*: This includes:

- Visualising conditions necessary to achieve these objectives
- Identifying learning sequences
- Deciding teaching strategy for reaching the goal
- Selection media of teaching-learning, i.e., lecturing, discussion, field trips, role playing, textbook, models, programmed learning, and multimedia
- Documenting experiences which include film also

III. *Evaluating effectiveness in achieving the objectives*: This implies:

- Engaging students in the learning experiences you have designed
- Applying criterion tests to determine how students have changed as a result
- Determining which objectives have been most widely attained, which remain unattained and by which set of students

- It assists in making use of technological advance to provide integration of machines, media and people for attaining the defined goals.
- It permits an orderly introduction of components required to be demonstrated for systems' success in terms of student learning.
- It avoids rigidity in plan of action as continuous evaluation affords desired changes to be made.

NOTES

1.6.3 Role of the Teacher in Systems Approach

As a matter of fact, best teachers have always done something of the sort of systems approach. It has, therefore, been stated by Michael Eraut and Geoffrey Squires that systems approach is a 'response different in degree rather than kind from the other good method'.

A system-oriented teacher does the following:

- Thoroughly assesses the inputs of his system
- Gathers as much data as possible about his subject-matter
- Thinks of alternative processes for achieving his objectives
- Analyses his objectives into well-defined learning tasks
- Conducts discussions regarding processes and components based on the best means of furthering the purposes
- Activates the system by putting the plan into action
- Gathers feedback data accordingly and systematically
- Modifies the system's components and processes based on the feedback
- Assesses the effectiveness of the system by comparing the outputs with the inputs
- Modifies the system based on all resources of feedback

CHECK YOUR PROGRESS

9. Define systems analysis.
10. How is the systems approach applied in the field of education?

1.7 MULTIMEDIA APPROACH IN EDUCATIONAL TECHNOLOGY

Among the most significant forces for change in recent years is the technological sophistication we now possess, for this sophistication not only affects our lives in profound ways but also seems to hold a tantalizing promise for increasing our efficiency in education (Kinder, 1973). The last 80 years have seen the development of steam-driven, high-speed rotary presses, advanced optics, films, wire and tape sound recordings, simple and complex duplicating and copy machines, radio, television, computers, and communication lasers.

NOTES

This technological escalation has bestowed upon education proliferation of equipment and materials which can assist in the reorganization and redefinition of educational experiences. In the past, most teaching depended almost entirely on verbal communication between teacher and student, or written communication to the student from printed materials. Although, these communication channels continue to play important roles in the learning process, today's students are learning facts, skills and attitudes from pictures, television, recorded words, programmed lessons, and other media. Once technology enters the school building, dramatic renovations usually begin. With the technological magic touch, a simple school-house turns into a systematized learning centre.

Today, many countries around the world use some form of technological media in education. In a few countries, the use is fairly widespread. Most technological devices and programmes, however, are structured around the needs of the teacher and are employed as teaching aids in the classroom. In other words, most educators are using technology to answer the question: how can technology help the teacher? In a few areas, however, focus is on the needs of the student. There, educators ask the question: how can technology help the learner?

In the instances, where the student is the centre of attention, technology is the catalyst for educational change. Its absence would make a significant difference to the educational process, because technology is an integral part of a well-thought out system, not merely a teacher's aid. 'Audio-Visual Aids', 'Educational Communication Technology', 'Audio-Visual Media', 'Learning Resources' and 'Instructional or Educational Media'. All these terms mean the same thing. Earlier the term used was audio-visual aids in education. With the advancement in the means of communication and that of technology, educators coined new terms. More specifically media refers to films, filmstrips and recordings. The use of newer terms Educational Technology or Instructional Technology is primarily due to the dynamic expansion of programmed learning, computer assisted instruction and educational TV. This revolution in the field of audio-visual education is the outcome of the development in electronics, notably those involving the radio, tape recorder and computer.

The replacement of the older and perhaps more familiar term 'audio-visual material' in education by the new term educational technology or instructional technology is primarily due to the dynamic use and expansion of TV and other existing new developments in the field of audio-visual education that promise much more for the future.

Locatis and Atkinson (1984) define media as the means (usually audio-visual or electronic) for transmitting or delivering messages. Multimedia includes such things as prints, graphics, photography, audio-communication, television, simulating games and computer.

Schramm, Wilber (1973) in his book *Big Media—Little Media, Aid Studies in Educational Technology*, categories computer, VCR, TV as 'big media' and 'radio, filmstrips, graphic, audio cassettes and various visuals as 'little media'.

1.7.1 Audio-Visual Aids

Dutch humanist, theologian and writer Desiderius Erasmus (1466-1536) discouraged memorization as a technique of learning and advocated that children should learn through the aid of pictures or other visuals. John Amos Comenius (1592-1670) prepared a book known as *Orbis Sensualium Pictus*, (The World of Sense Objects) which contained about 150 pictures on aspects of everyday life. The book is considered to be the first illustrated textbook for childhood education. This book gained wide publicity and was used in childhood education centres all over the world. Jean Jacques Rousseau (1712-1778) and other educators stressed the need of pictures and other play materials. Rousseau condemned the use of words by teachers and he stressed 'things'. He pleaded that the teaching process must be directed to the learner's natural curiosity. Pestalozzi (1756-1827) put Rousseau's theory into action in his 'object method'. He based instruction on sense perception. The term 'visual education' was used as early as 1926 by Nelson I. Greene.

Eric Ashby (1967) identified four revolutions in education: education from home to school, written word as tool of education, invention of printing and use of books and lastly the fourth revolution in the use of electronic media i.e., radio, television, tape recorder and computer in education.

Definition of audio-visual aids

Some of the definitions of audio-visual aids are:

- **Burton:** Audio-visual aids are those sensory objects or images which initiate or stimulate and reinforce learning.
- **Carter V. Good:** Audio-visual aids are those aids which help in completing the triangular process of learning i.e., motivation, classification and stimulation.
- **Edgar Dale:** Audio-visual are those devices which facilitate the communication of ideas between persons and groups in various teaching and training situations. These are also termed as multi-sensory materials.
- **Good's Dictionary of Education:** Audio-visual aids are anything by means of which learning process may be encouraged or carried on through the sense of hearing or sense of sight.
- **Kinder, S. James:** Audio-visual aids are the devices which can be used to make the learning experience more concrete, more realistic and more dynamic.
- **Mckown and Roberts:** Audio-visual aids are supplementary devices by which the teacher, through the utilization of more than one sensory channels is able to clarify, establish and correlate concepts, interpretations and appreciations.

Meaning, significance and advantages of audio-visual aids

Audio-visual aids or devices or technological media or learning devices are additional devices that help the teacher to clarify, establish, co-relate and co-ordinate accurate concepts, interpretations and appreciations and enable him to make learning more concrete, effective, interesting, inspirational, meaningful and vivid. They help in

NOTES

NOTES

completing the triangular process of learning viz., motivation, clarification and stimulation. The aim of teaching with technological media is 'clearing the channel between the learner and the things that are worth learning'. The basic assumption underlying audio-visual aids is that learning—clear understanding—stems from the sense experience. The teacher must 'show' as well as 'tell'. Audio-visual aids provide significant gains in informational learning, retention and recall, thinking and reasoning, activity, interest, imagination, better assimilation and personal growth and development. The aids are the stimuli for learning 'why', 'how.', 'when' and 'where'. The 'hard to understand principles' are usually made clear by the intelligent use of skilfully designed instructional aids.

According to Gandhi, 'True education of the intellect can only come through a proper exercise and training of bodily organs— hands, feet, eyes, ears and nose.'

Commenting on the use of audio-visual aids, the Kothari Commission 1964-66 observed that it should indeed bring about an 'educational revolution' in the country. It further stated that the supply of teaching aids to every school was essential for the improvement of the quality of teaching.

The National Policy on Education, 1986, and as modified in 1992 has laid a great stress on the use of teaching aids, especially improvised aids, to make teaching-learning more effective and realistic.

In the words of Edgar Dale, 'Since audio-visual materials supply concrete basis for conceptual thinking, they give rise to meaningful concepts enriched by meaningful association, hence they offer the best antidote for the disease of verbalism.'

Some of the important values of the proper use of audio-visual aids are given below:

- **Best motivators:** They are the best motivators. The students work with more interest and zeal. They are more attentive.
- **Antidote to the disease of verbal instruction:** They help to reduce verbalism. They help in giving clear concepts and thus help to bring accuracy in learning. As observed by Raymond Wyman (1957), 'We (teacher) tell students, and we provide them with written material most of the time. Words are wonderful. They are easily produced, reproduced, stored and transported. However, the overuse or excessive use of words can result in serious problem, chiefly, the problem of verbalism (using or adopting words or phrases without considering what they mean) and forgetting.'
- **Clear images:** Clear images are formed when we see, hear, touch, taste and smell as our experiences are direct, concrete and more or less permanent. Learning through the senses becomes the most natural and consequently the easiest.
- **Vicarious experience:** It is beyond doubt that the first-hand experience is the best type of educative experience. But it is neither practicable nor desirable to provide such experience to pupils.

Substituted experiences may be provided under such conditions. There are many inaccessible objects and phenomena. For example, it is not possible for the pupils living in India to see the eskimos. Similarly, it is not possible for an average man to climb the Mount Everest. There are innumerable such things to which it is not possible to have direct access. So, in all such cases, these aids help us.

NOTES

- **Variety:** Mere 'chalk and talk' do not help. Audio-visual aids give variety and provide different tools in the hands of the teacher.
- **Freedom:** When audio-visual aids are employed, there is great scope for children to move about, talk, laugh and comment upon. In such an atmosphere the students work because they want to work and not because the teacher wants them to work.
- **Opportunities to handle and manipulate:** Many visual aids offer opportunities to students to handle and manipulate things.
- **Retentivity:** Audio-visual aids contribute to increased retentivity as they stimulate response of the whole organism to the situation in which learning takes place.
- **Based on maxims of teaching:** The use of audio-visual aids enables the teacher to follow the maxims of teaching like 'concrete to abstract', 'known to unknown' and 'learning by doing'.
- **Helpful in attracting attention:** Attention is the true factor in any process of teaching and learning. Audio-visual aids help the teacher in providing proper environment for capturing as well as sustaining the attention and interest of the students in the classroom work.
- **Helpful in fixing new learning:** What is gained in terms of learning, needs to be made definite up in the minds of students. Audio-visual aids help in achieving this objective by providing several activities, experiences and stimuli to the learners.
- **Saving of energy and time:** A good deal of energy and time, both of the teachers and students, can be saved on account of the use of audio-visual aids as most of the concepts and phenomena may be easily clarified, understood and assimilated through their use.
- **Realism:** The use of audio-visual aids provides a touch of reality to the learning situation. By watching a film show the life of the people of the Tundra region, students learn it more effectively in about two hours than by spending weeks by reading.
- **Vividness:** Audio-visual aids give vividness to the learning situation. A film on Buddha provides a vivid picture of his life and teachings.
- **Meeting individual differences:** There are wide individual differences among learners. Some are ear-oriented, some can be helped through visual demonstrations, while others learn better by doing. The use of a variety of audio-visual aids helps in meeting the needs of different types of students.

NOTES

- **Encouragement to healthy classroom interaction:** Audio-visual aids, through their wide variety of stimuli, provision of active participation of the students, and vicarious experiences encourage healthy classroom interaction for the effective realization of teaching-learning objectives.
- **Spread of education on a mass scale:** Audio-visual aids like radio and television help in providing opportunities for education to people living in remote areas. They also help in promoting adult education.
- **Promotion of scientific temper:** In place of listening to facts, students observe demonstrations and phenomena and thus cultivate scientific temper.
- **Development of higher faculties:** Verbalism promotes memorization. Use of audio-visual aids stirs the imagination, thinking process and reasoning power of the students, and calls for creativity, and inventiveness and other higher mental activities on the parts of students and thus helps the development of higher faculties among the students.
- **Reinforcement to learners:** Audio-visual aids prove effective reinforcers by increasing the probability of reoccurrence of the responses associated with them and thus, render valuable help in the teaching-learning process.
- **Positive transfer of learning and training:** Use of audio-visual aids helps in the learning of other concepts, principles and solving the real problems of life by making possible the appropriate positive transfer of learning and training received in the classroom.
- **Positive environment for creative discipline:** A balanced, rational and scientific use of audio-visual aids develops motivation, attracts the attention and interests of the students and provides a variety of creative outlets for the utilization of their tremendous energy and thus keeps them busy in the classroom work. In this way, the overall classroom environment becomes conducive to creative discipline.

Characteristics

The characteristics of audio-visual aids are:

- They should be meaningful and purposeful
- They should be accurate in every respect
- They should be simple
- They should be inexpensive
- As far as possible, they should be improvised
- They should be large enough to be properly seen by the students for whom they are meant
- They should be up-to-date
- They should be easily portable
- They should be receptive to the mental level of the students
- They should motivate the learners

Principles

The principles of audio-visual aids are:

1. **Principle of selection:** Teaching aids prove effective only when they suit the teaching objectives and unique characteristics of the special group of learners. Following points may be kept in view in this regard, they should:
 - Suit the age-level, grade-level and other characteristics of the learners
 - Have specific educational value besides being interesting and motivating
 - Be the true representatives of the real things
 - Help in the realization of desired learning objectives
2. **Principle of preparation:** This principle requires that following points should be attended to:
 - As far as possible, locally available material should be used in the preparation of an aid.
 - The teachers should receive some training in the preparation of aids.
 - The teachers themselves should prepare some of the aids.
 - Students may be associated in the preparation of aids.
3. **Principle of physical control:** This principle relates to the arrangement of keeping aids safely and also to facilitate their lending to the teachers for use.
4. **Principle of proper presentation:** This principle implies the following points:
 - Teachers should carefully visualize the use of teaching aids before their actual presentation.
 - They should fully acquaint themselves with the use and manipulation of the aids to be shown in the classroom.
 - Adequate care should be taken to handle an aid in such a way as no damage is done to it.
 - The aid should be displayed properly so that all the students are able to see it, observe it and derive maximum benefit out of it.
 - As far as possible, distraction of all kinds should be eliminated so that full attention may be paid to the aid.
5. **Principle of response:** This principle demands that the teachers guide the students to respond actively to the audio-visual stimuli so that they derive the maximum benefit from learning.
6. **Principle of evaluation:** This principle stipulates that there should be continuous evaluation of both audio-visual material and accompanying techniques in the light of the realization of the desired objectives.

Problems

While all these aids are becoming more popular day-by-day, there are still some problems to be faced and solved. These are:

- **Apathy of the teachers:** Teachers in general are yet to be convinced that teaching with words alone is very tedious, wasteful and ineffective.

NOTES

NOTES

- **Indifference of students:** The judicious use of aids arouses interest but when used without a definite purpose they lose their significance and importance.
- **Ineffectiveness of the aids:** Due to absence of proper planning and lethargy of the teacher and without proper preparation, correct presentation, appropriate application and discussion and the essential follow-up work, the aids do not prove their full usefulness. A film like a good lesson has various steps—preparation, presentation, application and discussion.
- **Financial hurdles:** The central and state governments have set up boards of audio-visual education and have chalked out interesting programmes for the popularization of teaching aids, but lack of finances is not enabling them to do their best.
- **Absence of electricity:** Most of the projectors, radio and television cannot work without supply of electricity which is still not available in a large number of schools.
- **Lack of facilities for training:** Training colleges or specialized agencies should make special provision to train teachers and workers in the use of these aids.
- **Co-ordination between centre and states:** Good film libraries, museums of audio-visual education, fixed and mobile exhibitions and educational ‘melas’ should be organized both by the centre and the states.
- **Language difficulty:** Most educational films are in English. We should have these in Hindi and other Indian languages.
- **Not catering to local needs:** Little attention is paid in the production of audio-visual aids to the local sociological, psychological and pedagogical factors.
- **Improper selection of films:** Films are not selected according to the classroom needs.

Future of teaching aids

Today, the problem is not whether visual aids should have a place in education or not. Their place has been recognized long ago. The problem, now, is that of extending the benefits of these aids to all teachers and children. The future can be bright if there is proper planning on the part of the government and co-ordination between producers, teachers and students. Useful and effective aids can be produced after getting the reaction of the audience and doing research work in the field. A great deal is being done already but a lot more still remains to be done.

Classification

Classification Number 1: Projected and non-projected aids

<i>Non-Projected Aids</i>					
<i>Projected Aids</i>	<i>Graphic Aids</i>	<i>Display Boards</i>	<i>3-Dimensional Aids</i>	<i>Audio Aids</i>	<i>Activity Aids</i>
1. Films	1. Cartoons	Black-Board	Diagrams	Radio	1. Computer-Assisted Instruction
2. Filmstrips	2. Charts	Bulletin Board	Models	Recording Television	2. Demonstrations
3. Opaque Projector	3 Comics	Flannel Board	Mockups		3. Dramatics
4. Overhead Projector	4. Diagrams	Magnetic Board	Objects		4. Experimentation
5. Slides	5. Flash Cards	Peg Board	Puppets		5. Field Trips
	6. Graphs		Specimens		6. Programmed Instruction
	7. Maps				7. Teaching Machines
	8. Photographs				
	9. Pictures				
	10. Posters				

NOTES

Classification Number 2: Audio materials, visual materials and audio-visual materials

<i>Audio Materials</i>	<i>Visual Materials</i>	<i>Audio-visual Materials</i>
(1) Language laboratories	(1) Bulletin boards	(1) Demonstrations
(2) Radio	(2) Chalk boards	(2) Films
(3) Sound distribution system sets	(3) Charts	(3) Printed materials with recorded sound
(4) Tape and disco recordings	(4) Drawings etc.	(4) Sound filmstrips
	(5) Exhibits	(5) Study trips
	(6) Filmstrips	(6) Television
	(7) Flash carts	(7) Videotapes
	(8) Flannel boards	
	(9) Flip books	
	(10) Illustrated books	
	(11) Magnetic boards	
	(12) Maps	
	(13) Models	
	(14) Pictures	
	(15) Posters	
	(16) Photographs	
	(17) Self-instructional	
	(18) Silent films	
	(19) Slides	

NOTES

Classification Number 3: Hardware and software in teaching aids

Educational technology can be classified into two categories, i.e., the hardware approach and software approach. You have already read about these approaches in a previous section of the unit.

Hardware approach: It is based on the application of engineering principles for developing electro-mechanical equipment for instructional purposes. This approach is the result of the impact of scientific and technological development during the present century. Hardware approach mechanizes the process of teaching so that teachers would be able to deal with more students with less expenditure in educating them. Hardware devices include the following:

- Computers
- Epidiascope
- Magic lantern
- Motion pictures
- Overhead projector
- Radio
- Slide and film projector
- Tape recorders
- Teaching machines
- Television

Software approach: This uses the principles of psychology for building in the learner a complex repository of knowledge modifying his behaviour. It has originated from the pioneering work of Skinner and other behaviourists. The programmes which such a technology produces, are often called 'software'. Software approach is characterized by task analysis, writing precise objectives, selection of appropriate learning strategies, immediate reinforcement of responses and constant evaluation. Newspapers, books, magazines, educational games, flash cards may also form part of software.

Classification Number 4: Big media and little media

Big media includes computer, VCR and TV. Little media includes radio, films strips, graphics, audio cassettes and various visuals.

Classification Number 5: Three Dimensional Aids

- Models
- Mock-ups
- Specimens

Three dimensional aids are the replicas or substitutes of real objects.

1.7.2 Blackboard

Blackboard is a unique device which in spite of newer and better devices in vogue is irreplaceable as well as indispensable. It is the oldest and the best friend of a teacher.

It is a mirror through which students visualize all about the teacher's mind, his way of explaining, illustrating and teaching as a whole. It is the cheapest and the most valuable teaching device and continues to be the 'sine qua non' of our educational system. It is the most universally used aid. Writing on sand and clay was the ancient form of blackboard writing.

The use of blackboard in class teaching creates an informal atmosphere and motivates learning. Teaching no longer confines to any one instructional device. It is a help to 'planning', to 'crystallizing' main points and to 'summarizing' and 'reviewing' results. Blackboard being a simple means of dealing with the whole class as a unit, is extensively used during the course of a lesson.

Following are the uses of blackboard:

- The teacher can illustrate his lesson on the blackboard and draw the attention of the class to salient features in the lesson.
- The lesson can be divided and summarized in the right manner. Abstract statement can be clarified in the expository stage and a summary containing important points can be given in the recapitulatory stage.
- Questions and problems when planning class work or approaching a new subject can be listed by the teacher on the blackboard.
- Pupils' interest in class work can be stimulated by blackboard writings and drawings.
- It can be put to wide and varied uses. A teacher can use it for graphs, maps, graphic statistics, sketches and various types of drawings.
- It provides a lot of space for decorative and creative work.
- The teacher can erase writings and drawings and start afresh.
- It helps the teacher to focus the attention of his students on the lesson.
- A teacher can review the whole lesson for the benefit of the class with the help of the blackboard.

Types of blackboards

- **Fixed blackboard:** Fixed in the wall facing the class and normally made of wood or concrete cement.
- **Blackboard on easel:** A portable and adjustable blackboard put on a wooden easel can be taken out of the classroom while taking classes in the open.
- **Roller blackboard:** Made of thick canvas wrapped on a roller mostly used for teaching higher classes.
- **Graphic board:** It has graphic lines and is used for teaching mathematics, science and statistics.
- **Magna board:** A board which enables teachers to make three-dimensional demonstrations with objects on a vertical surface. Small magnets are used to hold suitable objects fixed wherever they are put on this vertical surface.

Following points may be kept in view while using the blackboard:

- Blackboard should be kept clean so that writing on it could be easily read by the students from all parts of the room.

NOTES

NOTES

- Writing on the blackboard should be legible.
- Letters and drawings should be large enough to be seen from all parts of the room.
- Begin writing from the top left corner.
- Writing should be in straight rows.
- Extreme lower corner of the blackboard should not be made use of as writing on it cannot be seen easily.
- Material on the blackboard should not be covered by standing in front of it.
- Only salient points of the subject-matter should be written on the blackboard.
- Diagrammatic visual presentation involving many processes should be prepared before the beginning of the lesson.
- It should be ensured that the blackboard is well-lit by natural or artificial means.
- Everything needed for the blackboard should be made available before the class begins i.e., collection of chalk, rulers, compass, and projector.
- While writing on the blackboard, the teacher should ensure that the class is attentive.
- Duster and not hand or handkerchief should be used in cleaning the blackboard.
- Occasionally students may be asked to write or draw a diagram on the blackboard.
- Teachers should develop the ability to draw freely on the blackboard. The map or chart or diagram that grows before the very eyes of the students is much more useful and valuable than a well finished map, chart or diagram.
- It should be ensured that the blackboard is periodically serviced.

1.7.3 Charts

A chart is a combination of pictorial, graphic, numerical or vertical material which presents a clear visual summary. The most commonly used charts include outline charts, tabular charts, flow charts and organization charts. Other types of charts are technical diagrams and process diagrams. Flip charts and flow charts are also being used. Readymade charts are available for use in teaching in almost all subjects. But charts prepared by a teacher himself incorporating his own ideas and lines of approach of the specific topic are more useful.

Charts serve the following purposes:

- For showing relationship by means of facts, figures and statistics
- For presenting material symbolically
- For summarizing information

- For showing continuity in process
- For presenting abstract ideas in visual form
- For showing development of structure
- For creating problems and stimulating the thinking process
- For encouraging utilization of other media of communication
- For motivating the students

How to use charts effectively

A chart can be used in the following ways:

- Teacher-made charts should be preferred.
- Students should be involved in the preparation of charts.
- Charts should be so large that every detail depicted should be visible to every pupil in the class wherever he is sitting.
- Charts should display information only about one specific area in a subject.
- A chart should not contain too much written material.
- A chart should not contain too many details.
- A chart should give a neat appearance.
- When a chart is to be used in the classroom, the teacher should make sure that there is provision for hanging the chart at a vantage point.
- The teacher should have a pointer to point out specific facts in the chart.
- Straight pins, staples, pegboard clips, gummed hangers, paper-clips, folded making tapes may all be used for fastening charts without damaging them.
- Charts should be carefully stored and preserved for use in future.

Types of charts

The following is a list of basic types of charts in terms of arrangements and the kinds of ideas which they may express:

1. The narrative chart, an extended left-to-right arrangement of facts and ideas for expressing:
 - The events in a process such as shoe making, oil cracking, or the like.
 - The events in the development of a significant issue to its point of resolution or to the present status (sometimes a time limit). For example, the events leading to the separation of Bangladesh from Pakistan, the events leading to the establishment of the idea that an individual should be free and that he should have a voice in his own government and the events leading to increased regulation of business by government.
 - Technological improvement over a period of years such as improvement in transportation, communication, manufacturing.

NOTES

NOTES

2. The tabulation chart, a left-to-right, top-to-bottom arrangement of facts and ideas for expression of:
 - Numerical data for making comparisons
 - Lists of products, mountains, rivers, or the like in selected areas
3. The cause and effect chart, usually a limited left-to-right arrangement of facts and ideas for expressing:
 - Relationship between standard of living and such factors as economic system, availability of natural resources, level of technological advancement
 - Relationship between a culture and neighbouring cultures
 - Relationship between rights and responsibilities
 - Relationship between a complex of conditions and change or conflict
 - Relationship between the elected and the electors
 - Relationship between community workers and the community which supports them
4. The chain chart, a circular or semi-circular arrangement of facts and ideas for expressing:
 - Transitions, such as the transition from raw materials to useful products
 - Cycles, such as the water cycle
5. The evolution chart, a left-to-right arrangement of facts and ideas for expressing:
 - Changes in specific items from beginning to date, perhaps with projections into the future; for examples, automobile and its subsequent development, early basic homes and changes in basic homes to date
 - Change in the standard of food consumption, length of work, weak purchasing power of a rupee, or the like

1.7.4 Epidiascope

The epidiascope is an instrument which can project images or printed matter or small opaque objects on a screen, or it can project images of a 4' × 4' slide. With the help of an epidiascope, any chart, diagram, map, photograph and picture can be projected on the screen without tearing it off from the book. No slide is needed for this purpose. An epidiascope serves two purposes. It works as epidiascope when it is used to project an opaque object. It works as diascope when it is used to project slides (by operating a lever). It works on the principle of horizontal straight line projection with a lamp, plane mirror and projection lens. A strong light from the lamp falls on the opaque object. A plane mirror placed at an angle of 45° over the project, reflects the light so that it passes through the projection lens forming a magnified image on the screen. (Figure 1.10)

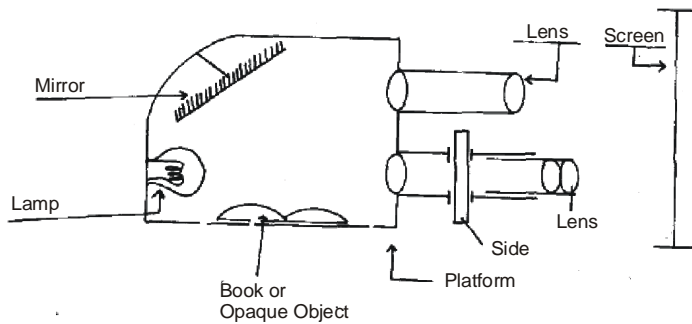

Fig. 1.10 Epidiascope

NOTES

1.7.5 Film Strip

A film strip is 35 mm wide and has a series of 12 to 48 picture frames arranged in a sequence so that they develop a theme. A film strip can be prepared by taking a series of photographs using a 35 mm camera and then by taking a positive print of the negative film on another 35 mm film.

Globe

Knowledge of map is unreal without the knowledge of globe—the true map. It is the true representative of earth's physical personality.

A globe gives a true idea of the total environment at a glance in a classroom situation. It is through globe that a child can understand the concepts of time, and space. Hence, every school shall have globes. Four types of globes may be kept in every school: (1) political globes, (2) physical globes (3) washable projection globes, and (4) celestial globes.

Graphs

Graphs are flat pictures which employ dots, lines or pictures to visualize numerical and statistical data to show relationships or statistics.

Graphs are of several types:

- **Line graph:** In a line graph, data is represented with the help of simple lines horizontally or vertically drawn. For increasing the interest and readability of concepts, pictorial illustrations and cartoons are occasionally used on the line graph.
- **Bar graph:** A bar graph consists of bars arranged, horizontally or vertically from a 'zero' base. The colour, length and size of the bars represent different values. (Fig. 1.11)
- **Circle graph:** Data may be presented in a circle graph. (Fig. 1.12)

NOTES

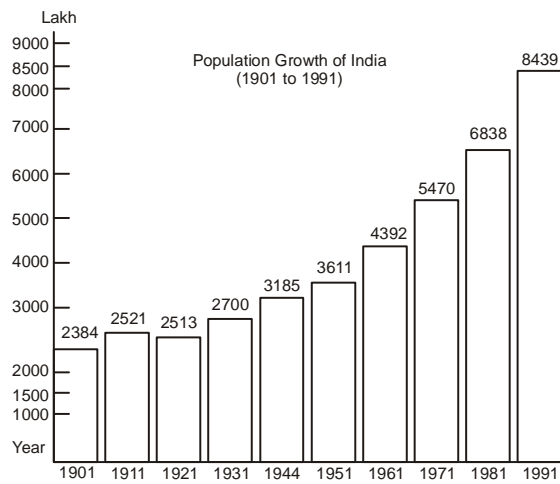

Fig. 1.11 Illustration of a Bar Graph

Literacy in India (1991)

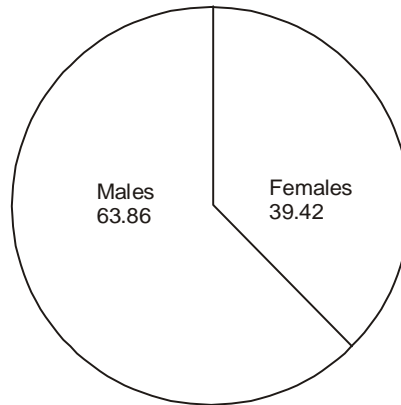

Fig. 1.12 Illustration of a Circle Graph

Magic lantern

Magic lantern is the earliest invention in the history of audio-visual aids used for projecting pictures from a transparency (slide) on a wall or screen. When the figure or illustration is very small and it is required to be shown to the entire class, a transparent slide of the small figure is prepared. Then, this slide is placed into the slide carrier part of the magic lantern. This magic lantern device projects it on the screen by enlarging its dimension and making the vision more clear and sharp.

1.7.6 Map Study

In several subjects, especially social studies, learning of many geographical, historical and economic concepts remains unreal, inadequate and incomplete without a map. A resourceful teacher by motivating the pupils will turn the fear of map into a genuine love for them. This, however, pre-supposes the invariable use of maps at every possible opportunity by the teacher in the classroom, and the possession of individual atlases by the pupils. Every student should also know certain elementary aspects of

map preparation such as copying, enlarging and reducing, symbolizing, colouring, and preparation of key components. Most of the students develop an aversion to maps because they are not aware of the skills required for map preparation.

A map is an accurate representation plain surface in the form of a diagram drawn to scale, giving the details of boundaries of continents and countries. Geographical details like location of mountains, rivers, altitude of a place, contours of the earth surface and important locations can also be represented accurately with reference to a convenient scale with suitable colour scheme.

NOTES

Identification of various aspects of maps

- Understanding and interpreting the key of index
- Understanding the lines—boundary lines, lines of communication, lines indicating the rivers, contours, meridians and parallels
- Understanding the colours, tints, shadows, symbols on a map or globe
- The top of every map is not north, but the direction of north pole is north
- Distinction between the various types of maps such as relief, political, and distribution maps
- Understanding of the position of earth in the universe

Many students suffer from a notion that the earth leans in June towards the sun northwards and in December southwards and thus, seasons are formed. Earth never tilts that way. The student shall understand that the inclination of earth is constant and the leaning effect changes due to its rotation around the sun.

Types of maps

- **Relief maps** (regional and the world): This requires knowledge of colours, contours, symbols and other concepts related to making maps.
- **Historical maps**: Maps in history reveal the changing times and the growth and decline of various kingdoms. Knowledge of lines of boundaries and other symbols is necessary.
- **Distribution maps**: Generally, the student shall associate with the following types of distribution maps:
 - o Vegetation maps
 - o Population maps
 - o Economic maps
 - o Statistical maps
 - o Dot maps
 - o Pictorial maps
 - o Language, race and other human division maps, etc.
- **Geographical maps**: Contour maps, weather maps, seismological maps, archaeological maps, rainfall maps, geological maps, etc.

NOTES

1.7.7 Microfilm

The microfilm and microfiche are used widely for storage and retrieval of information. Microfilms contain photographed reading material on a 35 mm film, each frame being the reduced photograph of a printed page. Thus, printed matter of a book can be stored in a small loop of 35 mm film. When the microfilm is passed through a microfilm reader, an enlarged image approximately of the size of the printed page is formed on a ground glass (rear-view) screen and the observer can read the matter. By moving the film through the microfilm reader, images of different pages can be obtained and read.

Models

Models are substitutes for real things. A model is a three-dimensional representation of a real thing. Models are concrete objects to explain clearly the structure or functions of real things. A model is a replica of the original. Models enable students to have a correct concept of the object.

Being three dimensional, models evoke great interest and simplify matter. Models enable us to reduce or enlarge objects to an observable size. It may not be possible or even practicable to make students see the whole of a large industrial unit or even a large machine unit, but a model will give the correct perspective. Preparation of models could form a topic for project work. It is essential to create interest in creative activity in students.

Models are working as well as static. A working model will secure immediate attention and serve as motivation to learn.

A model can be prepared with several kinds of material like cardboard, plastic, plaster of paris, wood, clay, and thermocole.

1.7.8 Projector

These are different kinds of projectors, some of them are:

- (a) **Micro-projector:** The combination of a microscope and a slide projector is an instrument called micro-projector. The microscope is used to see very minute parts of objects by magnifying the same hundreds of times. The minute part usually of a plant or an animal is put on a glass slide and a magnified image formed by a combination of lenses in a microscope which can be seen by an individual through the naked eye. The micro-projector attachment consists of a projection lens, a plane mirror fixed at 45 degrees to the vertical plane and a vertical ground glass screen. It is very useful in teaching science. (Fig. 1.13)

NOTES

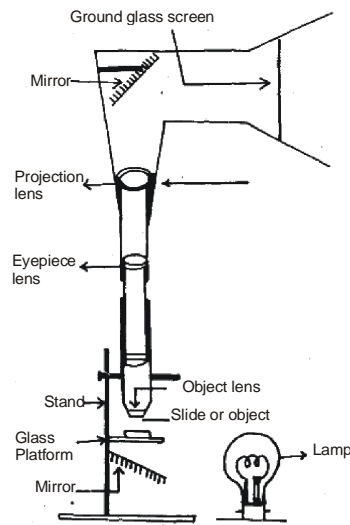

Fig. 1.13 Micro Projector

(b) **Overhead projector (OHP):** Overhead projector is a device that can project a chart, diagram, map, table or for that matter, anything written on transparent plates, upon a screen or the white wall before students in a class. This makes teaching illuminative, illustrative and impressive. It also saves a great deal of the teacher's time used in drawing or writing them. These transparencies can also be preserved by the teacher for future display while taking up the same topic. It is very simple to prepare such transparencies. All that a teacher has to do is to draw or write, as the case may be, upon transparent plates with any dark ink with a fibre tipped pen. Any material meant for display before the class while teaching can also be typed on such transparencies using a good carbon paper. In case transparencies are to be washed out for use, washable water colour can also be used for writing on the transparencies. (Fig. 1.14)

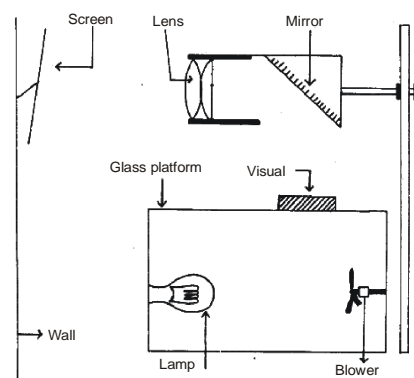

Fig. 1.14 Overhead Projector

NOTES

(c) **Slide projector:** With a slide projector, photographic slides can be projected on the screen or the wall before the class. Photographs of relevant matter meant for teaching in the class can be developed on celluloid slides and displayed with the help of such a projector. The teacher's lesson can also be recorded on an audio cassette and played with a tape recorder suitably synchronizing with the slides by manipulating a remote control switch. Such an arrangement is called a tape-slide sequence. In case there are several slides to be shown in quick succession, the tape-slide sequence can bring as interesting an effect on the viewers as do the movie films.

An ordinary slide projector has a frame containing two slits into which slides are put for focusing. They are manually and continuously replaced by other slides one after another.

An improved type of a slide projector consists of a circular disc with more slits where even a hundred or more slides can be inserted in a sequential order which can be projected on the screen with the help of a remote control switch to be suitably manipulated by the teacher as he delivers the lesson. (Fig. 1.15)

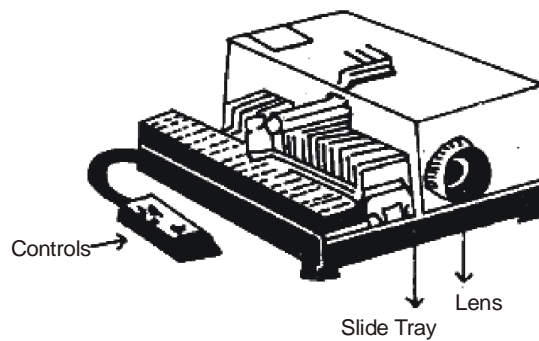

Fig. 1.15 36 mm Automatic Slide Projector (Linear Slide Tray)

1.7.9 Reprographic Equipment

Reprography is a branch of technology dealing with the methods of duplication or reproduction. Duplication involves making a number of identical copies of the original. Reproduction enables preparation of one or more identical copies of the original, same size or of different size in monochrome or colour. Equipment and processes included are duplicators, reflex printing and photography.

Record player

Record players are a means of audio playback. They are older types of hardware using records of discs for the needed playback. Four sizes of records 7², 10², 12² and 16² are in common use. There are also high speed records played with standard stylus. The record players now in use are equipped with speed changer mechanisms permitting the playing of the slower long-playing 45, 33¹/₃ and 16²/₃ r.p.m. records played by microgroove stylus. The use of recorded pieces in education has great value in language learning, appreciation of poetry and literature and presentation of brief dramatized episodes from history, from development of musical knowledge

NOTES

and discrimination. Long-playing records with 20 minutes of recorded information per side provide several diverse selections inscribed on each side and are very suitable for classroom instructional purposes. The needed selection for a particular learning situation can be easily identified by the specific microgroove ring it occupies on the record. 'Talking books' for the blind also consist of recordings of essential literature for the visually handicapped. The older, manually wound spring powered gramophone's place now has been taken up by electrically powered multi-speed record players and changers with built-in amplifying unit or linked to separate amplifying units and speakers. Likewise, the older mechanical recording has given place to electrical imprinting involving greater clarity and fidelity.

Tape-recorder: A tape-recorder in its own can be very effective for classroom instruction. Pre-recorded tapes consisting of lessons by eminent teachers on any subject can be played in the class. Such instructions become impressive not only because of the novelty but also because of their being well-thought out and planned.

The tape-recorder has proved to be a boon in teaching foreign languages like English. Pre-recorded tapes on English lessons can be played in the classroom to teach not only the contents of the lesson but also proper accent, pronunciation and intonation which an average English teacher very much lacks. (Fig. 1.16)

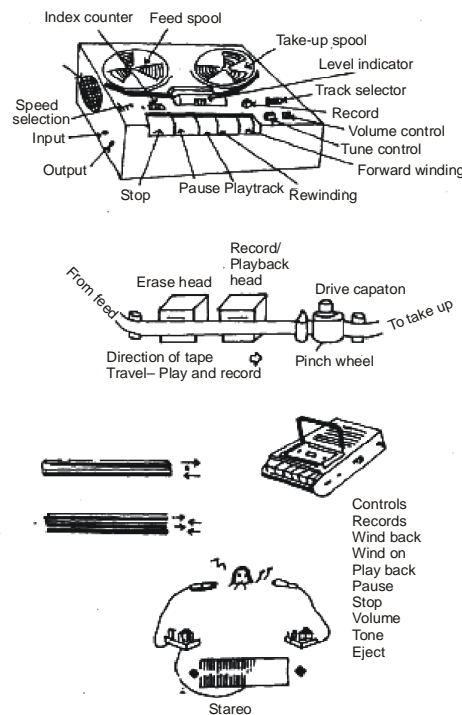

Fig. 1.16 Components of a Tape-recorders

Video tapes played through TV: Pre-recorded video tapes can be played through TV in the classroom. Video films on educational topics shown through TV in the classroom have a similar effect on students as the ordinary cinematic educational films. Video films have the added advantage over ordinary films in that the arrangement

is compact and requires little space and time for manipulation. It is the most convenient of all audio-visual teaching-learning material.

Video cassettes

NOTES

The potential advantage of video cassette lies in the fact that control of the equipment and the learning process is placed in the hands of the learner through control over the mechanics of the machine, i.e. stopping, starting, timing, reviewing and previewing and consequently the capacity to order the sequence of events, controls the rate of learning, and facilitates practice sequences.

The potential exists for providing the basis for learning a wide range of motor, intellectual and cognitive and interpersonal skills, as well as affective aspects. These are important aspects which printed materials cannot deal with adequately.

This facility could be particularly useful where distance education programmes are involved with updating skills and techniques of workers in the field. For example, new horticultural techniques can be transmitted to field workers to improve farming techniques.

In some countries as a way of regionalizing a centrally produced programme, video cassette programmes are being built round the study centre concept, a location where several video machines are available to which students bring their study notes. The students run the programmes as individuals. Sometimes study centres provide for group sessions during which video cassettes are played. Unless some supplementary teaching is provided, this technique can become another version of broadcast technology.

In other countries, some institutions assume that students can gain access to such equipment and make programmes which will be used on an individual basis as either supplementary learning material or integral to the teaching programme.

The problems associated with video cassettes are of two kinds: (i) cost; and (ii) production of programmes.

- Equipment costs cannot always be kept down by using lower quality equipment. Cheaper equipment formats do not enable technical material such as animal or plant tissue to be represented adequately or tapes to be reproduced in quantity without loss of fidelity.
- Video production for educational purposes calls for new techniques different from the entertainment modes. Producers, directors, scriptwriters need to be knowledgeable about teaching and learning. Many of the old techniques of film and television will no longer be of use. For example, the very basic concept that programmes must have a beginning, a middle, and an end will no longer apply as a cassette could just as easily consist of a series of short video events which sets a problem, teaches a technique, or brings together a range of visual material to make concepts or principles clear.

1.7.10 Three-Dimensional Aids

Three dimensional aids serve as good substitutes for the real objects. There is no doubt that an encounter with real objects serves as an unmatched source of learning. But on account of several reasons it may not be possible to bring the real objects in the classroom. The real objects may be too large to move or store in the classroom. It may be too small to be seen for a group of students. It can be too complicated in real form to be understood. It may be too swift for its operations to be understood. Its movements may be too slow to be studied completely. It can be too expensive to be purchased by an educational institution. Being handicapped in such situations a teacher has to search for some good substitute for the real objects.

Models, diagrams, mock-ups and specimens are the important three dimensional aids.

Models: Models are the replicas or copies of the real objects. Models are usually of three types: solid, cross-sectional and working. Models are concrete objects, some considerably larger than the real object. Sectional models explain clearly the structure or functions of the original. In some cases working models of the original are used where the specific function of the original is duplicated and could be explained easily.

Following are the important functions of models:

- Models simplify reality
- Models concretize abstract concepts
- Models enable us to reduce or enlarge objects to an observable size
- A model provides the correct concept of an industrial unit or a bridge or a dam like the Bhakra Dam
- A working model explains the various processes of objects and machines
- Preparation of models could form a topic for project work. This is very helpful to create interest in creative activity among pupils

Cardboard, plastic, plaster of paris, wood, thermocole and metal can be used in the preparation of a model.

Mock-ups: A mock-up refers to a specialized model or working replica of the object being depicted. In a mock-up, a certain element of the original reality is emphasized or highlighted to make it more meaningful for the purpose of instruction. While a model is a recognizable imitation of an object (though larger or smaller than the original one), a mock-up may or may not be similar in appearance. Mock-ups of aeroplanes, auto-mobile engines, bridges, ships and tunnels, may be demonstrated for explaining their structure and actual working. Mock-ups are often used in technical institutions for training purposes.

Dioramas: A diorama is a three dimensional scene in depth incorporating a group of modelled objects and figures in a natural setting. The diorama scene is set up on a small stage with a group of modelled objects kept on the foreground which is blended into a painted realistic background. Dioramas are very effective in the teaching of biological and social sciences.

NOTES

NOTES

Source of three dimensional objects

The sources of three dimensional objects are:

- These objects may be borrowed from audio-visual aid centres, libraries and museums
- They may be purchased from the concerned commercial establishments
- They may be prepared by the teachers and students

Selection and use of three dimensional objects

The selection and use of three dimensional objects can be done in the following ways:

- Dimensional aids may be selected, keeping in view the instructional needs and requirements.
- As far as possible, they should be a true representative of the actual objects.
- The complexity of the aids should match the level of maturity of the students.
- The aids should make an appeal to as many of the five senses as possible.
- As far as possible, aids should be prepared by the students under proper supervision of the teacher.
- Every possible effort should be made to prepare students educationally as well as psychologically for receiving instruction or message to be conveyed by the use of these aids.
- Aids should be inexpensive.
- Aids should be prepared with locally available material as far as possible.
- Necessary instructions should be given to students to handle aids with care.
- Necessary clarification may be given by the teacher at the presentation of these objects in the class.
- Necessary demonstration in the use of these aids should be given to students.
- Student's comprehension should be properly tested at the end of the use of aids.
- Adequate storage arrangement should be made for their safe custody.

1.7.11 Radio's School Broadcast Programmes

There is hardly any doubt regarding the potential of radio as an instructional aid. Frederick Wittis has rightly remarked: 'I like to think of education by radio as a timely, vital and dramatic thing; a system of learning or acquiring more information, a means of widening one's horizon or enriching one's life and breaking down prejudices through inspiration and not perspiration; an education by desire and not by discipline; a pattern or swiftly changing pictures, events with keen interpretations, not statistics and formulas; a moving panorama of the world in which we live—right now, while we are living in it—not a dreary drill of textbooks and tests. In short I feel that one of the most helpful contributions of broadcast to education and one of its real responsibilities to itself and its listeners is the popularizing of education itself.'

R. G. Reynolds writes: 'Radio is the most significant medium for education in its broadest sense that has been introduced since the turn of the century. As a supplement to classroom teaching its possibilities are almost unlimited. Its teaching possibilities are not confined to five or six hours of the school. It is available from early morning to midnight. By utilizing the rich educational and cultural offerings of radio, children and adults in communities, however remote, have access to the best of the world's stores of knowledge and art. Some day its use as an educational instrument will be as common place as textbooks and blackboards.'

NOTES

Merits

The merits of the radio's school broadcast programmes are:

- Bringing the school in contact with the world around
- Helping in the spread of elementary education
- Helping in the promotion of adult education
- Assisting in the spread of non-formal education
- Enrichment of school programme
- Furnishing up-to-date material
- Developing critical thinking
- Developing leisure time interest and appreciation
- Providing opportunities for student participation
- Providing an alternative approach to the education of out of school children
- Imparting vocational skills
- Popularizing science with a view to develop a scientific outlook
- Promoting emotional and national integration
- Providing information about population education, energy conservation, and preservation of wild life
- Serving as a training component for teachers

Demerits

The demerits of the radio's school broadcast programmes are:

- Radio broadcast is a one-way communication. Students cannot put questions to the broadcaster.
- The educational value of radio broadcasting depends merely on the use of sense of hearing.
- The students have little opportunity to participate in the instructional activity. They are passive listeners for most of the time.
- In several cases, broadcasting time does not suit all educational institutions.
- The number of receiving sets is not adequate in the case of several educational institutions.

NOTES

- It becomes very difficult to integrate school programmes with radio broadcasts.
- Continuous listening on the part of the students may make them inattentive and uninterested in the task of gaining learning experiences.
- Usually there is paucity of adequate pre-information, manual or guides regarding radio broadcasts with the result that the students and teachers both face difficulties in making necessary preparation for the utilization of these programmes.

Suggestions for effective school broadcasting programmes

Following are the suggestions for effective school broadcasting programmes:

- The school broadcasts should not be merely course lessons but should have a wider horizon of application in day-to-day life.
- The school broadcasts should be planned according to the needs of the syllabus, students and concerned teachers.
- Teachers should occasionally meet, discuss and plan the type of assistance required on mass media instructional facilities.
- The radio programmes should be intended to give supplementary information to various topics in the syllabus.
- Good planning and administration is highly needed so as to make the programmes effective and worthwhile.
- Broadcasting tune should be suitable to schools. Adequate feedback should be provided.
- There should be proper follow-up on school broadcasting programmes.
- Adequate listening facilities should be provided in schools.
- Broadcasts should be made in easy and simple language.
- Broadcasts should be made in a pleasing style.

In short all the six main stages of a radio broadcast namely, production, preparation, listening to the programme, feedback, consolidation of acquired knowledge and evaluation should be carefully attended to.

History: Ever since the start of school broadcasting by British Broadcasting Corporation (BBC) in 1920, it has made rapid strides in making sound contribution to formal education. In USA, in 1923, there were programmes in accounting from New York programmes in arithmetic and literature from Oakland, in 1924, music appreciation lessons in 1925 from Cleveland. By 1952–20 states in USA had provision for educational broadcasting. Around the same time about 98 per cent of the schools in the UK were equipped with radio and there were regular daily programmes.

Bombay Station started broadcasting programmes of special interest to school children occasionally from January 1929. From April 30, the Corporation of Madras had regular school broadcasts for half an hour on all weekdays. Similar programmes were introduced by the Calcutta Station in 1932.

The programmes for schools produced by Akashwani Stations are for the following categories of people: (a) children of primary classes; (b) children of secondary and higher secondary classes; (c) preparing lessons for secondary and higher secondary classes near examination time; (d) teachers; and (e) general enrichment programme for children.

These broadcasts can either be 'live' or 'transcribed' depending on the physical presence of the person broadcasting or his recorded speech. Broadcasting organizations throughout the world, including AIR, include in their output various school broadcasts. Such programmes are normally arranged in consultation with the heads of various institutions. This liaison between the radio and educational authorities helps in bringing out effective and useful programmes for the pupils. The planning of such talks is undertaken with great care and by persons of repute. The programmes are prepared term wise and copies are supplied to schools sufficiently in advance to enable the teachers to discuss the subject with the pupils.

NOTES

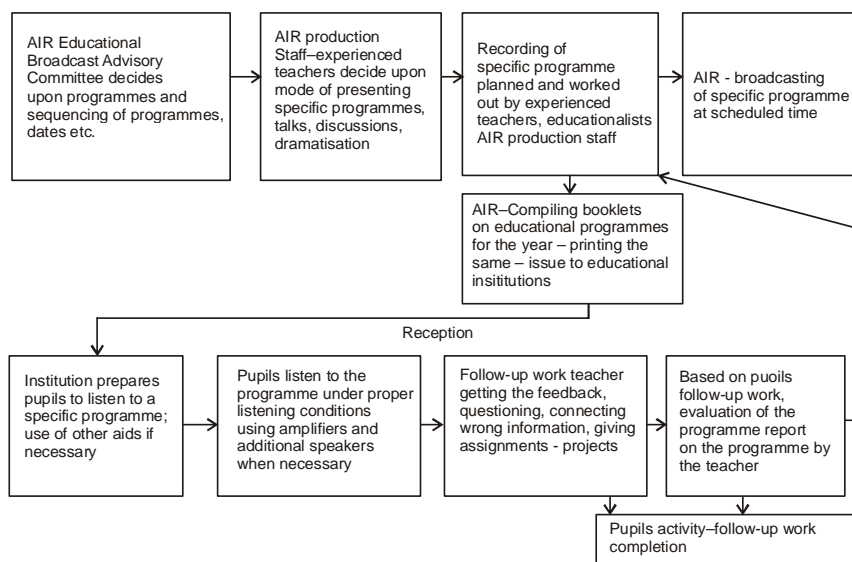

Fig. 1.17 Flow Chart of Educational Broadcast Programmes in India

1.7.12 Educational Television (ETV) or Instructional Television (ITV)

TV has become a child's third parent and a first teacher. The history of television shows that it is a very powerful, informative, socializing and mobilizing force. Most of the countries of the world have opted for television to solve their difficulties and problems relating to education. Direct television instruction started four decades back in progressive countries like the UK and the USA. The regular programmes were on air in November 1936 by BBC. Remote areas were provided with television sets. By 1958, more than 98 per cent of the population was covered by television transmission. By 1961, Moscow and the UK shared programmes with each other. By 1962 American engineers, succeeded in bouncing television waves across the Atlantic on a Satellite-Telestor. In 1967, the first regular service of coloured television in Europe began on BBC-2.

NOTES

For the first time, television for instructional purposes was used in the USA. A large number of experiments in instructional television were conducted there. In 1958, a project entitled continental classroom started instructional television for the whole of the USA. It telecasted a programme *Physics of the Atomic Age* for science teachers. About 40,000 teachers received instruction through this programme. Later on, several programmes such as modern chemistry, contemporary mathematics and new biology were also telecast by this project. In 1961, a project called *Mid-west Airborne Instructional Television* started instructional television. About 13,000 schools received the programmes benefiting about five million students, at a cost of 7.5 million dollars or at an expenditure of 1.5 dollar per student. At present there are hundreds of instructional television programmes being telecast in USA and other countries.

Significance: Television is the most potential instrument in educating masses and thereby narrowing down the gap of progress between the developing and developed countries of the world. For a country like India which has vast and inaccessible areas, different climatic conditions, large and ever growing population, T.V. can be an important central media in providing functional, formal and non-formal education to the masses. It can also help in bringing about social and cultural changes bearing on art, music, drama and literature. It is through television that stimulating and thought-provoking views of renowned statesmen, scientists, educationists, artists and teachers can be shared by all. Television helps in enforcing the public understanding of social, political and scientific advancement of a country.

Merits

The merits of the Educational Television (ETV) or Instructional Television (ITV) are:

- It permits the use of the best available teacher to teach a subject for a large number of student viewers. It preserves the expert teaching skills of such teachers on video tape or film for later use.
- It provides a common experience to all students when they all see the same basic ideas or techniques on television.
- It provides the teacher an opportunity to observe the instructional methods and ideas of their experts and to increase his own knowledge of teaching methods and stimulate new ideas.
- It provides technical advantages not readily available in normal classrooms for illustration or demonstration.
 - o It makes possible close-up magnification of small objects, components, intricate mechanisms, diagrams, giving student a 'front-row seat'.
 - o It allows instantaneous change of perspective by switching from a wide camera angle to a close-up or by 'zooming' in.
 - o It permits relationships between two illustrations or time-lapse between two stages of a process by dissolving one picture into another.

- o It provides for comparison of two or more illustrations by super-imposure or 'spilt screen' effects.
- It directs the attention of the student to the exact detail of object which he should see by eliminating distracting surroundings.
- It makes quick and lasting visual and rural impressions which can often reduce the time necessary to teach an idea or technique.
- It makes it possible to bring large, scarce, new or confined equipment 'into the classroom' electronically.
- It incorporates useful film sequences, slides, graphic art and makes available teaching aids within a television presentation, tailored to meet the needs of a particular course or subject.
- It saves time, effort and cost of setting up classroom projection equipment.
- It brings instructional films into classrooms as needed with no special classroom preparation, no darkening of rooms or use of special ventilation in the room.
- It provides more 'immediacy' than instructional films.
- It brings live demonstrations, video-tape or film presentations to the classroom at the instant or immediately after they occur.
- It permits inclusion of up-to-date information, modifications, new equipment or techniques into the classroom instruction.
- It allows the teacher time to observe individual students or to assist them during the television presentation, or to determine what needs further application after the presentation.

NOTES

Limitations of ETV

The limitations of the Educational Television (ETV) or Instructional Television (ITV) are:

- The medium is limited to one-way communication from teacher to students. Students cannot put any question to the teacher.
- The total cost of teaching by television is more than normal classroom instruction, unless television is used to reach large number of students at one time or sequentially over a period of time.
- Television has special and unique techniques and requires occasional re-arrangement of subject sequence.
- Individual differences of the students are not attended to in a TV lesson.
- TV lessons may not suit the school timings.
- TV lessons are not flexible.
- Instruction through TV is not child or learner centred.

NOTES

Kinds of educational TV programmes

The kinds of educational TV programmes are:

- Total TV teaching
- TV as a complementary basic resource
- TV as a supplementary environment

Role of the teacher in school TV programmes

School TV programmes have five main stages and it is necessary that the teacher should be associated with each stage.

- Planning and preparation
- Presentation
- Production
- Utilisation
- Evaluation

1. **Planning and preparation of programmes:** No TV programme for schools can be planned and prepared unless the classroom teacher is effectively associated with this work. To plan and prepare a good TV lesson, a thorough knowledge of the requirements of the students of different age levels, the suitability of the materials, the sequence and the contents are very vital and this can be met fully only by the classroom teacher. Experience tells that the classroom teacher can contribute effectively in this area if he has a good grounding and knows very well the mechanics of a good TV lesson.
2. **Production:** Production is a technical thing but the knowledge about the mechanics of production must be known to the classroom teacher if he is to appreciate a good lesson, i.e., to locate its strong and weak points and suggest improvements.
3. **Presentation:** Again, in the presentation of a TV lesson it is only the classroom teacher who can deliver the goods—no doubt a teacher with initiative, imagination and subject competency is required. The presentation involves only a selected number of teachers but the scope of selection involves all the teachers of a subject. A good selection can be possible only from a TV trained group. It is noted that without necessary training in this field even a very good and competent teacher in a school fumbles and stumbles in the studio.
4. **Utilisation of TV programme and the teacher—Pre-telecast and post-telecast:** Utilization is the area where the teacher is the master of the situation. It may be emphasized that no TV lesson is complete without the introduction and follow-up exercises in the classroom by the subject teacher. An average lesson with proper and well-thought introduction and follow-up can become a very effective lesson whereas a good lesson in the absence of one or both can go flat. The teacher has to inspire the students, prepare them and arouse their curiosity before the telecast of the lesson and afterward has to clarify the doubts, if any, provide the missing links and reinforcement in the follow-

up. He also has to integrate the TV lesson with his classroom teaching. He also has to take care of many other factors and provide congenial conditions to enable his students to really benefit from a TV lesson.

5. **Evaluation:** Evaluation is another important area. If tackled properly, it contributes considerably to the quality and usefulness of TV lessons. No evaluation is possible or worthwhile without the involvement of the classroom teacher. Moreover, simply involvement of the classroom teacher does not help much unless he is fully conversant and properly trained to evaluate and assess the TV lesson from all angles and has acquired competency to do the job well. Without proper training the teachers even fail to fill up the check-sheets properly—an exercise to be completed by the classroom teacher after every lesson.

NOTES

Physical facilities for effective television education

Once the television becomes an integral part of classroom teaching, the physical facilities available in the schools are as important as the quality of the programme, from the utilization point of view. No matter how rich and valid the TV programmes are, they cannot reach the audience unless optimum physical facilities are available to the viewers. The availability of physical facilities appears to be quite simple yet it requires a constant vigil to keep them all in operational readiness.

Broadly speaking we can classify the physical facilities into three categories:

- Space and seating arrangements
 - TV sets, antenna and other accessories
 - Literature
- (a) In each TV viewing school suitable space area must be earmarked for television viewing depending upon the number of viewers. Ideally speaking each class that has to view a TV lesson, should have a TV set, fitted in the classroom itself but this is not possible. Therefore, provision of a room, which can be converted into a TV room should be made. Hall is another alternative for large number of viewers. Other points to be taken care of are:
- Placement of TV set and its adjustment
 - Seating arrangement
 - Lighting
 - Ventilation
 - Space for demonstration, pre-telecast and post-telecast activities
- (b) It is needless to say that the TV sets should always be in operational condition so that these can be switched on at a very short notice. The various factors that put operating off are:
- Defective power points and plugs
 - Defective antenna
 - Maladjustment of TV controls

NOTES

- Major defect in the TV
- Voltage fluctuations
- Operational procedures like locked cupboards etc.

(c) The school television programmes by and large are syllabus-based programmes and therefore the students must know the connecting links between their classroom teaching and the television programmes. These should reach the classroom teacher in the beginning of the session or term as the case may be.

Films

Broadly speaking, a film is a multiple media of communication. It presents facts in a realistic way, dramatizes human relations, arouses emotions and transmits attitudes. It may be used for the communication of ideas, attitudes and experiences to the masses of people. It is very effective in adult education. An educational film has been described as the greatest teacher because it teaches not only through the brain but through the whole body. It has a very powerful influence on the minds of children and in shaping their personality. The main aim of educational films is to elevate and educate them according to the patterns and principles set by the society. A good educational film should help the students to develop a sense of citizenship. A film on national integration can be prepared to help inculcate ideas of oneness and unity. 'Live and Let Live' can be the theme. A variety of topics—historical, biographical and of current interest can be covered.

Advantages of motion pictures

Some of the main advantages of motion pictures are given below:

- **Increased reading interests of the students:** Various investigations conducted in USA show that film producers arouse increased reading interest in children. They are stimulated to get more information about the fact they have observed in a film show.
- **Real learning situations:** The film puts before us the learning situations which look to be quite real and actual. The child sees something happening and his experience is direct. Therefore, he is deeply impressed.
- **Selected learning situations:** A child learns from his actual life experience more than he learns from the lessons which he gets passively in the school. But life experience comes as a routine. Sometimes it has no educative value. Sometimes, it may have an adverse influence. But in an educational film, all the learning situations are the selected ones. They have a great educational value.
- **Quickness of movement:** The events in a film show run very swiftly but without losing continuity and essence of development. Therefore, the effects are also received swiftly in a concentrated form.
- **Vividness:** The learning situation is quite vivid. Everything is happening in such a way as if it is more than living and actual. All the activities are quite vivid.

- **Motivation:** The film motivates teaching. The child takes a great interest. A long study of many weeks may not be able to bring home the facts of the French Revolution to a child but he will at once understand and learn everything about the movement if he is shown a film of the events.
- **Recreation:** A film show is recreational as well. Thus, he learns through play. He feels light and happy after the show.
- **Development of study habits:** Educational films develop study habits as children like to know more about the facts they have learnt in the show.
- **Illustration of all learning situations:** We cannot give an adequate idea of an ocean to a child who has never seen even a lake. A child cannot understand what a mountain is like if he has never come across a hill in his life. But it is not possible for us to take every child to the ocean and mountains, to the deserts and valleys, to the Tundra's and the Tropics. The film serves us here wonderfully. It brings the ocean, the mountains, the deserts, the valleys, the Tundra's and the Tropics, all in their form and with all their grandeur into the school hall.

Charles F. Hoban and E. B. Ormer summarize the educational advantages of films as: means of imparting information, development of skills, development of attitudes, enlarging interests and development of the will to solve problems.

Disadvantages

Some of the main disadvantages of motion pictures are given below:

- Educational films sometimes include an element of fiction in historical events.
- Recapitulation is not possible on the spot. Sometimes the teacher likes and the pupils too wish to dwell longer on a particular shot in the show. But the film does not wait; it goes on.
- Really good educational films are not available in our country.
- The whole process is very costly. All the schools cannot afford to have good halls, projectors and other equipment for the purpose.
- It may have some bad effect on eyesight.
- Generally teachers are not trained in handling the projectors and organizing shows.
- It needs electricity. Many village schools have no electricity.

Suggestions for making the optimum use of educational films

The most important point to be taken into consideration is that the film must be relevant and purposeful.

When a film show is going to be arranged, the teacher should see that it is really needed in connection with the topic which is being taught. He must discuss the background of the learning situations to be presented in the film show, prior to the presentation. It should serve the purpose of recapitulation. The whole process may be arranged in the following steps:

NOTES

- Preliminary talk about the film
- Presentation of the film
- Discussion and follow-up on the film
- Recapitulation and recording of salient features

NOTES

Children's Film Society

The Children's Film Society India (CFSI) was established in 1955 as an autonomous body with the objectives of promoting and encouraging the Children Film Movement in the country. It also aims at providing children and the young people, films with clean and healthy entertainment. The organization is engaged in production, acquisition, distribution and exhibition of the films suitable for the children and young people. The main office of the society is in Mumbai and zonal offices are in New Delhi, Chennai and Kolkata. Since its inception, the society has produced and purchased about 100 feature films and 104 short films.

A pilot project to reach the rural children in Maharashtra by means of Mobile Film Unit has been in operation for a number of years. Four children film clubs are functioning, viz., one in Kolhapur (Maharashtra), two in Porbandar (Gujarat) and one in Mumbai.

The society organizes film festivals and participates in important international film festivals abroad. In India, the first international film festival was organized in Bombay in 1979. In 1981, the Indian festival was accorded 'A' category status by the International Centre of Films for Children and Young People (ICFCYP), Paris. The society has set up a National Centre of Films for Children affiliated to the International Centre of Films set up at Brussels under the sponsorship of UNESCO. Some of the important films that a teacher can make use of are: (1) *Scout Camp* (2) *Guru Bhakti* (3) *Ganga Ki Lahren* (4) *Bachon se Batten* (5) *Gulab Ka Phool* (6) *Ekata* (7) *26 January*.

Press as medium of education

The press is an informal but a very influential agency of education. The press includes newspapers and magazines. They provide a variety of information. They cover almost all areas of knowledge. They keep us well-informed. They are very useful in the teaching of various subjects. Instruction through newspapers introduces variety and an element of 'play-way'.

The newspapers are very useful for the study of languages. Pupils learn many new words and many new expressions. They learn how to express themselves and how to follow the expression of others. As regards social studies they learn how the society is developing day by day. They learn a lot about the society. There is much geographical and scientific information available in daily papers and magazines.

For international understanding the study of newspapers is essential. Children come to know how the world is progressing, how we are woven internationally, how the events occurring in one country affect all the other countries of the world and how we shall have to suffer if a third world war breaks out.

CHECK YOUR PROGRESS

11. State the significance of audio-visual aids.
12. What are models?
13. List two demerits of the radio's school broadcast programmes.
14. When and why was the Children's Film Society established?

NOTES

1.8 ROLE AND SIGNIFICANCE OF EDUCATIONAL TECHNOLOGY

The impact of extraordinary developments in the field of information and communication technology (ICT) has been the strongest on education. The advent of the new millennium brought with it the awareness of being part of one of the most spectacular revolutions of technology. This revolution of technology is most focused on the areas of information technology, communication and multimedia. In general, it signifies the start of an information society and therefore, plays a key role in attributing education to every aspect of life. The purpose of educational technology is also to promote the efficiency of education by improving the quality of teaching, of educational administration, and of educational research. Some examples of significant developments in this direction are given below.

- **Wider participation:** Technology has made it feasible for education to reach across to wider audience. This is especially relevant for the Indian setup, where the limitations of geographical, economic, physical and social nature exist. The expansion of distance education at both, school and higher education levels has helped in increasing the educational status of the country. Educational technology has assumed an important role in expanding the services of open education through institutes like, National Institute of Open Schooling (NIOS) and Indira Gandhi National Open University (IGNOU) among others.
- **Empowerment of learners:** In traditional terms, a learner takes up a course through a schedule of classes that are conducted at fixed venues, on fixed days. The teacher or coordinator decides the speed and frequency of the classes. The students' requirements and mental levels are assumed by the teacher. Nevertheless, different learners have different capacities of grasping. Every person is not adapted to typical classroom sessions. Learning can be transmitted in a number of ways by the use of technology. There are some learners who find reading convenient and others who prefer audio-visual presentations, group discussions and other interactive means. Technology offers learners the choice to access course material through different media, depending on their preferences. Technology can deliver learning in a way that is most suitable for the individual such that every learner can enjoy a unique learning experience.

NOTES

- **Facilitate application of senses, memory and cognition:** Learning needs to be understood as a technique to demonstrate ability. This is in consonance with Bloom's Taxonomy, in which a blend of mind and body summarizes the outcome of learning. However, the wants of human abilities are not sufficiently fulfilled by modern teaching and learning conditions. This process is facilitated by technology, for example, a learner can understand the universe through video facilities, or make use of the Internet to learn about that which is beyond his physical reach.
- **Differentiated instruction:** Educational technology calls for active participation of students to use different strategies of questioning. It makes individual instructions more generic and propels the growth of personal learning strategies. There is ample motivation for learners to use different aspects of multimedia and make creative use of the knowledge gained by them.
- **Enhance teaching practices:** In the formal system of education, learning can never happen in isolation. This means that only by making information and resources accessible to learners, we cannot consider the job as done. Practically, our system of education runs on the belief that the progress of the learner will be quicker when he/she is guided by a teacher (skilled instructor). Educational technology assists and supports teachers in the teaching-learning process.
- **Improve learning outcomes:** Technology, newer methods, incentives, policies; everything planned for education would be a waste if the learning outcomes are not improved. If new technology fails to bring about betterments, then its use should be discontinued. Hence, educational technology has been continuously trying out and exploring newer technologies: intelligent classrooms, podcasts, Internet, and laptops. These efforts are directed at making gradual changes in techniques and removal of defects. Educational technology has thus enabled the teachers to improve learning outcomes.
- **Continuing education (lifelong education):** The rapid explosion of knowledge has made it necessary for an individual to learn throughout his life. Continuing education (*Nirantar Shiksha*) is absolutely necessary for improving the quality of one's life. This has been made possible only through use of educational technology.
- **Multiple learning resources:** Traditional teaching conditions had limited learning resources, but technological revolution has made it possible to present multiple learning resources to the learners easily. Now, we find that a computer not only presents visuals but also speaks to the learner. We also come across many innovations in the field of telecommunications.
- **Rapid adaptability of learning resources to learner's needs:** Generally, learning resources available to learners were mostly impersonal (e.g., a static textbook). These do not change according to the needs of a learner, at different stages of learning. The changes in computer-linked learning resources, as well as methods emerging out of new cognitive psychology and group dynamics stream facilitate learning in different abilities. More and more integrated

innovations in educational technology are taking place, and designers of the instructional system are rapidly incorporating newer developments in the field. Programmed learning and personalized system of instruction are examples of the same.

- **Solving the problems systematically:** Educational technology is a continuous and comprehensive programme, providing a scientific basis to the education system. It can work to remove intrinsic shortcomings of the system. This can be done by use of demonstrations that are regularly broadcasted, or through documents designed for pupils. Educational technology can make the operation of schools slightly flexible. Nevertheless, it cannot be considered as a miraculous solution for all problems in the educational system.
- **Professional development of teachers:** Educational technology offers a number of possibilities for continued professional development of teachers. In the changing scenario, the teacher cannot suffice with the pre-service education that he/she has received. They need to continuously update themselves with newer information and methods available. Educational technology in its different forms has enabled teachers by providing them with options like distance education, e-learning, online learning and other similar forms of alternative education.
- **Communication and support:** Communication is the backbone of any form of teaching–learning situation. Educational technology has proposed several systems of communication for both formal and non-formal learning situations.
- **For preservation of knowledge:** Modern electronic gadgets provide tremendous capabilities to preserve knowledge/information for future use, including print media. Information can be preserved in the form of audio-video programmes, computer software, videodiscs, and retrieved when required. Thus, bulk of the information can be preserved electromechanically, for instance, a videodisc is capable of preserving a complete set of encyclopaedia.
- **For transmission of knowledge:** Use of modern media in education can reach and teach students in any part of the globe. Radio and television broadcasts can reach large number of students in different parts of the country. Almost the entire country can be covered simultaneously through radio or television networking systems. Communication satellites have added to the effectiveness and efficacy of communication at a distance, and made it possible to link more than one location and more than one group of students through two-way talkback system.
- **Optimum use of resources:** The idea behind educational technology is not maximization of resources but appropriate use of the resources available. It should be understood that educational technology is not an end in itself but a means to accomplish some educational and instructional objectives, already determined and clearly defined. The objective is to make the whole teaching–learning process more meaningful and effective for both learners and teachers.
- **Future prospects in education sector:** Career has become a priority for students nowadays. For the development of their career, substitute means of

NOTES

education such as distance and open learning, education on demand and other such flexible models are necessary. This again emphasizes the role of educational technology in the teaching–learning process.

NOTES

Educational technology is enabling multi-modal teaching, changing curricula and spawning rich forms of online research and collaboration. Exceptional prospects of growth have been created by continuous advancements in educational technology. This has deeply impacted the teaching capacity of teachers and the learning capacity of learners. To develop a new learning culture, it is imperative for teachers to gain expertise in Information & Communication Technology (ICT) skills and their utilization. The amalgamation of technology should be driven by effective learning. This makes it necessary to be in synchronization with technological developments to build practicable solutions. Although, the availability of tools is in abundance, the ability to use them for improving the learning experience should be clear.

Moreover, when educational technology develops, it will give rise to the prospect of creating and recreating new types of educational institutions in future. It would help in reducing wastage of both physical resources and human resources to a minimum (Mohanty, 2006). Further, educational technology has value only to the extent that it actively assists learners in obtaining knowledge and skills, as has been said in the *Encyclopaedia of Education*. The *Encyclopaedia of Education* also mentions: ‘Whether any particular device is functionally more efficient than any other will depend primarily upon whether the device is compatible with the dynamics of the learning process, the prior experience of the learner with the body of materials to be presented and the learners’ physical, attitudinal and motivational preconditioning for use of hardware, software and the particular response mode of the equipment’.

In essence it can be said that educational technology can contribute to qualitative as well as quantitative improvement of education. There is a silver line to this aspect as observed by the International Commission on Education (1973), ‘Educational technology is not just an apparatus to be clamped on to a conventional system, to add or multiply traditional procedures. It can only be of value if it is really integrated into the entire system and if it leads us to rethink and renovate it’.

Schools still need to go a long way in exploring the depth of educational technology. Educators now view technology as a means to explore and create. Even students, who are not doing well, can improve and succeed with the help of educational technology. It develops self-esteem and transforms the reluctance to learn into motivation. Students are empowered through multiple and convenient means of learning and a learning environment that is psychologically stable (Wesley, 2004).

CHECK YOUR PROGRESS

15. State the purpose of educational technology.
16. What are the ways in which educational technology has helped in the continual professional development of teachers?
17. How does the use of modern media help students?

1.9 SUMMARY

- History has revealed that technology strengthens the hands of a teacher and makes his/her teaching more effective. Education has been benefited by technology in various ways and at various levels.
- The 21st century has been named as ‘age of knowledge’ and there is no way in which one can deny the role of technology in different aspects of our lives. Like other fields, education too has been deeply impacted by technological revolution. This interface of education and technology is popularly known as educational technology.
- Educational technology is the use of those audio-visual devices in training, which are based on modern technology, e.g., use of computer stimulators, television, radio, video-tape, etc.
- The roots of educational technology lead us to the time when early tools had come to exist, e.g., paintings on cave walls.
- Educational technology has the following prime objectives:
 - o To modernize learning methods and techniques according to the changing world
 - o To bring desirable changes in the behaviour of teachers and pupils by improving teaching, learning and evaluation conditions
 - o To make classroom teaching clear, effective, objective and scientific
- ‘Technology in education’ refers to the use of technological hardware in education. Here, more importance is given to the media used for carrying a message.
- Professor Henry Ellington (1993) opined that the key function of educational technology is to bring about improvements in the general competence and efficacy of the teaching–learning process.
- Educational technology performs the twin functions of a tool and a catalyst. The three commonly accepted types of educational technologies are: (i) teaching technology, (ii) behavioural technology and (iii) instructional technology.
- Teaching technology is that form of educational technology, which is concerned with making the process of teaching more systematic.
- Behavioural technology is a vital constituent of educational technology. It emphasizes that psychosomatic values be used in learning and teaching. The motive is to change the behaviour of the teachers and pupils to match with the objectives of teaching.
- The hardware approach implies the use of mechanical materials and equipment in the domain of education.
- The software approach or software technology of education owes its origin to behavioural sciences and their applied aspects concerned with the psychology of learning.

NOTES

NOTES

- Systems analysis or approach is a term used to describe the systematic application of educational technology to an educational or training problem starting with the input (entry behaviour) and output (terminal behaviour) and determining how best to progress from the former to the latter.
- Media includes such things as prints, graphics, photography, audio-communication, television, simulating games and computer.
- Audio-visual aids or devices or technological media or learning devices are additional devices that help the teacher to clarify, establish, co-relate and co-ordinate accurate concepts, interpretations and appreciations and enable him to make learning more concrete, effective, interesting, inspirational, meaningful and vivid.
- The epidiascope is an instrument which can project images or printed matter or small opaque objects on a screen.
- Three dimensional aids serve as good substitutes for the real objects. Models diagrams, mock-ups and specimens are the important three dimensional aids.
- A film is a multiple media of communication. It presents facts in a realistic way, dramatizes human relations, arouses emotions and transmits attitudes. It may be used for the communication of ideas, attitudes and experiences to the masses of people.
- The Children's Film Society India (CFSI) was established in 1955 as an autonomous body with the objectives of promoting and encouraging the Children Film Movement in the country. It also aims at providing children and the young people, films with clean and healthy entertainment.
- The impact of extraordinary developments in the field of information and communication technology (ICT) has been the strongest on education. The advent of the new millennium brought with it the awareness of being part of one of the most spectacular revolution of technology.
- In the changing scenario, the teacher cannot suffice with the pre-service education that he/she has received. They need to continuously update themselves with newer information and methods available. Educational technology in its different forms has enabled teachers by providing them with options like distance education, e-learning, online learning and other similar forms of alternative education.
- Use of modern media in education can reach and teach students in any part of the globe. Radio and television broadcasts can reach large number of students in different parts of the country.

1.1 KEY TERMS

- **Educational technology:** The application of scientific knowledge and learning and the conditions of learning, to improve the effectiveness and efficiency of teaching and training is termed as educational technology.

- **Technology in education:** ‘Technology in education’ refers to the use of technological hardware in education. Here, more importance is given to the media used for carrying a message.
- **Technology of education:** ‘Technology of education’ can be referred to as a purposeful utilization, in combination or separately, of objects, techniques, devices, events and relationships to increase the effectiveness of educational purpose.
- **Behavioural technology:** Behavioural technology is a vital constituent of educational technology. It emphasizes that psychosomatic values be used in learning and teaching.
- **Instructional technology:** The application of modern skills and techniques to requirements of education and training (instruction). This includes the facilitation of learning by manipulation of media and methods and the control of environment’.
- **Systems analysis/approach:** Systems analysis or approach is a term used to describe the systematic application of educational technology to an educational or training problem starting with the input (entry behaviour) and output (terminal behaviour) and determining how best to progress from the former to the latter.
- **Gestalt psychology:** Gestalt psychology or gestaltism (German: **Gestalt** [aYÈftalt] ‘shape, form’) is a theory of mind of the Berlin School. **Gestalt** psychology tries to understand the laws of our ability to acquire and maintain meaningful perceptions in an apparently chaotic world.
- **Audio-visual aids:** Audio-visual aids are those sensory objects which initiate or stimulate learning.
- **Chart:** A chart is a combination of pictorial, graphic, numerical or vertical material which presents a clear visual summary.
- **Epidiascope:** The epidiascope is an instrument which can project images or printed matter or small opaque objects on a screen.
- **Graphs:** Graphs are flat pictures which employ dots, lines or pictures to visualize numerical and statistical data to show relationships or statistics.
- **Micro-projector:** The combination of a microscope and a slide projector is an instrument called micro-projector.
- **Overhead projector:** Overhead projector is a device that can project a chart, a diagram, a map, a table or for that matter, anything written on transparent plates, upon a screen or the white wall before students in a class.

NOTES

1.11 ANSWERS TO ‘CHECK YOUR PROGRESS’

1. Like other fields, the field of education too has been deeply impacted by technological revolution. This interface of education and technology is popularly known as educational technology.

NOTES

2. The meaning of educational planning technology focuses on planning at the supra-institutional or national level. Non-educators are the prime occupants of this field.
3. Hilliard Jason has given the following points on the objectives of educational technology:
 - It transmits information
 - It serves as a role model
 - It contributes to the provision of feedback
 - It assists in the practice of specific skills
4. 'Technology in education' refers to the use of technological hardware in education. Here, more importance is given to the media used for carrying a message.
5. The three commonly accepted types of educational technologies are: (i) teaching technology, (ii) behavioural technology and (iii) instructional technology.
6. Behavioural technology is a vital constituent of educational technology. It emphasizes that psychosomatic values be used in learning and teaching. The motive is to change the behaviour of the teachers and pupils to match with the objectives of teaching.
7. The hardware approach implies the use of mechanical materials and equipment in the domain of education. Audio-visual aids like charts, models, filmstrips, slides, audio cassettes and sophisticated equipment and gadgets like films, projectors, radio, tape recorder, record player, television, video, teaching machines, computers, etc., fall in the category of hardware.
8. Characteristics of hardware are as follows:
 - Hardware components are generally electronic and mostly depend on mechanical systems.
 - New techniques and researches are being conducted to evaluate the effect of hardware.
 - The outcome of hardware is direct and immediate because of its concrete form.
 - Hardware components are the media of communication.
9. Systems analysis or approach is a term used to describe the systematic application of educational technology to an educational or training problem starting with the input (entry behaviour) and output (terminal behaviour) and determining how best to progress from the former to the latter.
10. Systems approach as applied to education is a rational problem solving method of analysing the educational process taken as a whole, incorporating all of its parts and aspects, including the students and teachers, the curriculum content, the instructional materials, the instructional strategy, the physical environment and the evaluation of instructional objectives.

11. Audio-visual aids or devices or technological media or learning devices are additional devices that help the teacher to clarify, establish, co-relate and co-ordinate accurate concepts, interpretations and appreciations and enable him to make learning more concrete, effective, interesting, inspirational, meaningful and vivid.
12. Models are substitutes for real things. A model is a three-dimensional representation of a real thing. Models are concrete objects to explain clearly the structure or functions of real things. A model is a replica of the original. Models enable students to have a correct concept of the object.
13. The demerits of the radio's school broadcast programmes are:
 - Radio broadcast is a one-way communication. Students cannot put questions to the broadcaster.
 - The educational value of radio broadcasting depends merely on the use of sense of hearing.
14. The Children's Film Society India (CFSI) was established in 1955 as an autonomous body with the objectives of promoting and encouraging the Children Film Movement in the country.
15. The purpose of educational technology is to promote the efficiency of education by improving the quality of teaching, of educational administration, and of educational research.
16. Educational technology offers a number of possibilities for continued professional development of teachers. In the changing scenario, the teacher cannot suffice with the pre-service education that he/she has received. They need to continuously update themselves with newer information and methods available. Educational technology in its different forms has enabled teachers by providing them with options like distance education, e-learning, online learning and other similar forms of alternative education.
17. Use of modern media in education can reach and teach students in any part of the globe. Radio and television broadcasts can reach large number of students in different parts of the country. Communication satellites have added to the effectiveness and efficacy of communication at a distance, and made it possible to link more than one location and more than one group of students through two-way talkback system.

NOTES

1.12 QUESTIONS AND EXERCISES

Short-Answer Questions

1. What according to *Shiksha Paribhasha Kosh* is educational technology?
2. List the characteristics of educational technology.
3. Enumerate the prime objectives of educational technology.

NOTES

4. Differentiate between 'technology in education' and 'technology of education'.
5. What are the assumptions on which teaching technology is based?
6. List the characteristics of teaching technology.
7. What are the features of instructional technology?
8. What are the components of educational technology?
9. Write a note on the hardware approach as given by Lumsdaine.
10. What is the contribution of hardware and software in the field of education?
11. State the reason why schools have developed the systems analysis.
12. Enumerate the advantages of systems approach.
13. What are audio-visual aids?
14. What are the characteristics of good teaching aids?
15. What are the problems in the use of teaching aids?
16. Write short notes on (a) epidiascope (b) film strip (c) graphs.
17. Identify the various aspects of maps.
18. What do you understand by three dimensional aids?
19. What is the significance of educational television?
20. How does educational technology help in solving the problems systematically?

Long-Answer Questions

1. Discuss the concept of educational technology.
2. 'The roots of educational technology lead us to the time when early tools had come to exist, e.g., paintings on cave walls.' Explain the nature of educational technology with reference to the given statement.
3. Assess the different types of educational technology. Also differentiate between the three types of educational technology.
4. Critically analyse the components of educational technology.
5. Explain the contribution of the systems approach in the field of education.
6. Elaborate the advantages of audio-visual aids. Describe the use of blackboards in the teaching-learning process.
7. Identify the different types of charts. Also mention the uses of charts.
8. What are the merits and demerits of radio school broadcasting programmes?
9. Describe the role of the teacher in school television programmes.
10. Evaluate the role and significance of educational technology.

1.13 FURTHER READING

- Aggarwal, J. C. 2009. *Essentials of Educational Technology*. New Delhi: Vikas Publishing House.
- Kochhar, S. K. 1985. *Methods and Techniques of Teaching*. New Delhi: Sterling Publishers.
- Mangal, S. K. 2001. *Foundation of Educational Technology*. Ludhiana: Tendon Publications.
- Sampath, K., A. Panneerselvam, S. Santhanam. 2007. *Introduction to Educational Technology*. New Delhi: Sterling Publishers.
- Shankala, D.P. 2006. *Educational Technology*. New Delhi: Adhyayan Publishers and Distributors.
- Sharma, K. K. 2007. *Educational Technology*. Delhi: Mahaveer & Sons Publishers and Distributors.
- Sharma, R. A. 2002. *Technology of Teaching*. Meerut: International Publishing House.

NOTES

UNIT 2 COMMUNICATION

Structure

- 2.0 Introduction
- 2.1 Unit Objectives
- 2.2 Communication
 - 2.2.1 Communication Cycle
 - 2.2.2 Principles of Communication
- 2.3 Classroom Communication
 - 2.3.1 Verbal Communication
 - 2.3.2 Non-verbal Communication
- 2.4 Factors Affecting Classroom Communication
 - 2.4.1 Barriers to Effective Classroom Communication
 - 2.4.2 Guidelines for Better Communication in Classrooms
- 2.5 Observation Schedules of Classroom Interaction
 - 2.5.1 Importance of Observation
- 2.6 Flanders' Interaction Analysis Categories System (FIACS)
 - 2.6.1 Basic Theoretical Assumptions of Interaction Analysis
 - 2.6.2 Categories of Flanders' Interaction Analysis
 - 2.6.3 Observation of Classroom Events
 - 2.6.4 Construction of Interaction Matrix
 - 2.6.5 Interpretation of Interaction Matrix
 - 2.6.6 Advantages of Flanders' Interaction Analysis
 - 2.6.7 Disadvantages of Flanders' Interaction Analysis
- 2.7 Teaching
 - 2.7.1 Variables of Teaching
 - 2.7.2 Phases of Teaching
- 2.8 Teaching Machine
 - 2.8.1 History of Development of Teaching Machine
 - 2.8.2 Characteristics of Teaching Machine
 - 2.8.3 Constituent Parts of Teaching Machines
 - 2.8.4 Types of Teaching Machines
 - 2.8.5 Advantages and Disadvantages of Teaching Machines
- 2.9 Summary
- 2.10 Key Terms
- 2.11 Answers to 'Check your Progress'
- 2.12 Questions and Exercises
- 2.13 Further Reading

NOTES

2.0 INTRODUCTION

In the modern world of science and technology where man is advancing with time, we cannot deny the fact that our education system is also being affected. However, the success of education cannot be achieved merely by replacing human beings with technologies. It needs a right blend of both labour and scientific inventions. We have to utilize the existing resources to improve the way we communicate with each other. To make the process of teaching–learning more effective, communication, as

NOTES

the most important tool, should be used in a proper way. The teacher should communicate facts, skills, ideas and attitude. However, it has been found that there are some principles of communication which may help in improving the relationship between teachers and students.

Communication is a powerful means of bringing about social change. The revolution in media has helped in accelerating the pace of social change during the last few decades. Teaching will only be effective if its outcome is positive. As we know all students are not the same, additional material should be available to help each one of them. Skinner developed one such implement known as 'teaching machine'. It is very helpful in the activity of memorization. In this unit, you will be acquainted with the concept of communication, types of classroom communication, factors affecting classroom communication, the observation schedules of classroom interaction, Flanders' Interaction Analysis, the process of teaching and the teaching machine as a tool for enhancing the process of teaching.

2.1 UNIT OBJECTIVES

After going through this unit, you will be able to:

- Discuss the concept and significance of communication
- Explain the types of classroom communication in detail
- Assess the factors affecting classroom communication
- Critically analyse the observation schedules of classroom interaction
- Evaluate the Flanders' Interaction Analysis as a tool for enhancing the teacher-learning process
- Critically analyse the process of teaching, its variables and phases
- Discuss the teaching machine as a tool for enhancing the process of teaching

2.2 COMMUNICATION

Man is a social animal and his ability to communicate is the prime factor that distinguishes him from other animals. Apart from basic necessities, one needs to be equipped with good communication skills. We always want to share our thoughts, feelings, ideas and beliefs with other people around us. We can exchange information through words, gestures, signs and symbols, expressions; tone. One can also make use of technical media like telegraphy, radio, television, computer, for interaction. This interaction is called communication. Communication, derived from the Latin word '*communicare*' which means 'to share', is the process of transmitting information and understanding. Communication is a complex and ongoing process. It is a process of exchanging verbal and non-verbal messages. The way we communicate is a learned style. We grow up watching our parents and other people communicate with each other. As adults, we can learn improved ways of communication by observing others who communicate effectively, learning

new skills and practising those skills. The ability to effectively communicate at work, home and in life is probably one of the most important sets of skills a person needs. In the process of teaching–learning, communication plays a very important role. If a teacher is a good communicator, only then will he/she be able to interact with students properly to make them understand his/her ideas or thoughts. Any idea or thought which is not shared is of no use. Hence, communication is a must as it involves transmission of message by a sender and its proper understanding by the receiver.

NOTES

Definitions of Communication

Some of the important definitions of the process of communication are as follows:

- W.H. Newman and C.F. Summer defined communication as, ‘an exchange of facts, ideas, opinions or emotions between two or more persons’.
- According to John Hoben, ‘communication is the verbal interchange of thoughts or ideas’.
- According to Martin Anderson, ‘communication is the process, by which we understand others and in turn, endeavour to be understood by them. It is dynamic, constantly changing and shifting in response to the total situation’.
- According to Claude Shannon and Warren Weaver, ‘communication involves all the procedures by which one mind may affect another. This involves not only written and oral speech, but also music, the pictorial arts, the theatre, the ballet, and in fact all human behaviour’.
- According to Merrihus, ‘communication is a process of mutual exchange of thoughts, ideas, facts and emotions’.
- According to John Dewey, ‘communication is a process of sharing experiences till it becomes a common possession’.

Characteristics of Communication

Communication has some basic characteristics, which are discussed as follows:

- **Purposeful:** Communication always involves a purpose. Whenever an idea or thought arises in the mind of a sender, he wants to communicate it. This means there is always some purpose behind it. The purpose of communication is to impact attitudes and behaviour of those involved.
- **Universal:** Communication is the only way through which human beings can share information. Thus, communication is a universal process as it occurs almost everywhere.
- **Interactive:** Interaction is the primary characteristic of communication in which two or more persons or groups interact with each other. It may result in social interaction. Thus, it is a two-way dynamic flow of information.
- **Imperfect:** A perfect communication is never possible in reality because what a person thinks can never be exactly understood by the receiver. This is because every individual is different from the other and perfect synchronization of minds is never possible.

NOTES

- **Dependent:** Communication is performed with the help of some kind of media. Communication is now carried out through various channels or modes, ranging from sophisticated communication media and technology, to non-verbal signals. So, it is dependent on some kind of media through which message from one person could be sent to another.
- **Complex:** Communication is a complex process which involves various steps. A number of barriers can hinder this process at both ends (sender and receiver).
- **Contextual:** Communication always takes place within a context. The context of communication has at least four dimensions: (i) physical, (ii) social, (iii) psychological and (iv) temporal. These dimensions interact and influence, and are influenced by one another.

Importance of Communication

As we have already discussed, communication is nothing but the transmission and understanding of message from sender to receiver. It is a very important aspect of human life because it is only through communication that human beings can interact with each other as individuals and as independent groups. It is an essential and basic process in all fields of life. Communication skills can be used virtually in every field. Effective communication is important because it allows people to lead more satisfying lives. Some other reasons that explain why communication is important are as follows:

- **Transmission of information:** Communication is a must to transfer information between individuals and places. Any message which is not communicated is of no use.
- **Displaying ideas/emotions:** Whether it is in written or oral form, we always express ourselves by communicating with others. Without communication, we are not able to express our feeling or ideas. Hence, communication is important to transmit emotions/ideas.
- **Education:** The whole process of education involves imparting of knowledge to students by the teacher. However, this knowledge is imparted by various media which depend on communication. Education without communication is impossible.
- **In building relationships:** Communication plays a vital role in building relationships between people. It facilitates dialogue, exchange of expression and emotions which result in relationships. The type of communication decides the relation. It could be personal or professional.
- **Entertainment:** To break away from the daily schedule of life full of stress, entertainment is a crucial part of everyone's life. Nowadays, every source of entertainment like movies, music, television shows, games, theatre or even anecdotes narrated by people involve communication.
- **Achievement of goals:** The ability and the importance of communication become much more crucial when we are on a mission, or need to achieve a goal. Without a means to communicate, an organization will become isolated.

The ability to effectively communicate is very important to achieve the set goals.

- **Cultural promotion:** Communication offers a prospect to promote and preserve culture and traditions. It helps people in fulfilling their desire to be creative.
- **Integration:** It is with the help of communication that many people in a large number of countries all over the world, gain awareness related to each other's customs and tend to admire each other's lifestyle and culture. It progresses the activity of being integrated and tolerant with respect to each other.
- **Discussion:** The processes of debating and discussing elucidate various perspectives on matters that are of interest to people. With the help of communication, the reasons for difference in opinions and imparting of new ideas to others can be pinpointed.

NOTES

2.2.1 Communication Cycle

The process of communication consists of a message being sent and received (Figure 2.1). The effectiveness of communication can be estimated by the similarity between the message sent and the one received.

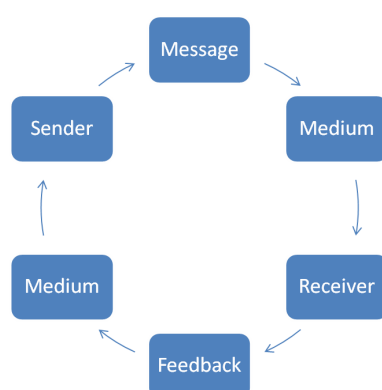

Fig. 2.1 Communication Cycle

Thus, it is a two-way process in which information is sent by one person and received by the other. It is a continuous process in which different steps are followed for proper understanding and effective communication. The process of communication can be explained with the help of a communication cycle, which involves the following:

- **Sender of the message:** Initiation of the process of communication is done by a sender or communicator who conceptualizes the idea that is to be transmitted. A sender is a person who initiates communication by making use of language or symbols to convey the message. The views, advancement, ability, mind-set, capability and awareness of the sender have a great impact on the message. It is also very important to choose correct symbols, depending on the audience and the environment. It is essential to select appropriate spoken and written symbols to ensure that the message is interpreted correctly by the receiver.

NOTES

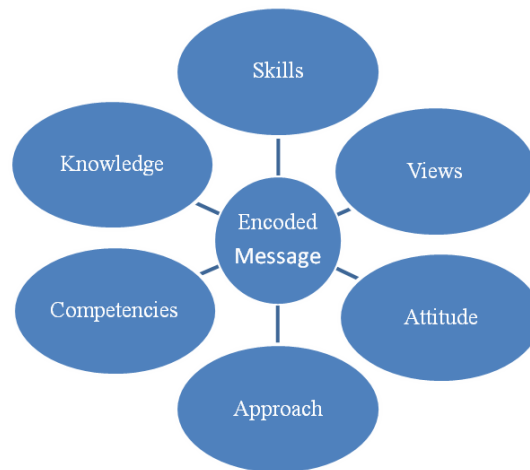

Fig. 2.2 Conditions Affecting a Message

- **Message:** The process of communication begins with the finalization of the message to be conveyed. Message is a key idea, thought, opinion, feeling, knowledge or information, that a sender wants to communicate. A message is sent by the source and received by the destination. It is encoded in a way that can be understood by both the sender and the receiver. A message can be written or oral. It may be well-organized and structured, or unorganized and unstructured depending upon the nature of the communication. Anything which conveys thoughts or feelings can be considered a message, for example, a painter communicates through his paintings, a writer communicates with the help of his writings, a dumb person communicates through symbols or movement of fingers, an actor can convey his message through expressions. All these examples can be considered as messages.
- **Channels of communication:** In order to convey what the information means to the receiver, the sender uses the process of encoding. In encoding, information is translated into a format which can be understood by the receiver. Information is either oral, written or visual. The medium or means which a sender employs to convey his message is known as ‘channel of communication’. Through this channel, the sender is connected to the receiver. The majority of channels transfer information in either verbal or written format. However at present, visual channels are gaining popularity due to the expansion of technology. Some common official channels of communication are: letter, memorandum, e-mail, telephone, fax, telegram or television. Every channel has its own advantages and disadvantages. It is important to select a suitable channel for communicating effectively and for correct interpretation of the message by the receiver. For instance, written channels are more effective when the receiver of the message is a small group of people. Similarly, the effectiveness of oral channels is more when the receiver requires quick feedback. Some situations require the use of both written and verbal modes of communication. Thus, sender has to select the right kind of channel (Figure 2.3) for the message to reach the right receiver.

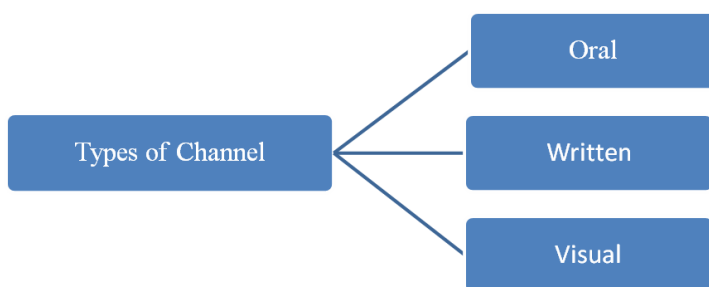

Fig. 2.3 Channels of Communication

NOTES

- **Receiver of the message:** Once the appropriate channel is selected, the decoding stage of the message begins. The process of interpretation of the information that is transferred is known as 'decoding'. Decoding is done by the receiver. The receiver interprets information that the sender sends. The receiver translates the message in order to make the symbols meaningful. A number of factors govern the extent to which a message is interpreted by the decoder. Some of these factors are: the receiver's knowledge, his sensitivity to the message, and the degree of dependence of the encoder on the decoder. Successful communication takes place when the receiver correctly interprets the sender's message.
- **Feedback:** The most important part of the communication process is the feedback. On the basis of this component, the sender analyses how effective the message is. If there is no feedback, the sender would not be able to make sure that the message has been interpreted by the receiver. There would be no way of knowing if meaning had been shared. Once the message is received by the receiver, he sends a response to the sender. The signal might probably be a spoken comment, a written message, a smile, or any other similar activity. Hence, one can assume that feedback may be in the form of words, or in the form of smiles, and sighs.

2.2.2 Principles of Communication

At the time of communicating, it is very important to consider some of the general principles of communication. These principles are the same for all human beings, no matter what ethnicity or culture they may be part of. These principles help to overcome all barriers of communication and make the process more successful. Thus, it is important to consider some of the general principles of communication to make the process more effective. Following are some important principles which should be kept in mind, during the process of communication:

- (i) **Principle of mastery on language:** Verbal communication is the most widely used form of communication. It uses language to express thoughts and ideas. Mastery of language is vital for effective communication. The sender or source of communication should use the language which is easy for the receiver to understand. In a classroom, the teacher should be fluent in the language which the students understand; only then it will be possible for the teacher to convey the message to students. Individuals without this mastery are prone

NOTES

to be misunderstood and their efforts to communicate their ideas may not be successful. Sometimes, a teacher is very good in his subject, but it is of no use if he is not able to communicate the knowledge to his students. Therefore, both the teacher and the students should have a good command on the language used to transfer knowledge in a classroom.

- (ii) **Principle of motivation:** The level of interest of both the source of communication and the receiver should be high throughout the process of communication. Lack of motivation, interest and zeal on part of the sender or the receiver may adversely influence the progress of communication. A teacher cannot teach the students until they are interested in the topic being taught. Hence, he needs to motivate the students for proper communication. The higher the level of motivation, the better the communication.
- (iii) **Principle of sharing and interaction:** During communication, it is important to be sensitive to the others and be aware of how the receiver is interpreting the message. The success of communication lies in sharing and mutual interaction between the sender and the receiver. A teacher should always involve the students while teaching to increase interaction and effectiveness of the teaching–learning process. Sharing of ideas and interaction between teacher and students is necessary to develop a relationship based on understanding and mutual experiences.
- (iv) **Principle of active listening:** Listening is an important aspect of communication and this role is played by the receiver of the message. To become an effective communicator, it is very important to listen to the other person. If the sender is not a good listener, it would be very difficult to understand what someone is trying to say. A lot of misunderstanding and misinterpretation can occur if there is lack of proper listening. Active listening ensures that the sender’s message is received both effectively and efficiently. A lot of misunderstanding and misinterpretation may be caused by not listening to the other person. A listener must be able to make sense out of what he hears, only then it will be called active listening. Although listening is not communication in itself, it is still an integral part of communication.
- (v) **Principle of suitability of communication contents:** The content which is to be communicated should have a definite purpose, cohesiveness and usefulness for the receiver. The content should be suitable and appropriate for both the sender and the receiver. The sender should be familiarized with the content to be communicated. On the receiver’s end, the content should be suitable enough to be grasped so that he can respond properly.
- (vi) **Principle of using appropriate channel:** Selection of the wrong communication channel can cause communication obstacles and inadequate feedback. Effective communication relies on selecting an appropriate communication channel for sending the message. While selecting the communication medium, one should keep in mind the purpose of the message.

More than one communication channel should be selected in order to reinforce information. For example, in a classroom it is always suggested to use various teaching aids, which may help students in better understanding of the topic being taught.

- (vii) **Principle of conducive environment:** A conducive environment is a very vital constituent for facilitating effective communication. The communication process should be protected from noise, disturbance, poor pronunciation, and improper ventilation, because in the presence of all these factors, communication may not be successful. Hence, to enhance the effectiveness of communication, a conducive atmosphere is necessary.
- (viii) **Principle of competency:** Competency is required at both the sender's and receiver's end in terms of communicating and receiving the desired information. Both of them should possess the communication skills which help the sender in sending the message and the receiver in receiving the message effectively. In a classroom, the teacher must be equipped with sufficient knowledge and skills to transfer information to the pupils.
- (ix) **Principle of appropriate body language:** Appropriate body language also plays a very important role in the communication process. One of the most influential modes of communication in day-to-day interaction is our body language, which includes eye contact, gestures, body stance and facial expressions. Individuals with improper body language are prone to be misunderstood and do not succeed in communicating their ideas. In a classroom, the teacher uses ample body language, but if it does not match with the words conveyed, the students may get confused and that will result in poor communication.
- (x) **Principle of appropriate feedback:** Appropriate feedback from receiving end conveys that the message of the sender has been received and interpreted correctly. The feedback can also work in reverse order from the source to the receiver's end. If a teacher gets proper feedback from the students, it will help him understand whether the communication is effective or not. In the same way, when students get feedback of their performance from the teacher, they get motivated and that results in better communication. In the absence of proper feedback, communication would be incomplete and improper.
- (xi) **Principle of using example:** The addition of examples always makes the message more interesting. For instance, various visual slides or other material related to the topic can result in better communication, especially in the classroom where the teacher has to deliver a lecture. The teacher may use a number of routine real-life examples so that his pupils understand the lesson better.
- (xii) **Principle of friendly nature:** Friendly attitude of sender can also help in receiving the message in a better way. Fear and threat of a senior or a more qualified person may make the receiver conscious and he may not interpret

NOTES

the message properly. For example, if a teacher is too strict, the students will not try to clear their doubts for fear of being punished. On the other hand, if the teacher is friendly, students feel comfortable in asking questions and even giving feedback.

NOTES

CHECK YOUR PROGRESS

1. State the derivative of the term 'communication' and its.
2. How is communication effective in building relationships between two individuals?
3. Define decoding.

2.3 CLASSROOM COMMUNICATION

Communication can be of two types—verbal and non-verbal communication. Both the types of communication has been discussed in the next section.

Let us study about verbal and non-verbal communication under this section.

2.3.1 Verbal Communication

Language is the key and the base of any verbal communication. Each society develops one or more forms of languages with spoken or written words for communicating with each other. Accordingly, we have local, regional, national and international language for the required communication. The basic units of any language are words and sentences which are governed by the rules of the grammar. Language can make use of one of the three forms: (i) oral, (ii) written (iii) oral and written. In the oral form, one can communicate one's feelings, thoughts and intentions to others by the speaking and listening channel. For this purpose, the sender/communicator makes use of some precise and distinct sounds which when heard by the receiver, are decoded for understanding their meaning.

In the written form of language communication, the communicator/sender makes use of the script of the language such as Assamese for Assamese language, Devanagari for Hindi and Gurumukhi for Punjabi. For the communication of thoughts and feelings, one writes about it through some written mode, pencil, paper or chalk, board or print media and the person at the receiving end understands the meaning of the communicated message through its reading and decoding.

In the usual classroom communication, a teacher while writing on the blackboard also makes use of language for the classroom communication, explanation and exposition of the written contents.

2.3.2 Non-Verbal Communication

The communication process can also be carried out without the use of any verbal means. In many cases, (such as communication with deaf and dumb, mentally

retarded, the persons not knowing the language of the sender or sending a secret message in the commonly coded and symbolic expression), it may become a necessity as well as compulsion to make use of the non-verbal communication. In normal situations also the non-verbal media is generally used for giving strength and effectiveness to the verbal communication. Components of non-verbal communication are discussed as follows:

- Proxemics: Study of space in interpersonal communication
- Chronemics: Study of time factor
- Paralanguage: Study of voice quality and variety
- Haptics: Study of touch
- Oculistics: Study of eyes
- Kinesics: Study of body language

You will now be able to comprehend the various elements of non-verbal communication given in brief in the following sections.

Proxemics

Proxemics is the study of perceptions of people on physical space and its use by them. Aggression is caused by power. Those who like to be powerful occupy larger space. Large office rooms, big cars, large tables and large quarters are high-status indicators.

Based on the concept of territory, Edward T. Hall developed proxemics during the 1950s. Hargie and Dickson (2004, p. 69) identified four types of territories as shown in Table 2.1.

Table 2.1 Types of Territories

S. No.	Classification	Description
1	Primary territory	One's own area; entry to others with permission only, e.g., own office cabin.
2	Secondary territory	No 'right' to occupancy, but routine use gives attachment, e.g., a seat in the bus, usually occupied.
3	Public territory	Area, which is given to all, for sometime, e.g., parking space.
4	Interaction territory	Space created by others when they interact.

Chronemics

Chronemics studies the use of time in non-verbal communication. Time is an important determinant of a person's image.

Punctuality: If a person is punctual, he is rated efficient and organized. However, late coming is common in case of guests. Making people wait is considered a status symbol in their case.

Speed of action: The timing of an action is important. Dynamic managers make quick decisions and implement them fast. Participative managers take time to decide as it requires contribution by all participants. Some managers are slow in decision-making. It signifies conservative attitude or laziness of the decision maker.

NOTES

Frequency of an action: If an individual is frequently absent, he or she is called chronic absentee, whereas if a person is absent now and then he/she is not labelled for this behaviour. Thus, frequency of an action is also an important factor in explaining behaviour.

NOTES

Paralanguage

Also referred to as *vocalics*, paralanguage is the study of non-verbal cues of the voice. These cues include the acoustic properties of speech, namely tone, pitch and accent, together called prosody. Paralanguage can emphasize or change the meaning of words.

A classification method that comprised the voice set, vocalization and voice qualities was advanced by George L. Trager. Table 2.2 shows the classification of voice system.

Table 2.2 Classification of Voice System

S. No.	Classification	Description	Elements
1	Voice set	Context of speech	Situation, gender, mood, age and a person's culture
2	Voice qualities	Which gives each individual a unique voice print	Volume, nasality, tempo, resonance, rhythm, articulation, pitch and accent
3	Vocalization	Characterizers	Emotions expressed while speaking like laughing, crying and yawning
		Voice qualifier	The style of sending a message, e.g., yelling
		Vocal segregates	Such as 'uh-huh' to indicate that the listener is listening

Haptics

The study of touching behaviour as non-verbal communication is known as haptics. Different kinds of touches are:

- Handshakes: Shaking hands to greet a person
- Kissing: Lip touch on lip, cheek or hand top signal welcome or love
- Slapping: Soft slap shows intimacy, hard slap shows anger
- Patting: On the back, on the cheeks, indicate appreciation.
- Scratching: Scratching head indicates doubt

The background of the situation determines the meaning conveyed from a touch, including the way one is touched and the personal dynamics between communicators.

Oculesics

It refers to the role of eyes in non-verbal communication. Eye contact shows attention, interest, and involvement. Glancing indicates passing interest whereas gazing indicates intense interest. Staring is interpreted as anger or confusion. Blinking indicates ignorance.

Kinesics

The study of body movements, facial expressions and gestures is called kinesics. It is the non-verbal behaviour of the whole or part of the body. It examines and interprets behaviour, such as mutual gaze, smile, facial warmth or pleasantness. Ray L. Birdwhistell, a ballet dancer who later on became an anthropologist, advanced this concept in the 1950s. He wanted to understand how people interact with gestures, stance, and posture. As phoneme is known as a unit of sound, kineme is the unit of body movement. However, many people prefer the term body language to denote kinesics.

Important modes of non-verbal communication

The important modes of non-verbal communication are:

(i) Facial Expression

Facial expression may very well communicate the feelings, thoughts and intentions of the communicator. In general, face and facial expressions may be said to be a true index of one's emotional and thinking behaviour. When one is perturbed, his face gives the identity of the level of anxiety and stress. Similarly, when one is in a happy or joyous mood, his or her expression is almost similar and universal to all round the world. Seeing the facial expression, we can easily conclude if one is angry, fearful, jealous, astonished or showing love, sympathy or hatred. In this way, facial expression may be termed as one of the important modes of non-verbal communication.

(ii) Language of the Eye

Language of the eye may be considered as another important mode of non-verbal communication. Eyes, in fact, may convey all what is intended to be communicated by the communicator. Language of the eye may also be considered as common and universal to almost all cultures and societies of the world. The various idioms and phrases showing movements and actions of the eyes like 'Aankh Bichhana' and 'Aankhe Dikhana' easily provide valid testimonial of its role in communication.

The language of the eye movements is somewhat so universal and familiar that it is very easy and simple to decode the feelings, thoughts and intentions conveyed by the communicator. When one turns his eyes, we can conclude that he is not interested in our friendship or conversation or wants to avoid us. Similarly, one can communicate well his emotion of fear, jealousy, anger, enjoyment, hatred, greediness, temptation, lust, love, affection, apathy or sympathy through the eye language.

In classroom communication, the necessary interaction links between the teacher and pupils are mostly maintained through the related eye language. The eye movements of the teacher may encourage a student in giving response or participating actively in any teaching-learning activity. Similarly, by reading eye movements, the teacher can know whether the student is showing interest or disinterest in any classroom activity.

NOTES

NOTES**(iii) Body Language**

Our body has an impressive and effective language for communicating our feelings, thoughts and actions. A classical dancer while performing on the stage may provide a substantial proof of the effectiveness of such communication through various gestures, postures and movements of her body parts. By seeing the body language, one may well conclude that the other person is offering prayers, getting annoyed, nervous, tensed or feeling shy, fearful, angry, jealous, envious, anxious, in love, or affection.

The body language, although seems to be somewhat universal and common, yet has a perfect cultural and social base. As a result every culture or society has its own body language which can be learnt the same way as the spoken language. Hence, one should be quite cautious while making use or interpreting body language in communication. Let us cite a few instances for this purpose:

- In Tibet, the tribal people exchange greetings by protruding their tongues. In India, it will be communicated as insulting and teasing the receiver.
- In India, you may use your stretch open palm for conveying the stop signal. However, doing such in Greece will be an outright insult to the receiver.
- In the western culture, people may welcome or greet through kissing, whereas kissing in public is not liked in India. We usually welcome or greet through joining hands, touching feet or shaking hands.

The body language in its broad form may include various types of gestures and physical movements of the body parts. In such a broad form, it is quite commonly used by all speakers, stage or media actors, political and religious leaders, lawyers and advertising models while giving their performances at their workplaces. In our day-to-day conversations, we all are quite habitual in making use of it for communication. We convey the feelings of respect to our elders by touching their feet, welcome through joining our hands or say goodbye by shaking or raising our right hand. Our body indicates our feelings of anxiety, fear, anger, happiness, sadness, affection, hatred, empathy and sympathy through its various actions and movements. Body language can be very effectively used by the teachers and pupils in the classroom for healthy classroom interaction in almost all types of teaching-learning situations. Teachers may add colours and effectiveness to their explanations, expositions and demonstration skills, with the use of appropriate body language.

(iv) Sound Symbols

Many sound symbols and vocal cues also prove to be an effective medium for the desired communication. For example, when we are saying, narrating or explaining something to somebody and he is responding simply by uttering the sound hunh-hunh-hunh, it may work well for maintaining the chain of communication. We may properly visualize that he is paying attention and agreeing to the message communicated to him. Contrarily, when the listener utters the negative sound 'unu

hunch, it shows his disinterest or disagreement to the conveyed message. It becomes more distinctive and prominent when he also nods his head and neck along with the utterance of the negative sounds. Similarly, the utterance of the sound 'uanh' accompanied with the turning of the neck provide a signal of one's complete disliking or even feeling of hatred.

In addition to playing the role of a mediator in conversation, the sound symbols or vocal cues may effectively act as potent carrier and conveyer of one's thoughts and actions. For example, when one is making a pleasant sound through whistling or humming we may know that he is in a pleasant and happy mood and when one utters 'hunn' with anger he is said to be angry or in a fighting mood. However, the interpretation of the sound symbols can only be made in context to the tone, volume and the situation prevailing at the time of the utterances of these sounds, i.e. whistling may be made to tease, attract and making indecent remarks to somebody.

(v) Symbolic Code Language

Many times some special code language can also be used as an effective mode for the desired communication. The special code language prepared through the help of various gestures, postures and body movements can be used for communicating with deaf and dumb people. You may very well judge the effectiveness of such communication if you have ever seen the telecasting of the news bulletin specially meant for the deaf and dumb population. One can also mix vocal cues and sound symbols with the body language for having a code language. Since it is to be commonly shared, it must be well understood, used and interpreted in any form by its users. The users (senders and receivers), thus, are free to invent any set of code language using any type of verbal and non-verbal symbols commonly shared among them.

In our day-to-day life also, we must have heard some groups of children or youngsters often talking to each other in their own code languages. During games different team members use the code language to give instruction or message to other team members. You may feel helpless in making any sense of their communication but they have their language for proper communication. Similarly, various types of well-thought and organized code languages are very effectively used in exchanging quite meaningful and secret information by the detective and security agencies operating all over the world. In this way, any commonly shared code language may prove an effective mode for the desired communication between the shared group members.

(vi) Print and Non-Print Media in Communication

Both print and non-print media are used in the communication process. Both these media can be classified as per the following diagram:

NOTES

NOTES

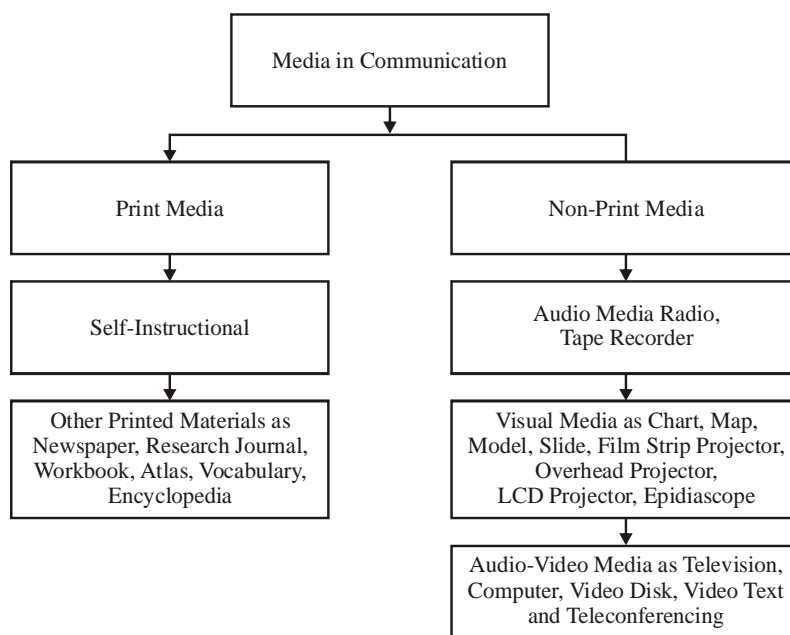

Fig. 2.4 Print and Non-Print Media

CHECK YOUR PROGRESS

4. What are the basic units of language?
5. What aspect of non-verbal communication does chronemics study?
6. By whom and when was the concept of kinesics advanced?

2.4 FACTORS AFFECTING CLASSROOM COMMUNICATION

The quality and effectiveness of the process of communication is affected favourably or adversely through the presence of some other intervening variables lying between the source of communication and the receiver. These variables according to their nature, helping or obstructing the path or communication may be termed as facilitators or barriers of communication. The presence of congenial, physical, psychological and environmental conditions and facilities available for effective communication may facilitate and help in providing the desirable effectiveness to the communication system. Barriers may cause simple communication gaps or total failure of communication. Some major barriers of communication are as follows:

- **Lack of common language:** Language uses oral or written symbols to transmit messages from one person to another. If the sender and the receiver of a message do not belong to the same language group, then this deficiency will pose an obstacle to the process of communication. The sender and the receiver will not be able to communicate with each other if they do not know

a common language. Communication will not be possible between a boy who can only speak only in English and another boy who can only speak in French.

- **Semantic barrier:** It is possible for one word to have many different meanings. It is not necessary for the meaning that is ascribed to a word by the communicator to be the same as that ascribed by the receiver to the same word. One word can have different meaning for different people at different points of time. Hence, it is possible that the sender and the receiver, most of the time, ascribe different meanings to the same word. Occasionally, they might possibly make use of dissimilar words to communicate the same meaning.
- **Poor listening:** Poor listening skills are one of the chief problems while communicating. If people are attentive in listening a lot of misunderstanding can be reduced. A large number of people do not pay value added attention to the message because of a variety of disturbances, feelings, enthusiasm, absence of interest, unwarranted assertiveness and roving concentration. This usually leads to misunderstanding and conflict.
- **Poor vocabulary:** Low level of vocabulary is an obstacle to the communicator in conveying the message in its exact form. It makes the message more complicated and reduces its effectiveness. If the recipient cannot figure out the words, he will not be able to comprehend the sentences.
- **Noise:** A lot of noise also affects communication. Noise is usually, but not always, in the form of sounds. It can be visual, audio-visual, written, physical or psychological. Noise, in a physical form denotes the loud noise made by machines or speaker or other such things. Noise occurs when a student arrives late for a class and his arrival becomes a source of distraction for others in that class. Bad handwriting and incorrect typing leads to written noise. Psychological noise refers to mental trouble and turmoil, inattentiveness and indifference.
- **Time:** Time factor may also hinder the process of communication. For example, a phone call at midnight may irritate the receiver and he may not listen to the communicator. Thus, his communication becomes ineffective. The best of communication may prove to be ineffective if it does not take place at the right time.
- **Distance:** The distance between one who communicates the message and one who receives it may be a strong obstacle to communication. This can be due to absence of technical equipment such as telephone, telefax, for linking them. An unfavourable system of seating in the classroom can give rise to a type of communication gap, which can be eradicated by making adjustments in the distance.
- **Attitudes and values:** People interpret messages on the basis of their attitudes and values. If a message is adverse for the receiver, it will not be able to persuade him easily. Thus, personal attitudes, values and opinions are transformed into obstacles, in the process of effective communication. Negative attitude of a teacher or a student may affect communication in the classroom.

NOTES

NOTES

- **Emotional barrier:** Emotions refer to the way we feel about the world around us. Constructive emotions like happiness, adoration or liking make the flow of communication smooth. However, negative emotions like fear, distrust, anger, anxiety and hatred, work as powerful hindrances to efficient means of communication.
- **Different perceptions:** Different perceptions of different people have their own limitations. According to Francis Bacon, 'man prefers to believe what he prefers to be true'. Our reality is created by us with the help of selective perception. This conceals specific things that are present and reveals other more specific things, in addition to those which are already present. Every person's experience and his way of interpreting things are never the same since every person has a perception of his own. A communication barrier emerges, when the same object or concept is interpreted differently by two or more people.
- **Wrong channel:** At times, simple rules for selection of a channel cause more problems than they solve. In selection of a channel, the sender needs to be sensitive to things like complexity of message, consequences of a misunderstanding, knowledge, skills and abilities of the receiver and timely response on receiving the message.
- **Poor retention:** There is a limit to the functioning of human memory. Everything that is said cannot be always retained. The retention is even lower if the receiver is not interested or attentive. This causes a breakdown in the process of communication.
- **Closed mindedness:** It is not at all easy to communicate with a person with intense prejudice. This type of a person is not ready to receive any message on a subject about which he believes that he knows everything. His mind is closed to new ideas, facts and proposals. Hence, he completely rejects the information and recommendations of the communicator, even before he knows the real facts.
- **Physical distractions:** Physical distractions are physical things that interrupt communication. For example, uncomfortable seating arrangement makes it difficult for a learner to concentrate on the communication.
- **Lack of proper feedback:** Without feedback, communication is one-way. Feedback in terms of proper motivation, incentives, zeal and enthusiasm is needed on the part of the sender and the receiver. If, in a classroom the teacher is not getting feedback of his teaching, he may never achieve the actual goal of teaching.
- **Too much information:** Excess of information also acts as a communication barrier. A lot of information faces many drawbacks and different respondents react differently to filter the information and receive only what they need. Hence, for effective communication, the amount of information can be reduced.

2.4.1 Barriers to Effective Classroom Communication

Sometimes obstructions are confronted in communication, as a result of which the transmitted message either goes wrong or received incompletely. Sometimes, communication relations are broken down. Among other types of barriers are included: a message being misread, a message having more than one meaning, deformities in a message, limitations of the message-receiver, shortcoming in the communication channel, and sound pollution.

Dr Kumar (1996) has tabulated the chief barriers in communication as follows:

Table 2.3 Barriers in Communication

Types of Barriers	Barriers
Physical barriers	Noise, invisibility, environment and physical inconveniences, poor health, lack of attention
Linguistic barriers	Verbose, unclear words, unnecessary words, grinding words, wrong pronunciation, unclear graphics and symbols
Psychological barriers	Prejudice, disinterest, wrong perception, unrewarding experience, more than necessary anxieties, incomplete curiosities
Background barriers	Previous learning, cultural discrimination, previous work situation and environment

Barriers of communication can be classified into three types:

- Barriers related to message-sender
- Barriers related to message transmission
- Barriers related to message-receiver

These barriers and difficulties can be classified in another way into the following types:

- Linguistic barriers
- Technical problems related to transmission
- Problems related to the process of mutual influence
- General problems related to transmission

Some Other Barriers

- **Noise:** Noise is a great barrier. Many times a message is lost in the noise, and it may be received incorrectly. Here, noise becomes a barrier.
- **Language:** A word may have several meanings. Therefore, the use of word should be clear as to its context and place, else there may be misunderstanding.
- **Previous experience:** Sometimes we try to understand a stimulus on the basis of our past experiences. These past experiences are related to our background. Background experiences, needs, values and stimuli play an

NOTES

NOTES

important role in encoding and decoding of a message. Sometimes the background experiences, needs, stimuli and values are very helpful in understanding a message correctly, and sometimes they become a barrier in understanding a message correctly.

- **Emotions and sentiments:** Different types of reactions occur in the mind on listening different types of words. These reactions depend on our emotions and sentiments. Favourable words give us good reactions and unfavourable words give incorrect reactions. Incorrect reactions result in misreading of the message. Thus, emotions and sentiments function like a barrier in the communication process.
- **Situational context:** When a word, sentence or phrase is seen out of its context, then its sense undergoes a change, and the right meaning is lost. In such a situation, a message gives a wrong meaning. Therefore, it is necessary to look at a message in the right context; else it will work as a barrier in the communication process.

2.4.2 Guidelines for Better Communication in Classrooms

Effective communication is the essential requirement for having an effective interaction or getting maximum advantages from the process. In this way, the degree of its effectiveness can be judged from the amount of advantages drawn through it.

Now the question arises what should be done for realizing the utmost effectiveness in communication. The answer is very well linked with our attempts in improving each component or element involved in the process of communication. Let us think over the ways and means to bring efficiency in the nature and working of these components.

Following aspects should be given attention in order to overcome barriers in communication in order to affect an effective communication:

- As far as possible, clear, simple and comprehensible language should be used
- A message should be written such that the message–receiver can understand it well
- If there is a need to lay stress on a certain point, then this can be repeated, but to a certain extent
- More than one channel can be used simultaneously or one after another
- There should be provision for feedback, only then it can be ascertained whether the message has been transmitted in the real sense
- The elements delaying the process of communication should be paid attention to
- The habit of listening should be cultivated. For it, the following points should be looked into:
 - o It is wrong to guess the message in the envelope by looking at the message-carrier or its envelope. The habit to listen to the message or message-carrier should be cultivated.

- o More attention should be paid to the facts mentioned in the message as compared to the views on it.
 - o If some point has not been cleared in the class, then the problem should be presented at the end of the class instead of asking it immediately, so that the teacher can be heard without any interference from beginning to end.
 - o Listen carefully. Do not give a false impression of listening to the speaker.
 - o While listening, do not pay attention to other visuals or noise.
 - o Whatever you are listening, listen it completely and attentively.
 - o When you are asked something, listen properly and then answer. It is not good to guess.
 - o Attention should be paid to the speaker's facial expressions, voice, rate of speaking.
 - o Cultivate the habit of listening actively.
 - o Keep in mind, a good listener is able to transmit well.
 - o The message of the speaker should be heard attentively.
 - o If somebody is speaking loudly in the proximity and you are facing difficulty in listening, tell him to shut up.
 - o Never think that what the speaker is telling is already known to you. Even if you know it, listen attentively; it may be possible that you may get some new message in it which you did not know before.
 - o Listen to the speaker attentively, think over it and try to find out its inner, intended and deep senses.
 - o If you are asked a question, listen to it attentively and then determine what answer you will like to give. Your answer should be given in simple and correct language.
 - o When you listen, listen mindfully, actively and keep noting the important points in brief.
- Read the written message well. If need be, read it again. Then ask yourself the following questions:
 - o What is being said in the message?
 - o What is the purpose of the message?
 - o What has been said at different points in the message?

NOTES

CHECK YOUR PROGRESS

7. How is the quality and effectiveness of the process of communication affected?
8. How can barriers of communication be classified?
9. State how language is a barrier to communication.

2.5 OBSERVATION SCHEDULES OF CLASSROOM INTERACTION

NOTES

The beginnings of the classroom observation research can be traced back to the initial years of the second decade of the 20th century (Hammersley, 1986, p. xi). Rather than representing a single type of research methodology, 'classroom observation research covers a wide variety of investigations and techniques. By the seventies, the decade when such studies grew exponentially, hundreds of classroom observation instruments had been developed' (Borich and Madden, 1977).

Assessable studies usually recognize the target behaviour before the observation and hence prepare a checklist or a kind of schedule which is then made use as tools in classroom settings to record or measure the intensity of occurrence of the recognized behaviour. Structured Classroom Interactions Schedule (SCIS) consisted of an observation schedule or checklist which was adept of recording up to six characteristics for each observed classroom interaction that took place between teachers and students. Corresponding to every interaction, the Structured Classroom Interactions Schedule acknowledged a source who was either a student or teacher or a target. A teacher may question a student by calling out the name of a particular student, here the SCIS recognizes the target as being chosen. Similarly, the teacher may put the question open to all the students, where a student raises his/her hand to answer the question, in this case the SCIS identifies the target as a volunteer for the interaction. There may be a situation where the student answers before being addressed or recognized in any manner, in this case, the SCIS classifies or distinguishes the interaction as a yell.

Besides the source and the target, the SCIS also classifies the interactions between the teacher and student with respect to their type, object, outcome and feedback. When dealing with type, the interaction is categorized as a query or a declaration or an argument. The idea behind the interaction was the resolution behind the interaction, what the interaction is all about. There are various categories as classified by the SCIS of the purpose—process, management, knowledge and discipline. Outcome and feedback were important aspects of the interaction where outcome was further classified by classifying the responses of the students. Whereas, feedback was for those interactions that did not conclude with a particular kind of outcome. Feedback can be of three types—no feedback, positive and negative feedback. Positive feedback was given when the interaction between the source of interaction and the target was up to the mark, similarly, negative feedback was given when the interaction between the two was unsatisfactory. No feedback meant that the interaction did not go past the outcome.

Classroom Climate

Almost all the research carried out in the field of the role of the teacher is related to the all-pervasive, social-emotional atmosphere termed as 'classroom climate'. Withall defines climate as 'emotional tone concomitant of interpersonal interaction'. Cogan

defines this term as ‘referring to the dominant effect, the pervasive, patterned emotional components of the transactions occurring in a teacher’s classroom’ (24). The classroom climate can be considered to be all-pervasive and inclusive only when the classroom is seen as a complicated and symbiotic system. This interdependency observation has been made by the ‘ripple effect’ research. The classroom climate is an environment that emerges from the authority of the teacher had been demonstrated by researchers such as Dyke and Hughes. The classroom climate depends on various factors—motivation of the teacher, pupil interest, pupil-teacher relationship and pupil-pupil relationship. The negatively motivating teacher will threaten the child and fail to challenge. The positively motivating teacher will challenge the child while simultaneously making him feel safe and secure to act.

NOTES

2.5.1 Importance of Observation

With the development of psychology as an objective science of behaviour, the method of introspection was replaced by careful observation of human and animal behaviour to collect data by research workers. Observation literally means looking outside one-self. It is one of the important and basic methods for collecting data in almost all types of research studies. It produces one of the basic elements of science, i.e., facts that are collected by observing the overt behaviour of the organism in order to locate underplaying problems and to study developmental trends of different types. Overt behaviour is the manifestation of cover conditions within the organism. The study of overt behaviour, indirectly gives the clue to the mental condition of the organism. The development of systematic observation, as a method of collecting data, generated interest in developmental psychology and many studies on developmental characteristics of students were conducted that made great contributions to the field of child psychology. Observation may be of the following types: direct and indirect, natural and artificial, scheduled and unscheduled, participant and non-participant. Here, we will describe only two types of observations:

- (i) **Natural observation:** In natural observation, we observe the specific behavioural characteristics of students or teachers in natural settings. Subjects do not become conscious of the fact that their behaviour is being observed by someone. The teacher can observe the behaviour of his students on the playground or in any other social situation when students may not become conscious of his presence. In a child clinic, a one way screen is used to observe the behaviour of deviant children. The observer can observe the behaviour of students but cannot see the observer.
- (ii) **Participant observation:** In this form of observation, the psychologist establishes perfect rapport with a group of adolescents so that they may not become conscious of his/her presence and may not hide their actual behaviour.

Observation studies are particularly very important and yield significant result on the developmental characteristics of students. No doubt, observation is a scientific technique of collecting data whose results can be verified and relied upon to locate behavioural problems of different types but it suffers from the following limitations.

NOTES

Limitations of observation

The limitations of observation are as follows:

- Observation is useful only for collecting data over behaviour, which is manifested in a number of activities. This overt behaviour does not provide reliable information regarding the internal mental process. We can only guess about the mental state of the student on the basis of overt behaviour which may or may not be true. It becomes very difficult to draw any conclusion in case of adults who can hide their actual behaviour in the presence of the observer. In such cases observation fails and yields on tangible results, which may throw light on the actual behaviour of the subjects.
- Subjectivity of interpretation is another limitation of observation. The observer may interpret his/her sensations of external stimulus on the basis of his past experiences. He/she may be biased in his interpretation by his/her likings, disliking and value. The observation may be influenced by his/her perception of the situation when he/she makes inferences on the basis of scanty sensory cues. It also suffers from impressionism, prejudice and distraction. It has also been found in some studies that strong personal interests tend to make the researcher see only those things, which he/she wants to see.
- Observation is subjected to two kinds of errors, sampling error and observer's error. The first error occurs because of inadequacies of selecting the situation to be observed. The observer's error may be due to the knowledge and background of the situation to be observed. Sometimes the observer is not familiar with the total situation and hence may commit an error.

Suggestions for improvement

In recent years, improvements have been made in the methodology of observation to make it a more objective and reliable instrument of collecting data for research purpose. The following suggestions are given in order to eliminate the types of errors.

- *Use of mechanical devices:* Generally, observers do not record their observations immediately on the spot. However, observations should be immediately recorded. They should not be left for future because there is every possibility of their being contaminated with personal prejudices and left out due to failure of recalling. The use of a mechanical device, such as a camera or a tape recorder may be made to improve the reliability of observation. A system of notation or shorthand may be used for recording purposes.
- *Definite objectives:* The investigator must in advance specify in clear and definite the terms of the objectives of the observation. A detailed analysis of the behavioural characteristics that are to be observed should be ensured.
- *Schedule:* The investigators must decide the time and hour of observation and a schedule should be honestly followed. A detailed schedule in the form of questions or statements should be prepared in advance to note down the observations. The method of recording the observation should be made clear. It will be more reliable and objective if a numerical value is assigned to various

aspects of behaviour. Detailed instruction should be spelt out to minimize variations in recording observations by different investigators.

- *Training*: Observation is not a haphazard activity. It is a systematic and scientific method that requires skills. Competencies, aptitude, and proper training for observation, must acquire the broad background in the field of the investigator's problem. The investigator should train himself to counteract his/her emotional and intellectual biases in order to report accurate observation. For this purpose, he/she may get rigorous training on similar problems. He/she should develop keenness and alertness to identify minor incidents in observation. He/she should make comprehensive and complete notes of all pertinent incidents.
- *Precise*: He/she should make his/her observation in precise, concrete and unambiguous form. His/her description should mean the same thing to other investigators as they mean to him/her. It will be more reliable if the investigator describes his/her data quantitatively because numerical measures are more precise than words which make possible the further treatment of the problem by statistical analysis.

NOTES

CHECK YOUR PROGRESS

10. When can we trace the beginnings of the classroom observation research?
11. Name the types of observation.

2.6 FLANDERS' INTERACTION ANALYSIS CATEGORIES SYSTEM (FIACS)

Interaction analysis is that verifiable observation which provides the best foundation for systematic knowledge of the teaching–learning process in the classroom. Basically, interaction analysis has been used to help quantify a teacher's verbal behaviour. It provides an idea about the process going on inside the classroom in terms of teaching and learning. Interaction analysis is basically a process of encoding and decoding the teaching and learning pattern. In the coding process, categories of classifying statements are established. A code symbol is assigned to each category and a trained observer records the content. In the decoding step, a trained analyst interprets the display of coded data and reconstructs original events on the basis of the encoded data, even though he may not have been present when the data were collected.

The greatest use of interaction analysis has probably been in student-teaching or teaching internships where it is used for several basic purposes as follows:

- Developing skill in observation of teaching
- Providing a tool for analysis of teaching
- Providing a tool for feedback about one's teaching
- Setting a framework for practising and learning specific teaching skills
- Providing a framework for conceptualizing and developing various teaching styles

NOTES

The Flanders' Interaction Analysis System is the most renowned teacher-student classroom interaction observation system, which involves recording and analysis of teaching situations and teacher-student interaction analysis system events. Ned A. Flanders evolved this system in which a number of categories are used to encode. Accordingly, the classroom behaviour of the teacher and students is quantified. It takes into account both direct and indirect teaching behaviour. The purpose of developing the observational system is that a teacher can be trained to use it for analysing classroom behaviour, and for planning and studying his own teaching activities.

2.6.1 Basic Theoretical Assumptions of Interaction Analysis

Various theoretical assumptions which are basic to the very idea of interaction analysis are as follows:

- In a normal classroom situation, it is verbal communication, which is predominant (Flanders, 1965).
- Even though the use of spoken language might be resort to non-verbal gestures in a classroom, verbal behaviour can be observed with higher reliability than most non-verbal behaviour.
- We can normally assume that verbal statements of a teacher are consistent with his non-verbal gestures, and in fact, his total behaviour. This assumption was sustained in terms of experience in Minnesota studies (Flanders, 1966).
- The teacher exerts a great deal of influence on the students. Student's behaviour is affected to a great extent by the teacher's behaviour exhibited (Anderson and others, 1946).
- The relation between students and teacher is a crucial factor in the teaching process, and must be considered an important aspect of methodology (Haggerty, 1932).
- It has been established that social climate is related to productivity and to the quality of interpersonal relations. It has been proved that democratic atmosphere tends to keep work of a relatively high level, even in the absence of the teacher (Lewin and other, 1939).
- The role of classroom climate is crucial for the learning process (Perkins, 1956).
- Modification of teacher-classroom behaviour through feedback is possible (Flanders, 1963), though how much change can occur and extended knowledge relating to the permanence of these changes will require further research (Flanders, 1963 and 1966).
- A teacher's influence is expressed primarily through verbal statements. Non-verbal acts of influence do occur, but are not recorded through interaction analysis.
- These assumptions focus on the verbal participation of teachers and students in teaching.

2.6.2 Categories of Flanders' Interaction Analysis

All verbal behaviour to be found in the classroom is divided into 10 categories in Flanders' interaction analysis. There are three major sections in which these 10 categories are grouped. These sections are teacher talk, student-talk and silence or confusion. There are seven categories in teacher-talk section. Out of these, the first four categories belong to indirect influence and last three to direct influence. Indirect influence mainly encourages student participation and freedom of expression of their thoughts. On the other hand, direct influence increases teacher's control and provides less freedom to students. Student-talk is divided into two categories which provide a hint to the nature of freedom given to students. The third section includes pauses, silence, and periods of confusion.

NOTES

Table 2.4 Flanders' Interaction Analysis Categories (FIAC)

	Category number	Activity
Teacher talk (Indirect influence)	1.	Accepts feeling: Accepts and clarifies an attitude or the feeling tone of a student, in a non-threatening manner. The feeling may be positive or negative. Predicting and recalling feelings are included.
	2.	Praises or encourages: Praises or encourages student action or behaviour.
	3.	Accepts or uses ideas of students: Clarifying or building or developing ideas suggested by a student.
	4.	Asks questions: Asking questions about content based on teacher ideas, with the intent that a student will answer.
Teacher talk (Direct influence)	5.	Lecturing: Giving facts or opinions about content or procedures, or citing an authority other than a student.
	6.	Giving directions: Directions, commands or orders to which a student is expected to comply.
	7.	Criticizing or justifying authority: Statements intended to change student behaviour from non-acceptable to acceptable pattern.
Student-talk	8.	Pupil-talk response: Talk by students in response to teacher. Teacher initiates the contact or solicits student statement, or structures the situation. Freedom to express own ideas is limited.
	9.	Pupil-talk initiation: Talk by students, which they initiate. Expressing own ideas; initiating a new topic; freedom to develop opinions and a line of thought, like asking thoughtful questions; going beyond the existing structure.
Silence	10.	Silence or confusion: Pauses, short periods of confusion, in which communication cannot be understood by the observer.

NOTES

2.6.3 Observation of Classroom Events

The observer memorizes the codes given to the 10 categories. He sits in the classroom for at least 20 minutes and observes the teacher while teaching. At an interval of three seconds, he writes down the category which best represents the behaviour just completed. For example, if a teacher praises a student in order to encourage him, then the observer writes 2; when teacher gives a lecture, then the observer writes 5. Each number is being marked in three seconds, which means, about 400 numbers would be marked in 20 minutes. The numbers are written in a column on a plain paper by the observer, according to the 10 categories of Flanders' verbal interaction. The observer should also note down other additional facts, if any, which might appear to be significant for analysing the verbal interaction in the classroom.

Some ground rules for observation

Certain rules have been established for categorizing the classroom behaviour, as observation or recording Flanders' interaction analysis is quite a complex phenomenon. It would be impossible for the observer to use this method without following these rules. The observer has to follow these rules:

- **Rule 1:** If the observer is not sure about the category to which a particular behaviour belongs, then the category that is numerically farthest from category 5 should be selected. For e.g., between 3 and 4, the observer should choose 3 as it is farthest from 5.
- **Rule 2:** If the teacher's talk is consistently direct or indirect, then do not change the category unless a clear indication of change is given by the teacher.
- **Rule 3:** The observer should not be concerned with his own biases.
- **Rule 4:** If more than one category occurs in three seconds, all categories used in that interval should be recorded.
- **Rule 5:** If silence exceeds more than 3 seconds, it should be recorded in category 10.
- **Rule 6:** If the teacher repeats a student's correct answer, then it should be recorded in category 2.
- **Rule 7:** If all the students respond collectively to a question, then the serial number of category 8 is recorded.
- **Rule 8:** If a teacher cracks a joke on a student, then it belongs to the category 7.

2.6.4 Construction of Interaction Matrix

After recording 400 numbers in 20 minutes, the observer leaves the classroom and does chaining or pairing of numbers. A matrix table of 10 rows and 10 columns is constructed. While constructing the matrix, one pair is marked at a time. Entire series should begin and end with the same number. The convention is to add 10 in the beginning and at the end of the series. The first number of each pair denotes a row and second number denotes a column. For example, if the first pair is (10, 7), the first number 10 denotes a row and the second number denotes a column. Each pair overlaps the other pair. Pairing is done as under:

$$\begin{array}{c} 10 \\ \left[\begin{array}{c} 7 \\ 5 \\ 5 \\ 8 \\ 9 \\ 6 \\ 8 \\ 5 \\ 4 \end{array} \right] \end{array}$$
NOTES

After pairing, the pairs are now entered in the matrix as given in the Table 2.5. The first pair (10, 7) has been tallied in the cell located at the intersection of the 10th row and the 7th column. Similarly, the next pair (7, 5) has been tallied in the cell located at the intersection of the 7th row and the 5th column. All pairs have been tallied in the same manner in the matrix. The total observations are denoted by N.

Table 2.5 Matrix Pairing

	1	2	3	4	5	6	7	8	9	10	Total
1											
2											
3											
4											
5				1	1			1			3
6								1			1
7					1						1
8					1				1		2
9						1					1
10							1				1
Total				1	3	1	1	2	1		9

2.6.5 Interpretation of Interaction Matrix

There are different ways to interpret this interaction matrix. The simplest way of interpreting the interaction data is to convert behaviour in terms of percentages, which explain the use of various categories by a teacher during classroom interaction. The other method is to convert tallies of matrix into certain behaviour ratios. The calculation of these behaviour ratios can be done by using formulas which have been constructed for this purpose. Fifteen behaviour ratios have been considered, which are explained below:

- (i) **Teacher-talk ratio (TT):** Teacher-talk ratio represents the performance of the teacher in terms of actions reflecting the tendencies of teacher talk. It is calculated by adding the first seven categories, multiplied by 100 and divided by N, i.e., total tallies:

NOTES

$$TT = (1 + 2 + 3 + 4 + 5 + 6 + 7)/N \times 100$$

- (ii) **Indirect teacher-talk ratio (ITT):** Indirect teacher-talk ratio represents the performance of the teacher in terms of supporting and encouraging student participation. It is calculated by the following formula:

$$ITT = (1 + 2 + 3 + 4)/N \times 100$$

- (iii) **Direct teacher-talk ratio (DTT):** Direct teacher-talk ratio represents actions of the teacher, which limit student participation. It can be calculated by the formula:

$$DTT = (5 + 6 + 7)/N \times 100$$

- (iv) **Student-talk ratio (PT):** Student-talk ratio represents the response of students in response to the teacher. It can be calculated by the formula:

$$PT = (8 + 9)/N \times 100$$

- (v) **Silence or confusion ratio (SC):** This includes the duration of silence or confusion in the classroom, which cannot be included in any other category. It can be represented by the formula:

$$SC = (10)/N \times 100$$

- (vi) **Indirect to direct ratio (I/D):** It involves a proportion of indirect and direct influence of the teacher. Its formula is:

$$I/D = (1 + 2 + 3 + 4)/(5 + 6 + 7) \times 100$$

- (vii) **Pupil initiation ratio (PIR):** It represents the extent of student-talk during interaction in terms of initiation judged by the observer. It is calculated by the formula:

$$PIR = (9)/(8 + 9) \times 100$$

- (viii) **Teacher response ratio (TRR):** It represents the index of teacher's tendency to the ideas and feelings of students. It is calculated by the formula:

$$TRR = (1 + 2 + 3)/(1 + 2 + 3 + 6 + 7) \times 100$$

- (ix) **Teacher question ratio (TQR):** It represents the teacher's behaviour in terms of asking questions, when guiding the content-oriented part of the class interaction. The formula is:

$$TQR = (4)/(4 + 5) \times 100$$

- (x) **Context cross ratio (CCR):** It represents the proportion of classroom activity related to the teacher's question and lecturing with respect to his total classroom interaction. The formula for its calculation is:

$$CCR = (4 + 5)/N \times 100$$

- (xi) **Steady state ratio (SSR):** It reflects the tendency of teacher and student-talk to remain in the same category for period longer than three seconds. SSR can be determined by calculating the percentage of all tallies that lie within steady state cells. Its formula is:

$$SSR = \text{Steady state cells}/N \times 100$$

- (xii) **Student steady state ratio (PSSR):** It represents the tendency of student-talk to remain in the same state for a period longer than three seconds. It is the percentage of (8, 8) and (9, 9) out of categories 8 and 9. The formula is:

$$PSSR = (8, 8) + (9, 9)/(8 + 9) \times 100$$

- (xiii) **Instantaneous teacher response ratio (ITRR):** It is an index of the teacher's tendency to praise or integrate ideas and feelings in the class when the student stops talking. The formula for calculation is:

$$ITRR = (8, 1) + (8, 2) + (8, 3) + (9, 1) + (9, 2) + (9, 3)/(8, 1) + (8, 2) + (8, 3) + (8, 6) + (8, 7) + (9, 1) + (9, 2) + (9, 3) + (9, 6) + (9, 7) \times 100$$

- (xiv) **Instantaneous teacher question ratio (ITQR):** It is defined as the tendency of the teacher in response to student-talk with questioning based upon his own ideas compared to his tendency to lecture. It can be calculated by the formula:

$$ITQR = (8, 4) + (9, 4)/(8, 4 + 8, 5) + (9, 4 + 9, 5) \times 100$$

- (xv) **Vicious circle ratio (VC):** It indicates teacher's restrictive behaviour involving directions and self-justification. The formula is:

$$VC = (6, 6) + (6, 7) + (7, 6) + (7, 7)/N \times 100$$

Interpretation of behaviour ratios

After computing the behaviour ratios by using the above formulas, these ratios can be interpreted with the help of norms. Flanders developed norms for various grades in USA. Norms have also been developed according to the Indian setup.

The teachers exhibiting greater values of behaviour ratios mentioned on serial numbers 2, 4, 5, 6, 8 and 11, than the norms provided above may be termed as effective teachers, while those exhibiting greater values of behaviour ratio as mentioned on serial numbers 1, 3, 7, 9 and 10 may be termed as ineffective teachers.

2.6.6 Advantages of Flanders' Interaction Analysis

It is the most widely used interaction analysis due to its various advantages. Some of its major advantages are as follows:

- It is a useful means of identifying, studying, classifying and measuring specific variables, as they interact within instructional learning situation.
- With the help of the interaction matrix, a clear picture of the occurrences of the classroom can be drawn, even in the absence of the observer.
- It helps in determining the pattern and flow of teaching behaviour in the classroom.
- It is an effective tool to measure the social-emotional climate in the classroom.
- This analysis would serve as a vital feedback to the teacher or the trainee-teacher about his intentions and actual behaviour in the classroom. The supervising or inspecting staff can also easily follow this system.
- It helps in the modification of teacher's behaviour.

NOTES

NOTES

- Different matrices can be made and used to compare the behavior of teachers at different age levels, sex, and subject-matter.
- It is a very useful method for in-service teachers.
- It is very helpful in the area of research in the field of teacher education.
- It adds and supplements the training techniques such as microteaching and team teaching.

2.6.7 Disadvantages of Flanders’ Interaction Analysis

Flanders’ interaction system also has some limitations which are as follows:

- This method does not provide information about all aspects of the classroom as it is mainly concerned with verbal behaviour. As a result of this, some behaviour aspects are overlooked, which might be very important.
- This method is quite difficult and time consuming. Construction of 10×10 matrix takes much time.
- The main focus of this method is towards teacher-talk, and a very limited attention has been paid towards student-talk in this method.
- This method requires a highly trained, reliable and competent observer which are always in acute shortage.
- It does not provide value judgments about good and bad teaching behaviour.
- Certain activities like demonstrating an experiment in science, model reading in language, map and chart reading in social studies do not find appropriate classification in this system.
- The system of interaction analysis is content-free. It is concerned primarily with the social skills of classroom management, as expressed through verbal communication.
- Only one category has been provided to silence and confusion. Moreover, no attempt has been made to classify silence as purposive and non-purposive.

CHECK YOUR PROGRESS

12. State the reason why interaction analysis been used by teachers in schools.
13. What is the simplest way of interpreting interaction data?
14. List any two advantages of Flanders' Interaction Analysis.

2.7 TEACHING

Teaching is considered to be a social phenomenon. Teaching is an art in which a teacher influences his students and motivates them for learning. Students learn and develop according to the ideals set before them by teachers. Teaching is nothing but an organized set of activities, as a result of which pre-determined objectives are achieved. The success of teaching process depends upon the sincerity and hard work of teachers. Communication plays a big role in teaching as the whole process

of teaching involves various forms of communication. Teaching should not be confused with conditioning, training, instruction and indoctrination. However, all these may help in the process of teaching. Teaching is more complex, wide and comprehensive in comparison to all these four terms. A teacher should have a number of skills. Let us discuss the whole process of teaching and some steps, which are performed by a teacher.

Definitions of Teaching

A few popular definitions of teaching are as follows:

- In the words of John Brubacher (1939): ‘Teaching is an arrangement and manipulation of a situation, in which there are gaps or obstructions which an individual will seek to overcome.’
- According to H.C Morrison (1934): ‘Teaching is an intimate contact between a more mature personality and a less mature one, which is designed to further the education of the latter.’
- According to B.D Smith (1961): ‘Teaching is a system of actions intended to reduce learning.’
- According to Clarke (1970): ‘Teaching refers to activities that are designed and performed to produce change in student behaviour.’

Assumptions of Teaching

Some assumptions of teaching are as follows:

- The teacher is a professional who is capable of making rationale, humane and creative decisions.
- The primary purpose of teaching is to facilitate student learning.
- Student learning can be measured only through observations that reveal changes in behaviours.
- The act of teaching is a complex process that is influenced by a field of forces, of which teachers can be aware only in part and which they can only partially control.
- Teaching is an activity that can be described and analysed.
- Teachers should teach objectively and enable students to evaluate their teachings.

Characteristics of Teaching

According to the definitions and assumptions of teaching, the characteristics of teaching can be interpreted in the following ways:

- Teaching is an interactive process between a teacher and a learner. It is not a one-sided affair as both the learner and the teacher have to be fully active during this process.
- Teaching is not an independent activity as it cannot happen in vacuum. It takes place in some social set-up where the teacher aims at modifying the behaviour of an individual or group.

NOTES

NOTES

- Teaching is both formal and informal. Both the ways, it helps in achieving the desired goals.
- The process of teaching is carried out to achieve some specific aims and objectives.
- Teaching is a cooperative activity and a teacher should involve students in different classroom activities such as organization, management, discussion, recitation and evaluation.
- Teaching is dominated by the process of communication. Good communication skills make teaching interesting and lively.
- Teaching is not only about motivating students to learn, but also enabling them to learn in a manner that is relevant, meaningful and memorable.
- The main aim of teaching is to provide guidance to learners, according to their capabilities.
- The purpose of good teaching is to develop independence of thought, self-reliance and confidence among students.
- Teaching is a tri-polar process and its three poles are: teaching objectives, learning experiences and behaviour modifications.
- Effective teaching provides feedback for both students and teachers.
- Teaching is remedial and the teacher must solve the problems of students.
- Teaching is an observable, measurable and modifiable process. A teacher’s behaviour can be observed and measured with the help of various supervisory techniques and their analysis.
- Teaching is a well-planned activity and teachers plan the objectives, methods of teaching and evaluation techniques in advance.
- Teaching is a democratic process as it provides the learner with an opportunity to present his view.

2.7.1 Variables of Teaching

Various types of variables are involved in the process of teaching. The teaching process takes place as a result of the activity of these variables as shown in Figure 2.5.

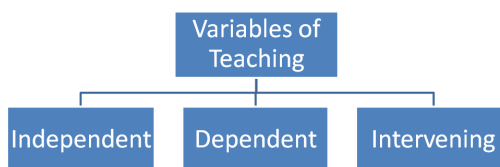

Fig. 2.5 Variables of Teaching

There are mainly three variables in the process of teaching. These are discussed below:

- (i) **Independent variables:** In any process, the variable which is manipulated or the variable whose impact is observed on another variable is called 'independent variable'. In the process of teaching, the teacher plays the role of an independent variable. He plans and organizes all activities of the classroom, and thus controls the process of teaching. The teacher is free to perform his teaching activities in order to bring about desirable outcomes from the learners. Hence, the teacher is more independent as compared to students. He has to diagnose the potential of the students and formulate educational objectives, accordingly. Thus, a teacher is a very important variable in the attainment of goals of education.
- (ii) **Dependent variables:** In any process, the variable on which the effect of an independent variable is studied is called a 'dependent variable'. In the teaching-learning process, learners or students are dependent variables as they depend upon the teacher. It is the student who is subjected to changes and development through the effort of the teacher. The student has to act according to the planning and organization of the teacher. Hence, the student is included in the category of dependent variables.
- (iii) **Intervening variables:** A variable which falls in between independent and dependent variables and may influence dependent variables is called an 'intervening variable'. Intervening variables are also very important in the process of teaching as they help in smooth functioning of independent and dependent variables, for the realization of teaching objectives. In the process of teaching-learning, contents, methods of teaching, teaching environment, management of instructional material, learner's background, student's interest, attitude, and aptitude, are some of the intervening variables. These variables are responsible for bringing about desirable interaction between the teacher and the students by producing proper teaching environment, teaching material and facilities, and creating appropriate learning conditions or situations.

Functions of variables

N. R. Swarup Saxena and S. C. Oberoi, in their book, *Technology of Teaching*, have given the following functions of variables of teaching:

(i) Diagnostic function

The diagnostic function is the first aspect of teaching. In this aspect, the teacher decides about the pupils' entering behaviour and teaching objectives. Hence, the teacher considers only two things under the diagnostic function: (a) the pupil and (b) the content. The teacher, first of all, determines the previous knowledge or basic behaviour of the pupil. He then arranges the elements of the content to be taught in a sequence, by analysing them logically. In this way, the diagnostic function is the foundation of the remedial aspect of teaching. This function is performed in accordance with the pre-active phase. In this function, the teacher takes decisions after considering the following variables:

NOTES

NOTES

- **Analysis of teaching problem:** The first variable of diagnostic aspect is analysis of the teaching problem. Hence, the teacher should decide the basic behaviour of pupils, related to the content, with far-sightedness and depth. It is also to be decided whether that content is according to their capacity or not. In other words, the teacher should take the decision concerning pupils and content so that the desired objectives may be attained. This decision proves fruitful for the remedial aspect or the interactive phase of teaching.
- **Determining the entering behaviour of students:** The second variable of the diagnostic aspect is to clearly determine the basic behaviour of students. After this, the teacher should present the new knowledge to the pupils. Its advantage is that after presenting the new knowledge, the information of changes in the behaviour of pupils will be easy to acquire. Hence, for determining the basic behaviour of pupils, the teacher should prepare and use evaluative questions, keeping in view the contents, which should be reliable and valid.
- **Individual differences:** The third variable of the diagnostic aspect is the consideration of individual differences of pupils. The principle of individual differences means that every pupil has different interests, attitudes, capacities, abilities and needs. Hence, keeping in view the capability differences of pupils, the teacher should perform the task of teaching.
- **Task analysis:** Task analysis is the fourth variable of the diagnostic aspect. The teacher should analyse learning activities related to the content. The success or failure of a lesson also depends on the task analysis.
- **Analysis of content on the basics of types of learning:** The last variable of the diagnostic aspect is analysis of the content, with regard to the type of learning. For this, the teacher should know the nature of learning. He should also know the tactics and principles to be used in various situations so that teaching becomes easy, clear, effective, understandable and scientific.

(ii) Remedial phase

In the remedial phase, an effort is made to bring desired changes in the behaviour of pupils. Hence, the teacher should make decisions regarding the use of teaching methods, strategies, tactics and mutual relationships between various variables, keeping in view individual differences of pupils. Assistance must be sought from action research in order to solve various problems which arise during the teaching. In this way, the teacher should manage the teaching variables in such a way that maximum teaching objectives are attained by deciding teaching techniques and tactics. This aspect has the following two sections:

- **Selection of teaching strategies and tactics:** The first section of teaching strategies and tactics is their selection. It should be remembered that the success of teaching and learning depends upon appropriate selection and use of teaching strategies and tactics. Hence, the teacher should perform this important function in accordance with his ability and experience.

- **Arrangement of feedback devices:** The second important section of the remedial phase is the arrangement of feedback devices. Here, it is essential to state that feedback is the soul of successful teaching. Its reason is that feedback provides reinforcement to the pupil, which in turn, provides motivation and encouragement for learning. Hence, at the time of teaching, the teacher should provide necessary feedback for motivating and encouraging the pupils.

NOTES

(iii) Evaluative phase

Evaluation is the third important variable of teaching. In this phase, the diagnostic aspect is evaluated. It should be remembered that the criterion of this evaluation is achievement of objectives. If the objectives are achieved, the remedy by the teacher is correct, otherwise it is defective. In other words, if the teaching objectives are not achieved, the teacher should not blame the pupil for his failure. He should change the variables of the diagnostic aspect so that the objectives may be achieved. Concerning this, it should be remembered that this aspect is in accordance with the post-active phase. This aspect has the following important parts:

- **Construction of criterion test:** The first part of the evaluation aspect is construction of the criterion test, which provides clear information regarding the changes brought in the behaviour of pupils by remedial teaching. The main characteristic of the criterion test is its objectivity. In other words, this test is reliable and valid. Hence, the teacher should construct the criterion test with great care.
- **Evaluation of behavioural changes:** The second part of the evaluation aspect is the evaluation of pupils' behavioural changes. The teacher should perform this function on the basis of criterion test.
- (c) **Diagnosis:** The last part of the evaluation aspect is diagnosis. Diagnosis means to know the extent of success teaching by evaluation. If it is not successful, then the teacher should decide upon the type of modification that should be brought about. If the teaching objectives have not been achieved as a result of their use, then planning, organization, leading and controlling of the teaching process should be repeated.

2.7.2 Phases of Teaching

Teaching is a complex task and systematic planning is required to make this task successful and easy. This planning has to be done in a sequence of steps. These different steps are called 'phases of teaching'. Different phases of teaching have different types of activities. There are three main phases of the process of teaching. These are as follows:

(i) Pre-active phase

This phase is also called the planning phase of teaching. As the name suggests, this phase is mainly concerned with the preparation for teaching. It involves all those activities that a teacher does before actually entering the classroom. The following activities can be included in this phase:

NOTES

- **Fixing of goals:** For any type of teaching, first of all, the teacher decides the goals, aims and objectives. After fixing the goals, the teacher decides on specific instructional objectives in the form of clearly defined behavioural terms. He also decides the level of sophistication or abstraction concerning the goals. While deciding objectives, the teacher also keeps in mind the characteristics and needs of the society.
- **Deciding the subject:** After deciding the objectives, the teacher has to decide on the subject for students. While deciding the subject matter, he needs to consider the curriculum, behaviour of learners, their needs and motivation.
- **Sequencing the elements of content for presentation:** After deciding on the subject matter, the teacher has to arrange elements of the subject matter from logical and psychological viewpoint, so that this sequencing of the subject matter may prove helpful in the transfer of knowledge.
- **Decision-making about teaching strategies:** After arranging the subject matter, the teacher has to decide the methods and techniques to be employed. The content may be imparted through lectures, group discussions or self-instructional material. The teacher will select teaching strategies, keeping in mind subject matter and level of the pupils.
- **Deployment of teaching strategies:** Now the teacher has to decide as to what strategies will be used, and how and when they will be used in the classroom. The teacher shall also decide when and how questions should be asked.

(ii) Interactive phase

This is the second phase of teaching where the actual teaching–learning takes place. Whatever has been planned or decided at the planning stage is implemented at this stage. Here, the teacher and students are actually participating in the teaching–learning process. This phase includes all activities, behaviours or things done between the time the teacher enters the classroom and the time when the lesson or subject content has been delivered by him. The interactive phase involves following activities:

- **Perception:** Appropriate perception on the part of the teacher as well as the students is a very essential element in the process of teaching. When the teacher enters the class, first of all he tries to perceive the classroom’s climate. Such perception helps him in knowing about the pupils who can prove helpful to him and those who can create problems for him. The teacher tries to weigh himself and his abilities with respect to the class group. In the same way, students also perceive the personality, behaviour and capability of the teacher in order to seek desirable interaction in the classroom.
- **Diagnosis of the learners:** It is very essential for the teacher to diagnose his abilities and behaviour and that of the students he is going to teach. The diagnosis may be done by asking questions. The students also through verbal or non-verbal interaction get the opportunity to assess and diagnose the abilities,

aptitude, interest and performance of their own responses. Thus, everyone in the classroom situation tries to see within his own self.

- **Reaction or achievement:** This is the period of actual interaction between the teacher and the students. This step involves the following activities:
 - **Selection of stimuli:** The stimuli in the action or activity of teaching can be verbal as well as non-verbal.
 - **Presentation of stimuli:** After selecting the proper stimuli, the teacher should now present that stimulus before the pupils.
 - **Feedback and reinforcement:** Feedback and reinforcement are two of the most pivotal concepts in learning. Feedback involves providing learners with information about their responses, whereas reinforcement affects the tendency to make a specific response again.
 - **Deployment of teaching strategies:** The strategies of reinforcing the students, of controlling their verbal and non-verbal behaviour, and of imparting subject matter systematically and effectively to the learner continues for most of the time while a teacher is teaching.

NOTES

(iii) Post-active phase

The post-active phase of teaching is the simplest of all phases. It is nothing but the evaluation of operations involved in teaching. This phase comprises attempts made by teachers for determining the effectiveness of their teaching, and effectiveness of lessons taught by them. Practically, the data that is collected and examined is a combination of observation of classroom activities and outcome of students' written work. This phase involves the following operations:

- **Defining the exact dimensions of teaching:** The teacher compares the expected and the actual behavioural changes in the course of his teaching, at the end of his session. The extent or quality of accomplishment of stipulated objectives helps the teacher to understand the effectiveness of teaching. It also helps in taking decisions about future improvement. Methods and strategies used by a teacher are said to be effective only if the teaching objectives have been achieved.
- **Selecting appropriate testing devices and techniques:** The teacher chooses appropriate testing techniques and evaluation tools to measure the various dimensions of behaviour. Thus, he notices the changes brought about by his teaching. The tests may be of many types, e.g., paper-pencil test, standardized tests, objective type tests, and teacher-made tests. It helps the teacher to teach things better in future and also the students to learn things better.
- **Changing strategies in terms of evidences gathered:** On the basis of assessment, a teacher comes to know about his performance. If the objectives have not been achieved, the teacher may find out the factors responsible for failure and also find the remedial techniques to be applied so that the objectives can be achieved.

NOTES

CHECK YOUR PROGRESS

- 15. What is teaching according to John Brubacher?
- 16. 'Teaching is a tri-polar process.' Name the three poles of teaching.
- 17. Why is feedback considered to be the soul of successful teaching?

2.8 TEACHING MACHINE

The pressure of the increasing population is affecting schools and teachers such that there is a higher demand of quality education and individual attention. To deal with the situation, various educationists are busy in finding the best solution for solving the problem of teaching. One of these solutions is a teaching machine, also called programmed teaching. Teaching machine is a mechanical or electronic device for self-teaching. Teaching machine is a device which is automatic in nature and is controlled by the user. It helps in presenting the information to the learner and is also able to get his response. Teaching machine acts like teacher, as the name suggested, and hence after response from the learner, it provides feedback regarding the correctness of the learner's response. The teaching machine presents the learner with a sequence of questions, problems, or instructions. The learner responds to each item, typically by pressing one of the several buttons provided to him. Teaching machines have been used in school systems and job-training programmes.

In classrooms, it is very difficult for a teacher to deal with individual differences as there are both slow and fast learners. The fast learners find the teacher slow, if he is teaching according to the speed of slow learners. Similarly, slow learners find the teacher too fast, if he is teaching according to the speed of fast learners. Teaching machine can solve the problem of individual differences as each student can learn according to his own rate. These machines are unique instructional aids because students remain active as they have to read, watch and respond, according to the content being taught. A teaching machine presents information in a carefully planned manner; generally in small steps that can be mastered easily. Mistakes are revealed immediately giving time for improvement. Subject matter presented in this way is called a programme, or programmed material.

We can thus define teaching machines as follows: 'A mechanical, electrical or other automatic device designed to teach students by presenting information in a planned sequence, questions based on the given information and providing an immediate response to his or her answer.'

An American psychologist Ludy T. Benjamin defined teaching machine as follows: 'A teaching machine is an automatic or self-controlling device that (a) presents a unit of information, (b) provides some means for the learner to respond to information, and (c) provides feedback about the correctness of the learner's response.' This definition clears the concept of teaching machines. To understand more about teaching machines we have to go through its origin and evolution.

2.8.1 History of Development of Teaching Machine

Experimentation in mechanized teaching began in the 19th century. Several kinds of devices were in use at the time of World War II. In the mid-1950s, the psychologist B. F. Skinner devised programmed materials that led to the development of several kinds of teaching machines. By early 1980s, most of these machines had been replaced by computers. The use of computers for self-teaching is known as Computer Assisted Instruction, or CAI.

However, the development of teaching machine began with the educational devices of the 19th century, through initial teaching machines of Sidney. Pressey in the 1920s to the machine invented by B. F. Skinner in 1950s. However, pioneer work is considered to be done by Pressey and thus, he is known as the father of teaching machines. Pressey's machine was strongly influenced by Thorndike and his laws. In 1924, Sidney L. Pressey made a basic teaching machine appropriate for rote-and-drill learning. In 1926, he published the first paper by using a teaching machine, for use in schools and society. Pressey showed that learning was facilitated by automated-instruction by providing immediate reinforcement, individual adjustment of pace and active responses. He had done impressive work in the world of education by providing information in a sequence and by immediate feedback, with active participation of the learner. However, at that time the world of education was not ready for this change as the study of human learning was dominated by teacher-oriented and theory-based learning.

As time passed, the use of such machines was emphasized by many educationists as well as psychologists. In 1950s, B. F. Skinner, a famous psychologist and a professor at Harvard University invented the actual teaching machine. He came up with a box-like mechanical device that fed questions to students, rewarding correct answers with fresh academic material. Wrong answers simply repeated the old question. Skinner said, 'the student quickly learns to be right'. A number of teaching machines were developed after the work of Pressey and Skinner, which had tremendous effect on the process of learning. By the mid 1960s, it was possible to identify different types of teaching machines like the linear machine, which had content in a particular sequence. Another type of teaching machine was the adaptive machine in which each learner develops mastery of the content, depending upon its capability.

Thus, we can say that the origin of teaching machine had a psychological basis. A number of teaching machines are in use nowadays. These are used by the teachers to assess the student's knowledge. They are very helpful for the teacher to increase the knowledge of individual differences and also to apprise them about the strong and weak points of their students. Teaching machines are specially used for small children as they are very successful in drilling practices.

2.8.2 Characteristics of Teaching Machine

The characteristics of teaching machine are as follows:

- A teaching machine not only presents information to the students but also elicits information from them.

NOTES

NOTES

- It keeps record of student's response. This estimates how much they have learnt.
- Teaching machine informs students about their progress by showing correct and incorrect responses. This restricts cheating.
- Teaching machine helps in solving the problems of teaching.
- Teaching machine controls the behaviour of students.

2.8.3 Constituent Parts of Teaching Machines

Teaching machines are used to teach students in such a way that they are induced to engage in new forms of behaviour. It is not only a matter of teaching them what to do but also how to do it. There are different types of teaching machines, but following are the main components that are present in every type of teaching machine:

- **Content:** It forms the most important part of a teaching machine. Content is the information stored in a teaching machine, which is to be transferred to the learner in a particular manner. Content is organized on the principles of psychology. All necessary information regarding related subject or topics is included and divided into frames, which are arranged in a particular sequence.
- **Medium of transformation:** The content prepared for a teaching machine is present in the form of programmed text, radio/TV programme or in the form of computer software. To transmit this information to students, a proper channel is required. This is known as the 'medium of transformation'. This medium could be printed words, audio-visual programme, computers or other likely devices. These mediums allow students to learn at their own pace, as they proceed from frame to frame. They can take as much time as required, according to their learning/responding ability. Thus, mastery of content can be achieved by each and every student.
- **Responding:** In each frame, there are some given questions in multiple choice format or others, depending on the type of teaching machine. Thus, after going through the content, students have to answer those questions and then only they are able to move to the next frame. Thus, response from a student tells us about what he has learnt with the help of a teaching machine.
- **Feedback:** After response from students, correct feedback is given to them so that they are able to know what they have actually learnt. If the response is correct, they are moved to the next frame, but if the response is incorrect they are given the necessary information and made to read the content, after which they can move ahead. It is very important for students to know about their progress as it is considered to be a very important component of the teaching machine.

2.8.4 Types of Teaching Machines

Teaching machines can be of various types, but all of them work on the same principle. Some teaching machines are extremely simple and easy to prepare and handle, while some are complex and not easy to prepare. So we may broadly categorize them into the following types:

- **Simple teaching machines:** In simple teaching machines, a test sheet or a book has content and questions, along with answers. For example, after the necessary information, questions are given in the form of fill in the blanks and answers are given on some other page.
- **Complex teaching machines:** In complex teaching machines, help of electronic devices like computers are taken. Here, frames are arranged in sequence and questions are of multiple choice types. The next question appears only when the user answers the previous one correctly. Otherwise, he is prompted to answer the same question again till he does it correctly.

NOTES

2.8.5 Advantages and Disadvantages of Teaching Machines

There are many advantages and disadvantages of using teaching machines. Some of them are as follows:

Advantages of teaching machines

- **Individual differences:** Teaching machines allow individual learners to proceed at their own pace and also give them the opportunity to review their work.
- **Immediate feedback:** They provide immediate feedback to learners.
- **Self instruction:** If teacher is not present, teaching machines can serve the purpose and help students to continue with the learning process.
- **Command on the subject:** They give the learner more control on the subject, as he/she can learn a lot from correct or incorrect answers.
- **Interactive:** Teaching machines normally interact directly and individually with each student and they never lose patience with students, even after a number of mistakes made by them.
- **Active participation:** Teaching machines involve a lot of participation from learners, as a result of which they remain active, unlike traditional teaching.
- **Not time bound:** Teaching machines can be used any time because they never get tired.
- **Diagnosis of problem:** While using teaching machines, a learner gets the correct answer immediately after responding to the question, so errors can be easily diagnosed.
- **Motivation:** Immediate feedback helps students to know whether they are right or wrong, and if right they are motivated to continue successfully.
- **No cheating:** Copying and cheating is discouraged in this programme. Since students perform on their own, answers are not shown to them directly.
- **For drilling:** It is very useful for the subjects where drills is required. Teaching machines are very useful for younger students who learn mostly through drills.
- **Helpful for teachers:** Teaching machines saves the teacher from a lot of drudgery resulted from drilling and routine teaching. This helps them to utilize

their energy and time saved by the machine for better and more creative type of activities and teaching.

Disadvantages of teaching machines

NOTES

The disadvantages of teaching machines are as follows:

- **Time consuming:** It is very time consuming to prepare a teaching machine.
- **Costly:** Teaching machines are very expensive. Hence, developing countries like India cannot afford to use them in their educational and training institutions, at reasonable scales.
- **Difficult:** It is difficult to develop programmes for the machine.
- **Not self-sufficient:** There are many things which students can learn only with the help of a teacher, so only teaching machines are not sufficient for learners.
- **Maintenance:** Maintenance of these machines is both difficult and costly.
- **Boring:** If a lot of errors occur in answering the questions, students may get bored or demotivated. Moreover, readymade structure of programme often fails to create curiosity or stimulate the thinking ability of a learner.
- **Lack of flexibility:** There is loss of human touch and lively interaction in the learning process organized by means of teaching machine. This leads to lack of flexibility and interest in the system and fails to promote effective learning.

CHECK YOUR PROGRESS

18. What is a teaching machine?
19. Who is considered to be the father of teaching machines?
20. What is a simple teaching machine?

2.9 SUMMARY

- Man is a social animal and his ability to communicate is the prime factor that distinguishes him from other animals. Apart from basic necessities, one needs to be equipped with good communication skills.
- According to John Hoben, 'communication is the verbal interchange of thoughts or ideas'.
- Communication is a complex process which involves various steps. A number of barriers can hinder this process at both ends (sender and receiver).
- The process of communication consists of a message being sent and received. The effectiveness of communication can be estimated by the similarity between the message sent and the one received.
- The process of interpretation of the information that is transferred is known as 'decoding'. Decoding is done by the receiver.

- Appropriate feedback from receiving end conveys that the message of the sender has been received and interpreted correctly. The feedback can also work in reverse order from the source to the receiver's end.
- The basic units of any language are words and sentences which are governed by the rules of the grammar. Language can make use of one of the three forms: (i) oral, (ii) written (iii) oral and written.
- Our body has an impressive and effective language for communicating our feelings, thoughts and actions.
- The quality and effectiveness of the process of communication is affected favourably or adversely through the presence of some other intervening variables lying between the source of communication and the receiver.
- Sometimes obstructions are confronted in communication, as a result of which the transmitted message either goes wrong or received incompletely. Sometimes, communication relations are broken down.
- The beginnings of the classroom observation research can be traced back to the initial years of the second decade of the 20th century
- Assessable studies usually recognize the target behaviour before the observation and hence prepare a checklist or a kind of schedule which is then made use as tools in classroom settings to record or measure the intensity of occurrence of the recognized behaviour.
- Besides the source and the target, the SCIS also classifies the interactions between the teacher and student with respect to their type, object, outcome and feedback.
- Almost all the research carried out in the field of the role of the teacher is related to the all-pervasive, social-emotional atmosphere termed as 'classroom climate'.
- Interaction analysis is that verifiable observation which provides the best foundation for systematic knowledge of the teaching-learning process in the classroom.
- There are different ways to interpret this interaction matrix. The simplest way of interpreting the interaction data is to convert behaviour in terms of percentages, which explain the use of various categories by a teacher during classroom interaction.
- Teaching is considered to be a social phenomenon. Teaching is an art in which a teacher influences his students and motivates them for learning.
- The diagnostic function is the first aspect of teaching. In this aspect, the teacher decides about the pupils' entering behaviour and teaching objectives.
- Teaching machine is a mechanical or electronic device for self-teaching. Teaching machine is a device which is automatic in nature and is controlled by the user. It helps in presenting the information to the learner and is also able to get his response.

NOTES

NOTES

- The development of teaching machine began with the educational devices of the 19th century, through initial teaching machines of Sidney Pressey in the 1920s to the machine invented by B. F. Skinner in 1950s.
- In simple teaching machines, a test sheet or a book has content and questions, along with answers. For example, after the necessary information, questions are given in the form of fill in the blanks and answers are given on some other page.

2.10 KEY TERMS

- **Communicare:** Process of transmitting information and understanding is known as communicate.
- **Sender:** A sender is a person who initiates communication by making use of language or symbols to convey the message.
- **Message:** A message is a key idea, thought, opinion, feeling, knowledge or information, which sender wants to communicate.
- **Decoding:** The process of interpretation of the information that is transferred is known as decoding.
- **Proxemics:** Proxemics is the study of perceptions of people on physical space and its use by them.
- **Chronemics:** Chronemics studies the use of time in non-verbal communication.
- **Chronic absentee:** If an individual is frequently absent, he or she is called chronic absentee.
- **Paralanguage:** Also referred to as *vocalics*, paralanguage is the study of non-verbal cues of the voice.
- **Haptics:** The study of touching behaviour as non-verbal communication is known as haptics.
- **Oculesics:** Oculesics refers to the role of eyes in non-verbal communication.
- **Kinesics:** The study of body movements, facial expressions and gestures is called kinesics.
- **Interaction analysis:** Interaction analysis is basically a process of encoding and decoding the teaching and learning pattern.
- **Teaching:** 'Teaching is an arrangement and manipulation of a situation, in which there are gaps or obstructions which an individual will seek to overcome.'
- **Independent variables:** In any process, the variable which is manipulated or the variable whose impact is observed on another variable is called 'independent variable'.
- **Dependent variables:** In any process, the variable on which the effect of an independent variable is studied is called a 'dependent variable'.

- **Intervening variables:** A variable which falls in between independent and dependent variables and may influence dependent variables is called an 'intervening variable'.
- **Teaching machine:** Teaching machine is 'a mechanical, electrical or other automatic device designed to teach students by presenting information in a planned sequence, questions based on the given information and providing an immediate response to his or her answer.'

NOTES

2.11 ANSWERS TO 'CHECK YOUR PROGRESS'

1. Communication, derived from the Latin word '*communicare*' which means 'to share', is the process of transmitting information and understanding.
2. Communication plays a vital role in building relationships between people. It facilitates dialogue, exchange of expression and emotions which result in relationships. The type of communication decides the relation. It could be personal or professional.
3. The process of interpretation of the information that is transferred is known as 'decoding'. Decoding is done by the receiver.
4. The basic units of any language are words and sentences which are governed by the rules of the grammar.
5. Chronemics studies the use of time in non-verbal communication. Time is an important determinant of a person's image.
6. Ray L. Birdwhistell, a ballet dancer who later on became an anthropologist, advanced this concept in the 1950s.
7. The quality and effectiveness of the process of communication is affected favourably or adversely through the presence of some other intervening variables lying between the source of communication and the receiver.
8. Barriers of communication can be classified into three types:
 - Barriers related to message-sender
 - Barriers related to message transmission
 - Barriers related to message-receiver
9. A word may have several meanings. Therefore, the use of word should be clear as to its context and place, else there may be misunderstanding.
10. The beginnings of the classroom observation research can be traced back to the initial years of the second decade of the 20th century.
11. Observation may be of the following types: direct and indirect, natural and artificial, scheduled and unscheduled, participant and non-participant.
12. Basically, interaction analysis has been used to help quantify a teacher's verbal behaviour. It provides an idea about the process going on inside the classroom in terms of teaching and learning.

NOTES

13. There are different ways to interpret this interaction matrix. The simplest way of interpreting the interaction data is to convert behaviour in terms of percentages, which explain the use of various categories by a teacher during classroom interaction.
14. The advantages of Flanders' Interaction Analysis are:
 - It is a useful means of identifying, studying, classifying and measuring specific variables, as they interact within instructional learning situation.
 - With the help of the interaction matrix, a clear picture of the occurrences of the classroom can be drawn, even in the absence of the observer.
15. According to John Brubacher, 'Teaching is an arrangement and manipulation of a situation, in which there are gaps or obstructions which an individual will seek to overcome.'
16. Teaching is a tri-polar process and its three poles are: teaching objectives, learning experiences and behaviour modifications.
17. It is essential to state that feedback is the soul of successful teaching. Its reason is that feedback provides reinforcement to the pupil, which in turn, provides motivation and encouragement for learning.
18. Teaching machine is a mechanical or electronic device for self-teaching. Teaching machine is a device which is automatic in nature and is controlled by the user. It helps in presenting the information to the learner and is also able to get his response.
19. Sidney L. Pressey is considered to be the father of teaching machines.
20. In simple teaching machines, a test sheet or a book has content and questions, along with answers. For example, after the necessary information, questions are given in the form of fill in the blanks and answers are given on some other page.

2.12 QUESTIONS AND EXERCISES

Short-Answer Questions

1. What is communication?
2. List the characteristics of communication.
3. Write a note on the importance of communication.
4. How is listening an integral part of communication?
5. What constitutes verbal communication?
6. What are the important modes of non-verbal communication?
7. How is body language an important source of communication?
8. What are the barriers to communication?
9. What is the Structured Classroom Interactions Schedule (SCIS)?
10. State the importance of observation.

11. How is the process of interaction analysis carried out?
12. List the disadvantages of Flanders' Interaction Analysis.
13. What is teaching? What are its characteristics?
14. Write a note on the various phases of teaching.
15. What are the types of teaching machines?
16. Write a short note on the history of development of a teaching machine.

NOTES

Long-Answer Questions

1. 'The process of communication consists of a message being sent and received'. Discuss the concept and significance of communication with reference to the given statement.
2. 'Communication can be of two types—verbal and non-verbal.' Explain the types of classroom communication in detail.
3. Assess the factors affecting classroom communication.
4. Critically analyse the observation schedules of classroom interaction.
5. Evaluate the Flanders' Interaction Analysis as a tool for enhancing the teacher-learning process.
6. Critically analyse the process of teaching, its variables and phases.
7. Discuss the teaching machine as a tool for enhancing the process of teaching.

2.13 FURTHER READING

- Aggarwal, J. C. 2009. *Essentials of Educational Technology*. New Delhi: Vikas Publishing House.
- Kochhar, S. K. 1985. *Methods and Techniques of Teaching*. New Delhi: Sterling Publishers.
- Mangal, S. K. 2001. *Foundation of Educational Technology*. Ludhiana: Tendon Publications.
- Sampath, K., A. Panneerselvam, S. Santhanam. 2007. *Introduction to Educational Technology*. New Delhi: Sterling Publishers.
- Shankala, D.P. 2006. *Educational Technology*. New Delhi: Adhyayan Publishers and Distributors.
- Sharma, K. K. 2007. *Educational Technology*. Delhi: Mahaveer & Sons Publishers and Distributors.
- Sharma, R. A. 2002. *Technology of Teaching*. Meerut: International Publishing House.

UNIT 3 MICROTEACHING

Structure

- 3.0 Introduction
- 3.1 Unit Objectives
- 3.2 Microteaching—Definition, Skills Involved in Microteaching
 - 3.2.1 Phases of Microteaching Procedure
 - 3.2.2 Microteaching Cycle
 - 3.2.3 Indian Model of Microteaching
 - 3.2.4 Teaching Skills Through Microteaching
 - 3.2.5 Advantages of Microteaching
 - 3.2.6 Disadvantages of Microteaching
- 3.3 Teaching Model
 - 3.3.1 Nature of Teaching Models
 - 3.3.2 Elements of a Teaching Model
 - 3.3.3 Types of Modern Teaching Models
 - 3.3.4 Glaser Model of Teaching or Basic Teaching Model
 - 3.3.5 Classroom Meeting Model
 - 3.3.6 Uses and Limitations of Teaching Models
- 3.4 Information Processing Models
 - 3.4.1 Models and Theories
- 3.5 Simulated Teaching
 - 3.5.1 Objectives of Simulated Teaching
 - 3.5.2 Educational Uses of Simulation
 - 3.5.3 Types of Simulation
 - 3.5.4 Procedure of Simulated Teaching
 - 3.5.5 Teacher Training and Simulated Teaching
 - 3.5.6 Precautions in Simulated Teaching
 - 3.5.7 Advantages of Simulated Teaching
 - 3.5.8 Disadvantages of Simulated Teaching
- 3.6 Summary
- 3.7 Key Terms
- 3.8 Answers to ‘Check Your Progress’
- 3.9 Questions and Exercises
- 3.10 Further Reading

NOTES

3.0 INTRODUCTION

Teaching behaviour refers to the behaviour demonstrated by a teacher at the time of carrying out teaching activities in the classroom. A teacher’s behaviour is exhibited through skills used by him or her in a classroom. These skills are known as ‘teaching skills’.

Microteaching is a brilliant method for developing aptitude and self-confidence to experience a variety of lecturing/tutoring approaches, and become skilled at providing constructive feedback. It offers instructors with an opportunity to safely let themselves be scrutinized by a small group audience. They can also scrutinize and comment on other people’s performances. In order to prepare teachers,

NOTES

microteaching trainings are supported by video-recordings. In a sheltered atmosphere of friends and colleagues, it is easy for teachers to practice what they usually do with their students and get expected positive feedback. A microteaching session is an opportunity to take on new teaching and learning strategies, and a student learns about their requirements and expectations. It facilitates learning from others and enriches one's own teaching methods.

Educationists and psychologists have always strived to improve the teaching techniques. Various models have been developed to provide teachers with a wide range of approaches for creating an environment of interactive learning. An intelligent use of these approaches will allow teachers to understand better the students' learning needs, improvise the different learning styles, and design appropriate curriculum and educational activities. The models of teaching are, in fact, implementation of practical problems and looking for their solutions as student and teachers work together in a classroom. These are scientific and systematic approaches. Some of these models are simple to use but difficult to master while some serve broad purposes and others target particular goals. In this unit, you will learn about the concept of microteaching, the skills involved in microteaching, nature and elements of teaching models, Robert's Glaser's model of teaching and William Glasser's classroom meeting model. You will also learn about the use of information-processing models promoted by cognitive psychologists and simulated teaching.

3.1 UNIT OBJECTIVES

After going through this unit, you will be able to:

- Discuss the concept of microteaching
- Analyse the skills involved in microteaching
- Assess the concept, types, uses and limitations of models of teaching
- Discuss the various theories of information-processing models
- Explain the types, advantages and disadvantages of simulated teaching

3.2 MICROTEACHING—DEFINITION, SKILLS INVOLVED IN MICROTEACHING

A trainee teacher is bewildered by the complexity of teaching a large class of students and finds it very difficult to learn all the aspects of teaching at the same time. It is easier for him to practice and learn one skill of teaching at a time. This problem was resolved by a process of training teachers in practical teaching. It came to be known as Microteaching. Microteaching is an excellent way of helping teachers and student-teachers to understand the process of teaching and learning better. It provides constructive feedback which helps teachers scrutinize their own teaching in order to discover their strengths and weaknesses. As a tool for teacher preparation, microteaching trains teaching behaviours and skills in small group settings, aided by video-recordings. Microteaching is a kind of real teaching reduced in time, number

of students and range of activities. It provides teachers with ample opportunities to explore and reflect on their own and others' teaching styles and to acquire new teaching techniques.

The history of microteaching goes back to the mid-1960s, when Dwight Allen and his colleagues from the Stanford University developed a training programme. This programme was aimed at improving verbal and non-verbal skills and general performance of teachers. The Stanford model had a three-step approach using actual students as authentic audience. The model was first applied to the teaching of science, but later it was introduced to language teaching. A very similar model called Instructional Skills Workshop (ISW) was developed in Canada during the early 1970s. It was a training support programme for college and institute faculty. Both these models were designed to enhance teaching and promote open collegial discussion about teaching performance.

NOTES

Definitions of Microteaching

Microteaching had been defined in different ways as follows:

- **D. W. Allen (1966):** Microteaching is a scaled down teaching encounter in class size and time.
- **R. N. Bush (1968):** Microteaching is a teacher education technique, which allow teachers to apply clearly defined teaching skills in carefully prepared lessons, in a planned series of 5–10 minute encounters with a small group of real students, often with an opportunity to observe the result on video tape.
- **Clift and others (1976):** Microteaching is a teacher training procedure which reduces the teaching situation to a simple and more controlled encounter achieved by limiting the practice of teaching to a specific skill and reducing teaching time and class size.
- **L. C. Singh (1977):** Microteaching is a scaled down teaching encounter in which a teacher teaches a small unit to a group of five students for a short period of five 5–20 minutes. Such a situation offers a helpful setting for an experienced or inexperienced teacher to acquire new teaching skills and refine old ones.
- **N. K. Jangira and Ajit Singh (1982):** Microteaching is a training setting for the learning teacher, where complexities of the normal classroom teaching are reduced by: practising one component skill at a time, limiting the content to a single concept, reducing the size to 5–10 students, and reducing the duration of lesson to 5–10 minutes.

Characteristics of Microteaching

The characteristics of microteaching are as follows:

- Microteaching is an experiment in the field of teacher education, which has been incorporated in the practice teaching schedule.
- Microteaching is a highly individualized training device.

NOTES

- It is a student teaching skill training technique and not a teaching technique or method.
- The main objective of the microteaching session is to provide participants with an environment for practice-based teaching, to instil self-evaluative skills.
- Microteaching is a scaled down teaching encounter, which reduces the complexities of real teaching such as:
 - o practising one skill at a time
 - o reducing the class size to 5–10 students
 - o reducing duration of the lesson to 5–20 minutes
 - o limiting the content to a single concept
- Students are provided with immediate feedback that helps in improving and motivating learning.

Assumptions of Microteaching

Some of the important assumptions underlying the process of microteaching are as follows:

- Teaching is a complex process, but can be analysed into simple skills.
- Teaching skills can be practised one by one up to a level of mastery, under specific and simplified situation.
- Appropriate feedback, if systematically given, proves very significant in mastering each skill.
- When all skills have been mastered, they can be integrated for real classroom teaching.
- Skill training can be conveniently transferred from simulated teaching situation to actual classroom teaching situation.

Objectives of introducing microteaching in colleges

Duggal and Sharma have listed the following objectives of introducing microteaching in colleges:

- To initiate trainee teachers to analyse and develop teaching behaviour under laboratory conditions
- To land novice teachers gradually in the real classroom after gaining enough confidence
- To impart intensive training in the component skills of teaching to teacher trainees at pre-service level
- To involve the academic potential of teacher trainees for providing feedback to peers
- To lessen the workload of teacher educators with the involvement of peer supervisors

- To lessen the burden on practising schools
- To explore human resources and economy to the maximum with respect to time, money and materials

3.2.1 Phases of Microteaching Procedure

Microteaching involves the following three phases as suggested by Cliff and others (1976):

- (i) **Knowledge acquisition phase:** In this phase, the student-teacher familiarizes himself with the component of teaching skill, which he is to practice. For this he learns the skill, its rationale, its component behaviour and its role in the classroom. This can be done by reading the relevant literature, observing demonstrations, and analysing the skill. All these activities are directed to the modelling component of microteaching. Modelling can be defined as the mode of presentation of the skill.
- (ii) **Skill acquisition phase:** On the basis of the model presented, a student-teacher plans a micro-lesson for practising the demonstrated teaching skill and carries out microteaching till he acquires the desired level of mastery. This phase includes two components—feedback and microteaching setting. On the basis of classroom performance of the student-teacher, feedback is provided in order to modify the classroom performance. The setting component covers conditions like size of the micro class, duration of micro class, and type of supervision.
- (iii) **Transfer phase of microteaching:** Here, the student-teacher undertakes exercises for smoother transition from microteaching situation to real classroom situation. The component of this phase is integration of component teaching skills.

3.2.2 Microteaching Cycle

The six steps generally involved in microteaching cycle are: (i) plan, (ii) teach, (iii) feedback, (iv) re-plan, (v) re-teach and (vi) re-feedback. There can be variations as per the requirement of the objective of practice session. These steps are diagrammatically represented Figure 3.1.

- **Plan:** This involves selection of the topic and related content of such a nature, in which the use of components of the skill under practice may be made easily and conveniently. The topic is analysed into different activities of the teacher and the students. Activities are planned in a logical sequence where maximum application of the components of a skill is possible.

NOTES

NOTES

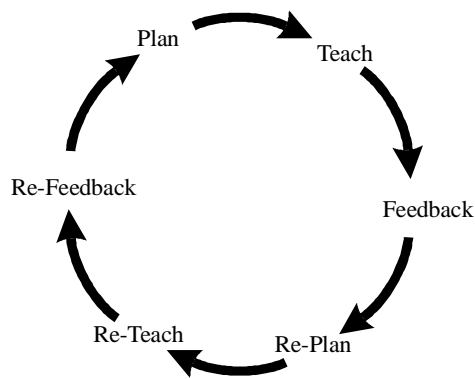

Fig. 3.1 Microteaching Cycle

- **Teach:** This involves the attempts made by the teacher trainee to use components of the skill in suitable situations, occurring in the process of teaching. If the situation is different and not as visualized, the teacher should modify his behaviour as per the demand of the situation in the class. The teacher should have the courage and confidence to handle the situation arising in the class effectively.
 - **Feedback:** This term refers to giving information to the teacher-trainee about his performance. The information includes strength as well as weaknesses related to his performance. This helps the teacher-trainee to improve upon his performance in the desired direction.
 - **Re-plan:** The teacher-trainee re-plans his lesson, incorporating the points of strength, and removing the points not skillfully handled in the previous attempt.
 - **Re-teach:** This involves teaching the same group of students, if the topic is changed, or a different group of students, if the topic is the same. This is done to remove boredom or monotony of the student. The teacher-trainee teaches the class with renewed courage and confidence to perform better than the previous attempt.
- (vi) **Re-feedback:** This is the most important component of microteaching for behaviour modification of teacher-trainee in each and every skill practice.

3.2.3 Indian Model of Microteaching

After several years of research and experimentation in microteaching, National Council of Educational Research and Training (NCERT) concluded that microteaching can be practised effectively in India without using any hardware, since symbolic and live modelling and verbal feedback have been found to be quite effective. Further, it is not necessary to use school students for microteaching; peers can act as students which has also been found to be very effective in bringing about improvement in the skill of teaching. NCERT has proposed the Indian model of microteaching, which has the following salient features:

- The mode of presentation of theory and modelling is generally done through written material, lectures, demonstrations and discussions and not through electronic gadgets like VCR, audio-tapes and films. Teacher educators give

model lessons on various teaching skills. However, with the increased availability and use of video-camera, new technology in the use of CD for modelling and feedback purposes has been suggested.

- Live observers are used to observe teaching and for providing immediate feedback to student-teachers. Teacher educator and peers participate in feedback sessions.
- College-based teaching practice is organized under simulated conditions. Peers are used as students instead of real students. Training in role playing is given to student-teachers.
- The microteaching laboratory can function with minimum facilities according to the available space, material and equipment.
- The duration of microteaching cycle is:
 - Teach : 6 Minutes
 - Feedback : 6 Minutes
 - Re-plan : 12 Minutes
 - Re-teach : 6 Minutes
 - Re-feedback : 6 Minutes
- Two half cycle lessons are also practised instead of one full cycle. The Indian model has been successfully tried out, and is being used in many universities and teacher education institutions in the country.

NOTES

Table 3.1 Comparison between Microteaching and Traditional Teaching

Microteaching	Traditional Teaching
Teaching is relatively simple.	Teaching is comparatively complicated and difficult.
The number of students is less. A class consists of a small group of 5–10 students.	The number of students is much more; a class usually has more than 40 students.
There is provision of immediate feedback, which helps the teacher know his drawbacks.	There is no provision of immediate feedback.
The teaching time is 5–10 minutes.	The duration of traditional teaching is 40–45 minutes.
The student-teacher practises only one skill at a time.	The student-teacher practises a combination of skills.
In microteaching, the role of a supervisor is specific and definite.	The role of a supervisor is quite vague in the case of traditional teaching.
The patterns of classroom interaction can be studied objectively.	The patterns of classroom interaction cannot be studied objectively.
Microteaching is done in fully controlled conditions.	This teaching does not take place in controlled conditions.

3.2.4 Teaching Skills through Microteaching

NOTES

We know that microteaching is a controlled practice which makes it possible to concentrate on a specific teaching behaviour. Competence is acquired in one skill before proceeding to another skill. Microteaching can be practised only after a teacher's behaviour has been analysed and specific skills of teaching have been identified. A teaching skill is a set of interrelated components of teaching behaviour for realization of specific instructional objectives (Jangira *et al.*, 1982). Allen and associates (1967), at Stanford University identified a set of 14 skills of teaching. In India, B. K. Passi and associates (1974) working at the Centre for Advanced Studies in Education at M. S. University, Baroda, identified 21 skills of teaching. Some of the important skills of teaching have been explained below.

- **Skill of stimulus variation:** Skills of stimulus variation are used to bring desirable changes of variation in the stimuli used to secure and sustain student's attention towards classroom activities. Some of the things a student-teacher is trained in are the use of movement in a systematic way, use of gestures, development of verbal and non-verbal methods of focusing children's attention, systematic use of pauses, and controlled use of sensory channels by switching primary modes of communication. This skill helps to increase active participation, enthusiasm and spirit of study.
- **Skill of introducing the lesson:** This skill is mainly concerned with the establishment of rapport between teacher and students for involving students in the lesson. The main components of this skill are utilization of previous experience and appropriate devices, maintenance of continuity in main parts of the introduction and relevancy of verbal and non-verbal behaviour.
- **Skill of explaining:** Explanation is the use of interrelated facts, concepts with a view to develop understanding among the students towards the content under study. In order to become an effective explainer in the classroom, the teacher should practise more.
- **Skill of reinforcement:** Every responding student of the class needs social approval of his behaviour. To satisfy this need, he is always eager to answer each question known to him. If the teacher encourages students, their participation in the class is maximized. The main purpose of the skill is to increase student participation, facilitate learning, motivate the learner, modify undesirable behaviour and develop desired behaviour.
- **Skill of questioning:** Questions are helpful in stimulating thinking and hence, significantly contribute in classroom teaching. It helps a teacher in gaining knowledge about previous awareness and entry behaviour of students, their interest and attitude towards the subject and the topic in hand. Adequate questioning skills may help the teacher in carrying out effective interaction with his students, including motivation and drawing their attention towards teaching.
- **Skill of lecturing:** This skill is concerned with effective presentation of the content. The teacher leaves his impression by using many techniques and tactics through this skill. Sometimes, it is also known as communication skill.

- **Skill of illustrating with examples:** This skill is mainly concerned with the selection of examples relevant to the concept so that the content under study may be clear and understandable to students. Examples contribute significantly in the teaching–learning process and are helpful in sustaining the attention of students.
- **Skill of classroom management:** Skill of management involves efforts made by the teacher to compel a child to participate actively in classroom activities. In this skill, the teacher supervises the activities of students, sets norms for their classroom behaviour, and asks questions.
- **Skill of using audio-visual aids:** Audio-visual aids attract and hold attention of students and makes teaching more interesting and effective. Use of these aids breaks the monotony of ordinary instructions, helps in forming the right mental images, stimulates critical thinking, and increases the power of retention.
- **Skill of using blackboard:** Blackboard is a very essential component of teaching–learning process. It is a cheap device and plays a very important role in attracting the attention of students. The skill of blackboard writing requires neatness, appropriateness of written work, simplicity and brevity in the points presented, and legibility.
- **Skill of closure:** Closure is attained when major purposes, principles and constructs of a lesson or portion of the lesson have been learnt and the students are able to relate new knowledge to the past. It is more than a quick summary of the portions covered.

NOTES

Some Important Skills of Microteaching

(a) Skill of stimulus variation

The main aim of teaching is to bring a desirable change in behaviour of students. A teacher should always try to make lessons more effective. For this, he should use various methods and techniques. He should present multiple stimuli just to gain the attention of students. In these stimuli, the teacher should himself function as a stimulus, in the form of gestures, movement of the body, change in pitch of voice, change in interaction style, pausing and sequencing of different aids of teaching. All these aspects act as stimuli in the class. The use of these stimuli during teaching is known as ‘skill of stimuli variation’.

Following are the main component of stimulus variation skill:

- **Body movements:** Body movements of the teacher play an important role in the class. Body movements should be in balance because their excessive use may distract students and similarly less body movement will make the teacher look like a dull statue.
- **Gesture:** Gestures play a very important role in making the lesson effective. These include facial expression like laughing, raising eyebrows, emotions, some other gestures like movement of eyes, nodding, movement of hands also play a significant role in drawing the attention of students.

NOTES

- **Change in pitch of voice:** The students feel boredom due to the teacher's speech at the same pitch, and they also get distracted from the lesson being taught. Thus, the teacher should bring about a change in his voice. Too high or too low pitch should be avoided. Important points should be stressed by changing the pitch of voice.
- **Focusing:** It is very important to stress on some specific points or events. This process of focusing includes verbal focusing, gesture focusing and oral-gesture focusing. Verbal focusing draws the attention of student by using and repeating certain words. Gesture focusing draws their attention by pointing fingers at written words or pictures. In some situations, the teacher uses both of them simultaneously.
- **Change in the style of interaction:** In a classroom, interaction between students and teacher is a must otherwise the classroom environment will become monotonous. But this interaction should be different. It can be between a teacher and the whole class, a teacher and a student or between students. All these types of interactions can be arranged by teachers. A teacher should ask questions in an interactive manner so that his class becomes more interesting and effective.
- **Change in teaching aids:** Different types of teaching aids should be used by the teacher while teaching. This will maintain the concentration of students towards the teacher. He should also use audio and visual aids alternatively.
- **Pause:** The teacher should continue talking in class endlessly. There should be regular pauses during the process of explanation in the class. If the teacher speaks continuously, students would get bored. Hence, pauses are important to gain continuous attention of students.

Thus, we can easily generalize that skill of stimulus variation plays a significant role in teaching, and is utilized by the teacher to make his teaching effective as well as interesting.

(b) Skill of explaining

Explaining concepts is very important in classroom teaching. Hence, a teacher has to learn the skill of explaining in order to make students understand many ideas, concepts or principles that need explanation. Explanation is nothing but a few interrelated appropriate statements.

The skill of explanation can be developed by using the following components:

- **Appropriate statement:** During a lecture, the statements used should be appropriate. The beginning statements prepare the student mentally to receive the explanation. On the other hand, concluding statements are made after the end of explanation. Both are important and should be appropriate.
- **Explaining links:** Explaining links in the form of words and phrases are meant for establishing continuity of statements used for explaining a concept, phenomena or principle. Some of these are: hence, therefore, since, because, as a result of, due to.

NOTES

- **Covering essential points:** The explanation given for understanding a given concept or principle should be as complete as possible. The completeness is determined by the scope of concept or principle as specified in the instructional objectives. It should cover all essential points leading to a clear understanding of the desired concept or principle.
- **Fluency in language:** For explaining, the teacher should speak fluently. The fluency should be such that a student may listen and understand the ideas of the teacher easily.
- **Testing the student:** While explaining, questions should be put across to students for their clarity and understanding.

Precautions for skill of explaining are as follows:

- The explanation should not include irrelevant statements.
- It should be in simple language which students can easily understand.
- It should be in a proper sequence.
- The teacher should not stammer; his language should be fluent and continuous.
- Use of inappropriate vocabulary, vague words and phrases should be avoided.

(c) Skill of reinforcement

Reinforcement denotes an event that influences the probability of a response to a stimulus being produced under similar conditions. It belongs to the psychology of learning. It is of two types: positive and negative. Use of positive reinforcement contributes towards strengthening the desirable response or behaviour and use of negative reinforcement contributes towards eliminating undesirable responses.

Following are the main components of skill of reinforcement:

- **Positive verbal reinforcement:** The teacher uses the accepting statements in order to make the learning of the students permanent such as 'I understand what you mean', 'you should express yourself'. In this way, the suggestions of student and use of encouraging language are supported.
- **Positive non-verbal reinforcement:** Sometimes, the teacher uses non-verbal cues to encourage students in the class such as smiling, nodding, listening carefully, or writing the correct answer given by a student on the blackboard. All these acts are positive non-verbal reinforcements.
- **Negative verbal reinforcement:** Sometimes, it is necessary to remove some stimuli in order to make the learning permanent. Words like: 'wrong', 'absurd' or 'I do not like your statements' may look like criticism to the student.
- **Negative non-verbal reinforcement:** On some occasions, a teacher uses negative non-verbal reinforcements like angry glares, threat of a slap. Such negative non-verbal reinforcements too should be avoided.

NOTES

Precautions for skill of reinforcement are as follows:

- Same words or statements should not be repeated again and again. There should be a variety of words.
- Excessive use of reinforcement should be avoided. It may remove its effectiveness.
- It should be used for all the students and not only for the intelligent ones.
- Appropriate words and statements should be used.
- While using reinforcement for one student, it should be kept in mind that other student should not feel inferior because of the statement made.

(d) Skill of questioning

The process of asking questions during classroom teaching is considered to be the most important part of teaching. It makes students more thoughtful and they become able to understand the depth of the subject. Various aspects are studied by asking questions. It makes the student active and alert in the ongoing process of teaching. It also helps a teacher in gaining knowledge about previous awareness and entry behaviour of students, their interest and attitude towards the subject, and the topic in hand. Adequate questioning skills may help a teacher in effectively interacting with his students.

Following are the main components of the skill of questioning:

- **Quality of questions:** Questions can serve the required purpose only when they are framed with care by the teacher. So the following points should be kept in mind while asking questions:
 - o *Relevant:* The questions asked should be relevant to the topic being taught. Irrelevant questions may confuse the students and hinder the process of teaching-learning.
 - o *Clarity:* The questions should be asked in a simple and clear language.
 - o *Specificity:* The questions asked should be specific and to the point.
 - o *Grammatically correct:* The framed questions should be grammatically correct, otherwise the students will not be able to understand them.
- **Presenting questions in class:** A teacher should try to ask questions in a clear and audible voice, accent, tone and pitch. Moreover, the speed of asking questions should not be too fast or too slow, and enough time should be given to the students for answering.
- **Involvement of all students:** Questions should be addressed to all students in a class, rather than one individual student. A teacher should include all students for answering questions so that all of them are attentive and alert during the class.

- **Behaviour of teacher:** The behaviour of the teacher should be natural while asking questions. There should be patience and sweetness in the voice and style of asking questions.
- **Prompting:** When a student expresses his inability to answer a question, the teacher can give clues to help him recall what he learnt.

In this way, proper art of asking question along with proper behaviour and presentation can help teachers in learning and acquiring the skill of questioning for bringing effectiveness to their classroom teaching. However, acquisition of this skill requires a lot of practice on the part of the teacher through microteaching.

Precautions during the use the skill of questioning are as follows:

- Questions should not be irrelevant or confusing.
- A teacher should not ask questions to a handful of students.
- The teacher should wait patiently for a student to answer until he accepts that he does not know the answer.
- While asking questions, the teacher should show pleasant behaviour.
- He should not criticize the student, if the given answer is wrong.

(e) Skill of introducing the lesson

This skill is concerned with the art of initiating the lesson. If the lesson starts properly, it proceeds smoothly and the teacher is successful and effective. The utilization of previous experience and maintenance of continuity in the main parts of introduction are the major points to remember, while using introductory skills in teaching. Following are the main components which are utilized in the skill of introduction:

- **Use of previous knowledge:** One cannot teach in vacuum. So before starting a lesson, it is essential to know the previous knowledge of students. The new learning is thus based on previous knowledge or experience acquired by students.
- **Maintenance of continuity:** Proper introduction requires continuity in ideas presented to students. There should be a logical sequence between main parts of the introduction. One activity by the teacher should lead the to other related one in a chain of continuity creating the need to study the lesson.
- **Objectives and aids:** It is also necessary to select various teaching aids, keeping in mind the objectives of the lesson. The student feels bored as a result of monotonous teaching. Disinterest develops in the student. A proper selection of audio-visual devices creates life in the introduction of the lesson and the student begins to show interest. The teacher can use various means like questioning, lecturing and storytelling. However, selection of the method should be according to the maturity level of students.
- **Duration of introduction:** The introduction of the lesson should neither be too long nor too short. The duration of introduction should arouse the interest of students.

NOTES

- **Capability of teacher:** The teacher should have the capability to create interest and motivation in students, without which they shall not show interest in the lesson.

NOTES

(f) Skill of illustration with examples

This skill is mainly concerned with the selection of examples relevant to the concept. Examples contribute significantly in the teaching–learning process and are helpful in sustaining the attention of students.

Components of the skill of illustration with examples:

- **Use of media for examples:** These examples are conveyed to the students through media. For illustration, basically two types of media are used: non-verbal and verbal. Non-verbal media includes flowers, models, pictures, plant, and videos. On the other hand, when a teacher explains everything verbally by making use of words and thoughts, it is called ‘verbal medium’. It is used most commonly by teachers in classrooms. The subject matter is made more interesting by giving examples of daily life. The teacher may draw pictures on blackboard and then explain the concept more clearly. Sometimes, a teacher may use the method of storytelling for making the teaching–learning process more effective.
- **Inductive-deductive approach:** It is very important to understand the concept first and then use it. While the former can be properly realized through inductive approach, the deductive approach helps in the latter. The task of illustrating with example requires the use of both approaches; hence a teacher should learn to use both inductive and deductive approaches for development of the skill.
- **Proper examples:** Various types of examples are used by teachers in classrooms, but while using these examples some points should be kept in mind like:
 - o Examples should be relevant to the concept or principle being explained.
 - o Examples used should be simple, based on the student’s past experience and according to the maturity level of students.
 - o An example should be interesting so that it could maintain the attention, interest and curiosity of students for better understanding.
 - o Whether a teacher is giving interesting examples or not can be judged through the overt behaviour of students and overall classroom environment.

Precautions while using skill of illustration with examples:

- The objectives of the lesson being taught should be kept in mind while using this skill.
- The illustration used should be related to the main concept or idea.
- The examples used should be according to the maturity level of students.
- Multiple media should be used for explaining the concept.

- Examples used by teacher should be interesting and motivating so that students pay attention.

3.2.5 Advantages of Microteaching

Microteaching is very helpful for making the process of teaching more effective and successful. Here are some advantages of microteaching:

- Microteaching it enables teachers to focus on certain areas of teaching and to view them from different perspectives.
- Microteaching it increases training-effectiveness using a scaled down teaching simulation environment, which reduces the complexities of normal classroom teaching and eliminates the pressure resulting from real classroom settings.
- One major advantage of microteaching is the provision of immediate feedback to bring improvement in the teacher's behaviour.
- The main objective of microteaching session is to provide the participants with an environment for practice-based teaching to instil self-evaluative skills.
- It caters to the need of individual differences in teacher training. Each trainee develops teaching skills at his own pace.
- It employs real teaching situations for developing skills.
- Microteaching gives instructors an opportunity to be analysed by a small group audience, and also to observe and comment on other people's performances.
- It is hardly a substitute for teaching practice, but it offers advantages such as close supervision, manageable objectives established according to individual trainee needs and progress, continuous feedback, an unprecedented opportunity for self-evaluation, immediate guidance in areas of demonstrated deficiency and the opportunity to repeat a lesson whenever desired.
- Through microteaching, teachers are able to pursue self-initiated, self-directed and self-observed growth.
- It is a very useful method for both pre-service and in-service teacher education.
- Microteaching offers the advantages of both controlled laboratory environment and realistic practical experience.
- A microteaching session is a chance to adopt new teaching and learning strategies.
- It is well suited to help teachers identify single concepts, and learn how to create learning modules to build longer lessons.
- Microteaching can also be used in research work in various situations related to teaching.

NOTES

3.2.6 Disadvantages of Microteaching

The limitations of microteaching are as follows:

- It is skill-oriented rather than content-oriented. The main emphasis in this technique is on learning teaching skills and content, which is an important part of teaching-learning, is given adequate attention.
- It is performed in artificially controlled conditions.
- The main emphasis of microteaching is on mastery of one teaching skill at a time, whereas actual teaching is a combination of many skills that operate simultaneously.
- It is a time-consuming technique since one trainee practises a skill in about 35 minutes.
- An effective microteaching technique requires tape records, video tapes and closed circuit cameras. Thus, it is costly for Indian schools.
- For successful implementation, microteaching requires competent and suitably trained teacher educators.
- Microteaching alone is not sufficient to attain perfection in teaching. It needs to be supplemented and integrated with other teaching techniques.
- It cannot be a substitute for real classroom lesson.

NOTES

CHECK YOUR PROGRESS

1. Define 'microteaching'.
2. Who introduced the concept of microteaching?
3. Name the components of a microteaching cycle.
4. Name any five skills of microteaching.
5. Give one advantage and one disadvantage of microteaching.

3.3 TEACHING MODEL

Development of models of teaching is one of the recent innovations in teaching. An important purpose of discussing models of teaching is to assist the teacher to have a wide range of approaches for creating a proper interactive environment for learning. An intelligent use of these approaches enables the teacher to adapt him to the learning needs of the students.

A number of educationists and psychologists have proposed the model-approach to teaching. Ned A. Flanders (1970) put his interaction analysis as a model of teaching and for this approach he categorised the statements of students and teachers into ten categories. Robert Glaser (1962) divided instructional material in his model into four components. These are instructional objectives.

The credit for transforming the prevailing teaching theories into different models of teaching goes to Bruce Joyce and Marsha Weil (1980).

In India, the first national project on models of teaching was planned, designed and executed during 1985-86.

Teaching models have been defined in a number of ways. Some of the important definitions of a teaching model are given here to have a wider perspective of this concept.

Definitions of Teaching Model

Allen and Ryan (1969): Modelling is an individual demonstrating particular pattern which the trainee learns through imitation.

Albert Bandura (1969): Modelling demonstrates that virtually all learning phenomena resulting from direct experiences can occur on a vicarious basis through observation of other person's behaviour and its consequences for them.

B. K. Passi, L. C. Singh and D. N. Sansanwal (1991): A model of teaching consists of guidelines for designing educational activities and environments. Model of teaching is a plan that can also be utilised to shape courses of studies, to design instructional material and to guide instruction.

Bruce R. Joyce and Marsha Weil (1972): Teaching models are just instructional designs. They describe the process of specifying and producing environmental situations which cause the student to interact in such a way that specific change occurs in the behaviour. Teaching model is a pattern or plan, which can be used to shape a curriculum or course to select instructional materials and to guide a teacher's actions.

N. K. Jangira and Ajit Singh (1983): A model of teaching is a set of inter-related components arranged in a sequence which provides guidelines to realise a specific goal. It helps in designing instructional activities and environmental facilities, carrying out of these activities and realization of the stipulated objectives.

Paul D. Eggen et al (1979): Models are prescriptive teaching strategies designed to accomplish particular instructional goals.

Paul D. Eggen and others (1979) explain the meaning of a model in these words, 'An engineer, in considering a project, first identifies the type of structure to be built, e.g., a building, a bridge or a road. Having done this, he selects an appropriate design or blueprint to follow in building that structure. The specifications of the blueprint determine the actions the builder takes and the kind of building that will result. The particular type of blueprint or model chosen depends on the type of structure to be built. In a similar manner a teacher considering the choice of a teaching model first identifies what is to be taught and then selects a model in accordance with that goal. The model chosen is specifically designed to achieve a particular set of objectives and will determine in large part of the actions of the teachers.'

Educators and psychologists have designed several types of teaching models which provide suitable guidelines to the teachers for modifying the behaviour of the learners. As a matter of fact some sort of models of teaching have been in existence since time immemorial. In simple language, a model of teaching may be defined as

NOTES

a blueprint designed in advance for providing necessary structure and direction to the teacher for realizing the stipulated objectives.

3.3.1 Nature of Teaching Models

NOTES

Some common identifiable characteristics of a good model, are given below:

- **Specification of learning outcome:** All models of teaching specify what the students should perform after completing an instructional sequence.
- **Specification of environment:** A teaching model specifies in definite terms the environmental conditions under which a student's response should be observed.
- **Specification of criterion of performance:** A model of teaching specifies the criterion of performance which is expected from the students.
- **Specification of operations:** A model of teaching specifies the mechanism that provides for the reaction of students and interaction with the environment.
- **Scientific procedure:** A model of teaching is based on a systematic procedure to modify the behaviour of the learner. It is not a haphazard combination of facts.

Functions

Teaching models:

- Help in guiding the teacher to select appropriate teaching techniques, strategies and methods for effective utilisation of the teaching situation and material for realizing the objective
- Help in bringing about desirable changes in the behaviour of the learners
- Help in finding out ways and means of creating favourable environmental situations for carrying out teaching process
- Help in achieving desirable teacher-pupil interaction during teaching
- Help in the construction of a curriculum or contents of a course
- Help in the proper selection of instructional material for teaching the prepared course or the curriculum
- Help in designing appropriate educational activities
- Assist producers of materials to create interesting and effective materials and learning sources
- Stimulate the development of new educational innovations
- Help in the formation of a theory of teaching
- Help to establish teaching and learning relationship empirically
- Are useful in developing social efficiency, personal abilities, cognitive abilities and behavioural aspects of the students

Effects of teaching by modelling

A. Bandura and R. H. Walters mention three kinds of effects in teaching by modelling. These are: (i) a modelling effect (ii) an inhibitory and disinhibitory effect and (iii) an eliciting effect.

- **Modelling effect:** A modelling effect can be seen when a teacher demonstrates to a student how to hold a pencil or write Capital A, and thus, shows a new behaviour. Here, a student learns new kinds of response pattern.
- **Inhibitory and disinhibitory effect:** An inhibitory or disinhibitory effect takes place when through modelling we let the student know that it is not possible to look at pictures of nudes, in an art book.
- **Eliciting effect:** The eliciting effect takes place when a teacher through modelling tries to teach students to rise when a lady enters the room, and thus, provides a cue eliciting a response neither new nor inhibited.

Modelling and other similar terms: Among those in common use are modelling, imitation, observational learning, identification, copying, vicarious learning, social facilitation, and role playing.

Robert Gagne feels that learning through imitation seems to be more appropriate for tasks which have little cognitive structure.

Neal E. Miller and John Dollard also plead for learning by imitation. There is no doubt that modelling plays an important role in the development of our personality. Imitation contributes immensely to the learning of values, beliefs, attitudes and sentiments.

It is because of this that great stress is laid on the selection of right type of teachers who in turn must be very careful in the selection of learning experiences in the class.

Three stages of modelling: Three stages in the development of a model are:

- Analysis of a particular skill
- Identification of the key elements in it
- Exposition of the elements in such a way as to exemplify satisfactorily the skills under consideration

3.3.2 Elements of a Teaching Model

A teaching model has six fundamental elements: (i) focus (ii) syntax (iii) principles of reactions (iv) the social system (v) the support system (vi) application context.

Focus: Focus is the central aspect of a teaching model. Objectives of teaching and aspects of the environment generally constitute the focus of the model.

Syntax: Syntax includes the sequence of steps involved in the organisation of the complete programme of teaching.

Principles of reactions: This element is concerned with the way a teacher should regard and respond to the activities of the students. These responses should be appropriate and selective.

NOTES

Social system: It is related to the description of the following: (i) interactive roles and relationships between the teacher and the students, (ii) the kinds of norms that are observed and student behaviour which is rewarded.

NOTES

Support system: The support system relates to the additional requirements other than the usual human skills or capacities of the teacher and the facilities usually available in the ordinary classroom. These requirements refer to special skills, special knowledge of the teachers and special audio-visual material like films, self-instructional material and visit to special places.

Application context: Several types of teaching models are available. Each model attempts to describe the feasibility of its use in varying contexts—goal achievements—cognitive, conative and effective.

Sources of models of teaching

Four important sources from which all the models of teaching have been derived are given below:

- **Social interaction sources:** The model of teaching of this category emphasises the importance of social relationship of the person and are based on the assumption that social relation is the vehicle of education.
- **Information processing sources:** The other source of model of teaching is the information processing capability of the learner which means the way in which people handle stimuli, organise data, sense problems and solve them. The model of this category emphasises the use of specific strategies within academic disciplines which lead to the development of creativity and general intellectual ability of learners.
- **Personal sources:** Personal and emotional life of the individual and their internal organisation as it affects relationship with this environment are the sources of this category of models.
- **Behaviour modification as a source:** The operant conditioning theory built by B. F. Skinner is the origin of this type of model which is purely a psychological model and is used in most of the teaching strategies developed in the last two decades.

Assumption

- Each model is based on the assumption that teaching is the creation of appropriate environment and various components of the environment are interdependent.
- Environment system consists of the content, skill, social relationships, instructional roles, activities and physical facilities. All these elements interact.
- Various combinations of the different elements of the environment create different types of environments, and elicit different outcomes.
- Models of teaching create environment.

Five-fold classification

Some educators classify the teaching models as under:

(i) *Historical teaching models*

- Socratic teaching model—Socrates
- Classical humanistic model— Brody
- Personal Development model—Carl Rogers

(ii) *Philosophical models of teaching*

- Impression model—John Locke
- Insight model—Plato
- Role model—Kant

(iii) *Psychological models of teaching*

- Basic teaching model—Robert Glaser
- Computer based teaching model—Lawrence Stolyrow and Davis
- Interaction model of teaching—Ned A. Flanders
- Teaching model of school learning—John Carroll

(iv) *Teaching model for teacher education.*

- Toba's model of teaching
- Turner's model of teaching
- Model of variation in teacher orientation
- Life-Long Teacher Education Programme (LLTEP) Model

(v) *Modern teaching models*

- Behaviour modification models
- Information processing models
- Personal models
- Social interaction models

3.3.3 Types of Modern Teaching Models

Bruce Joyce and Marsha Weil (1985) organise these models into the following four families on the basis of their chief emphasis—the way they approach educational goals and means.

Types (Families) of Models

Behaviour Modification Models	Information Processing Models	Personal Models	Social Interaction Models
-------------------------------------	-------------------------------------	-----------------	---------------------------------

(i) Behaviour Modification: Behaviour modification models stress on changing the external behaviour of the learners and describe them in terms of visible behaviour rather than underlying behaviour. Skinner is the chief exponent of this model. (Table 3.2).

NOTES

Table 3.2 Behavioural Modification Models

NOTES

Model		Chief Exponents	Goals or Missions for which most Applicable
1	Anxiety reduction	Rinn, Wolpe	Substitution of relaxation for anxiety in social situation
2	Assertive training	Wolpe, Lazarus, Salter	Direct, spontaneous expression of feelings in social situations.
3	Direct training	Lumsolaine	Pattern of behaviour, skills
4	Managing behaviour	B.F. Skinner	Social behaviour, skills
5	Programmed	B.F. Skinner	Facts, Concepts, skills
6	Relaxation	Rinn, Wolpe	Reduction of stress
7	Self-control	B.F. Skinner	Social behaviour, skills

(ii) Information Processing Model: Information processing models refer to the way people handle stimuli from the environment, organise data, sense problems, generate concepts and solution to problems and use verbal and non-verbal symbols. Models of this type are concerned with the intellectual growth rather than the emotional or social development (Table 3.3).

Table 3.3 Information Processing Models

Model		Chief Exponents	Goals or Missions for which Applicable
1.	Advanced organiser model	David Ausubel	Designed to increase efficiency of information processing capacities to absorb related body of knowledge
2.	Cognitive growth	Jean Piaget, Irving Sigel, Edmund Sullivan	Designed to increase general intellectual development especially logical reasoning, but can also be applied to social and moral development
3.	Concept attainment	Jeromer Bruner	Designed primarily to develop inductive, reasoning but also for concept development analysis
4.	Inductive thinking inquiry	Hilda Taba, Richard, Suchman	Designed primarily for development of inductive mental processes and academic reasoning
5.	Memory	Jerry Lucas	Designed to increase capacity of memorisation
6.	Scientific inquiry	Joseph J. Schwab	Designed to teach the research system of a discipline but also expected to affect other domains

(iii) Personal development models: Personal development models assist the individual in the development of selfhood. Frequently, they focus on the emotional life of an individual. (Table 3.4)

Table 3.4 Personal Models

	<i>Model</i>	<i>Chief Exponent</i>	<i>Goals or Mission for which Most Applicable</i>
1.	Awareness training	Fritz Perls, William Schulz	Designed to increase one's capacity for self-exploration and self-awareness.
2.	Classroom meeting (social problem solving)	William Glaser	Designed to develop self-understanding and responsibility to oneself and one's social group
3.	Conceptual systems	David Hunt	Designed to increase personal complexity and flexibility
4.	Non-directive teaching	Carl Rogers	Designed to lay emphasis on building the capacity for personal development in terms of self awareness, understanding, autonomy and self-concept
5.	Synetics	William Gordon	Designed for the personal development of creativity and creative problem-solving

NOTES

(iv) Social interaction models: Social interaction models stress the relationship of the individual to other persons and to society. (Table 3.5).

Table 3.5 Social Interaction Models

	<i>Model</i>	<i>Chief Exponents</i>	<i>Goals or Missions for which most Applicable</i>
1.	Group investigation	1. Herbert Thelem 2. John Dewey	Designed for the development of skills for participation in democratic social process through combined emphasis on interpersonal skills and academic inquiry skills
2.	Jurisprudential	1. Donald Olive 2. James P. Shaver	Designed primarily to teach the jurisprudential frame of reference as a way of thinking about and resolving social issues
3.	Laboratory method	National Training Laboratory (NTL)	Designed for the development of interpersonal and social group skills and through this personal awareness and flexibility
4.	Role playing	1. Famine Shafted 2. George shafted	Designed to induce students to inquire into personal and social values with their own behaviour and values becoming the source of inquiry
5.	Social inquiry	1. Byren massialas 2. Benjamin Cox	Designed for the development of social problem-solving primarily through academic inquiry and logical reasoning
6.	Social stimulation	Sarene Boocock	Deigned to help students experience various social processes and realities and to examine their own reactions to them

It may be noted that these models are not mutually exclusive. We find characteristics of one model apparent in some other models. Further, we find that information processing models, besides focussing on the development of intellectual skills and the acquisition of content, are also concerned with the development of

NOTES

social relations. Besides, some social interaction models emphasize on personal development of the individual.

Since education is meant for the all-round development of the personality of the child, no single model could be selected. We may be required to employ several models according to the requirement of the situation, that is if some information is to be given, models of the information family would be required; if creativity is to be developed in the child; the synectic model would be needed; if the objective is to eliminate anxiety and stress, the desensitization model would be needed; and if development of social skill is the objective, the group investigation model would be required.

The selection of a model can also be done in consideration of curriculum requirements. For example, a biology teacher may need the inductive model of Hilda Taba and the Concept Attainment Model of Brunner, while a social studies teacher who proposes to teach about values would need the role playing model of Fannie Shaftel and George Shaftel, which motivates to inquire into personal and social values. Some situation would require an application of a combination of models. In the social studies class, the teacher may have the inductive thinking model to help children master map skills and the group investigation model for discussing social issues.

Suggestions for the use of models in India: These models have been developed in foreign countries where the socio-economic conditions and cultural heritage are quite different from our country. So, while adopting/adapting these models we should take into consideration the following points:

- There is little experimental evidence to establish the superiority of one model over the other.
- We should not consider models of teaching as panacea for all the ailing from which our system of education suffers.
- Transplantation of foreign models without making necessary changes in accordance with the philosophy of life of our people will be harmful for the nation. Vigorous and continuous research is needed for their adoption in our country.
- Classes of activity to which the models can be related to should be identified. Models can be related to three important dimensions of the educational environment—the personal, the social and the intellectual. Balance should be maintained to develop the individual harmoniously.
- We should be very cautious in deciding the model in terms of skills and knowledge outcomes and social effects it will have on the society.

3.3.4 Glaser Model of Teaching or Basic Teaching Model

Basic teaching model was developed by Robert Glaser in 1962. It is termed as the basic model because it tries to explain the whole teaching process by dividing it into four basic components namely, (1) instructional objectives (2) entering behaviour (3) instructional procedures (4) performance assessment. All these four basic

components of the teaching process interact and influence each other as explained in the figure (Fig. 3.2)

- Instructional objectives indicate the stipulated goals that a student is expected to attain after the completion of a part of instruction. These are usually based on Bloom's Taxonomy of objectives.
- Entering behaviour implies the initial behaviour of the student before the beginning of instruction. The assessment of the entering behaviour is an important aspect of the instructional process.

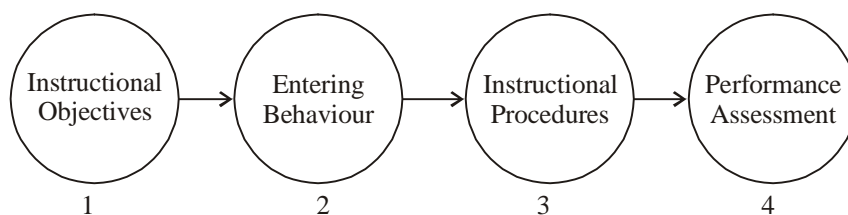

Fig. 3.2 Components of Teaching Process in Glaser's Basic Teaching Model

- Instructional procedures represent the teaching methods, strategies and student-teacher interaction patterns involved in teaching. Instructional procedures are guided by the nature of the instructional objectives and the entering behaviour.
- Performance assessment involves the extent to which the stipulated objectives have been fulfilled. It involves the use of suitable evaluation techniques like tests and observation. It serves as a feedback device for each of the steps and elements of the teaching process.

As a matter of fact, all these four basic components of the teaching process interact and influence each other. One sets the base for the other by providing a base or feedback for the successful operation of the teaching act.

Description of Glaser's model

Glaser's model may be described in terms of the fundamental elements as under:

- **Focus:** It attempts to pinpoint the processes and major activities comprising the entire teaching-learning process. It also brings into light the sequence to be followed in the instructional processes.
- **Syntax:** The flow of activities in this model is sequential. First of all the objectives to be followed are fixed in accordance with Bloom's Taxonomy. Then the potentiality of the learners in terms of their entry behaviour is assessed. Thereafter, in the light of the entry behaviour, instructional work is carried out for the achievement of stipulated objectives. Performance assessment is the last phase.
- **Principles of reactions:** Main principles of reaction are summarised below:
 - o *Principle of interdependence:* The student's responses are to be understood and dealt with in the light of the interaction and interdependence of the four stages, i.e., objectives, entry behaviour, instructional process and assessment.

NOTES

NOTES

- o *Principle of active involvement:* Its proper execution requires a lot of activity on the part of the teacher. At every stage the teacher is expected to develop proper understanding of the potential and difficulties of his students for achieving the objectives.
- o *Principle of follow up:* In case the results are not in accordance with the set objectives, gaps and deficiencies have to be found out and corrective measures taken.

Social system: The success of this model depends upon the ability and competency of the teacher in terms of various skills like formulation of objectives, use of proper strategies and techniques of evaluation.

Support system: The model for its success needs additional support in terms of (i) availability of adequate pre-service and in-service facilities to teachers to acquire needed competencies and skills for the use of the model (ii) availability of desirable teaching-learning environment and situations for the use of suitable teaching strategies (iii) availability of appropriate evaluation devices for the assessment of entry and terminal behaviour of the learners.

Applicability of the model: Being quite systematic and structured, this model is applicable to almost all learning-teaching situations.

Glaser's model indicates that teaching includes a wide range of decisions and practices and much of which requires little or no personal contact between the teacher and student. It implies a greater emphasis on the competency of the teacher than on his personality.

3.3.5 Classroom Meeting Model

Classroom meeting model was developed by William Glasser in 1965. It is based on the assumption that the success or failure of an individual depends more on the social factors rather than on his personal limitations. Through classroom meeting, Glasser wants to see the whole school fully disciplined. All classroom meetings should result into model behaviour of the individuals. Each classroom meeting should be positive in nature and based on two basic needs namely, need for love and respect.

Description of the different elements of the model

- **Focus:** The main aim of the model is to develop moral values and social norms among the students by providing appropriate social environment.

Syntax: The model involves the following six phases:

Phase 1: It is related to the creation and maintenance of a suitable climate of involvement and establishing adequate rapport with the students.

Phase 2: It is concerned with the exposition of the problem for discussion.

Phase 3: It involves encouraging the students to make value judgements about their behaviour.

Phase 4: It relates to the identification of alternative courses, both by students and teachers, to find out the solution of the problem.

Phase 5: In this phase, the teacher impresses upon the student to choose a selected path and pushes them for behaviour commitment.

Phase 6: In this phase, follow-up is provided and the students carry out the decisions arrived at.

- **Principles of reaction:** The main principles are as under:
 - o Principle of active involvement which means that the teacher should show affection, sympathy, understanding and warmth to his students.
 - o Principle of value judgement which implies that the students are made to assess their own behaviour, to accept their weak points in their interpersonal and social behaviour and find solutions for them.
- **Social system:** This model is moderately structured. The students initiate the problem and cooperatively discuss and find out its solutions. The leadership remains with the teacher but the latter remains non-judgmental. The moral authority remains with the students.
- **Support system:** The teacher must provide proper environment for proper group discussion. He must create a climate of openness.

Applicability of the model: The model has been developed to prepare socially desirable individuals. It attempts to nurture openness and responsibility in students. It leads to the individual to make attempts to understand his own behaviour, seek value judgement and modify his behaviour for his self-good and the good of the society.

3.3.6 Uses and Limitations of Teaching Models

Following are the reasons why teaching models are used and their benefits.

- Teaching models cater to a wide variety of students.
- It results into diverse results, different levels of intricacy.
- In teaching models, there is a wide range of methodologies.
- Teaching models present facts in an undeviating and rational manner.
- It motivates the students to think rationally and question as much as possible.
- It is very useful for large groups.

Teacher benefits

- Teaching models enhance the quality of teaching and training.
- It provides an efficient approach towards designing for teaching.
- It helps the teacher to be in contact with the students and to be aware of their learning needs.
- It also helps the teacher to measure the outcomes of the teaching process.
- It provides for a substitute path for representing content/skills.
- It helps in the advancement of learning that results in positive consequences.
- It also helps the student to participate actively in the class.

NOTES

NOTES

Student benefits

- Teaching models escalates the learning skill and also the skill of retention.
- Students tend to learn quickly with the use of teaching models.
- It also helps in diverse kinds of learning.
- It also helps in boosting the academic self-esteem of the student.
- It recognizes skills and the abilities of the students.
- Students are made aware of the teaching plans and the changes made in the plans.

Limitations of teaching models

- Only very intelligent or resourceful teachers can take advantage of these teaching models, a moderate teacher can hardly make use of it.
- All the students may not be able to participate in the teaching-learning process.
- Shy students hesitate to speak in class and hence lag behind.
- Some students may not catch up with the level of the teacher.

CHECK YOUR PROGRESS

6. What is the purpose of discussing models of teaching?
7. List the nature of teaching models.
8. Name the fundamental elements of a teaching model.
9. Who is the chief exponent of the behaviour modification model?
10. List the limitations of teaching models.

3.4 INFORMATION PROCESSING MODELS

Cognitive psychologists promote the use of information-processing models to describe and explain the human mental process. Educators and trainers regularly use this model to guide their teaching methodologies. The model likens the human thought process to the working of a computer. It considers information to flow through various internal structures present in a learner. Similar to a computer, a human mind absorbs information, organizes and stores it to be retrieved and used at a later period. A better understanding of how information flows, is processed, stored and retrieved through the information-processing model, and allows learners to understand more efficiently and systematically.

In a computer, information is fed through input devices such as a keyboard or scanner. It is called the sensory register in the human mind, composed of the sensory organs such as the eyes and ears through which we receive information. In a computer, the information received is processed in the central processing unit, which corresponds to the working memory or short-term memory. This information is stored

in the hard disk and displayed on the screen or as a printout. Similarly, the human mind stores information for further use or it is transferred to the long-term memory, which is the human hard disk, or is discarded. The product of this information is exhibited through behaviour or actions. Human beings can extract the information from the long-term memory, which can be thought of as our consciousness. In certain cases, automatized skills are transferred directly from the long-term memory to the response generator, such as the skills used in operating a machine by an expert without a second thought.

NOTES

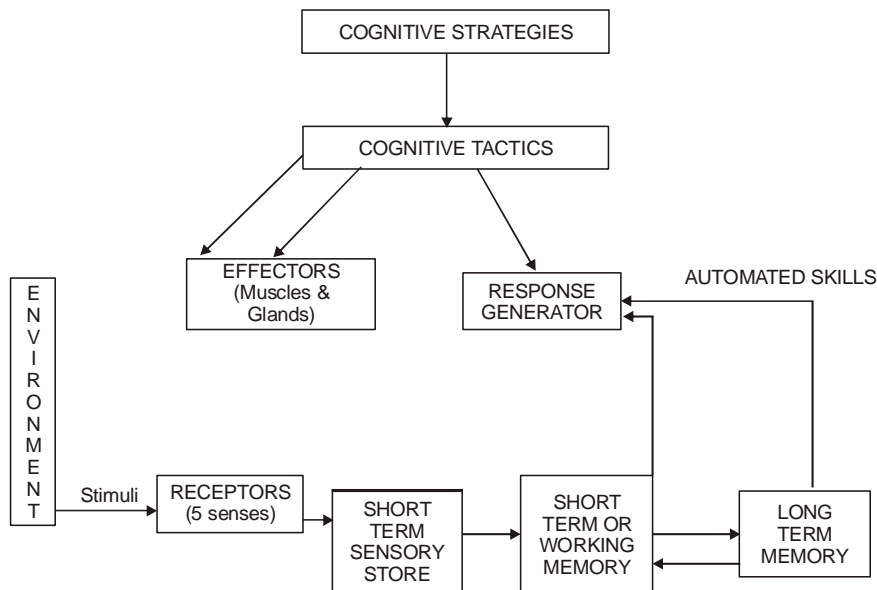

Fig. 3.3 Information Processing Model

According to American educational psychologist Robert Mills Gagné (1993), when we try to comprehend memories and retrieve information, stimulation from the environment activates the receptors. The entire information from the surrounding is replayed to the short-term sensory store for two functions. First, it filters out insignificant information and focuses on the crucial one through selective perception. However, the importance and relevance of an incident varies from person-to-person. Hence, people may remember different things of the same incident, after reading the same book, watching the same movie or listening to the same lecture. Second, it makes sense of the various patterns of stimulation impinging on it. For example, a series of sounds of fluctuating frequencies and amplitudes is heard as speech; different colours and intensities of light entering the eye are decoded by the short-term sensory store and we see objects.

A combination of a number of cognitive tactics, hence, forms cognitive strategies. These strategies direct human behaviours while thinking, memorizing and attending, and also to select which of the cognitive strategies and tactics is to be implemented in a particular situation. The necessity to choose strategies is termed as the need to act meta-cognitively to control your learning behaviour. A meta-cognitive learner will always self-monitor one's learning strategies. After selecting a cognitive tactic to put in use, the learner has to stand outside to monitor while evaluating

whether the strategy was correct. If not found efficient, the learner has to modify or even change the strategy.

Basic assumptions

NOTES

The information-processing model is based on a number of assumptions; these are:

- Information processing in humans resembles that of computers
- The environment provides information which is processed by a series of processing systems such as attention, perception, and short-term memory
- These processing systems transform the information systematically
- The aim of research is to specify the processes and structures that underlie cognitive performance

Information processing and attention

It has been observed that humans, when they selectively attend to an activity tend to ignore other stimulations, although they can be distracted by other sounds, such as calling of name or sound of a door bell. This tendency of selective attention has been an intriguing query for psychologists as they question how many things human beings can attend at the same time (attentional capacity).

One way of dealing with the question would be to consider humans as an information processor who has the capacity to process only a limited amount of information at a given period without being overloaded.

Information-processing system



Fig. 3.4 Information on Processing System

The information processing system, as shown above, indicates the flow of information from one stage to the next.

- Input processes are concerned with the analysis of the stimuli
- Storage processes cover everything that happens to stimuli internally in the brain and can include coding and manipulation of the stimuli
- Output processes are responsible for preparing an appropriate response to a stimulus.

Types of information processing

Information processing can be sequential or parallel, either of which may be centralized or decentralized (distributed). The parallel distributed processing approach, propagated in the mid-1980s, became popular as connectionism. In the early 1950s, Friedrich Hayek had advocated that the brain takes spontaneous orders through decentralized networks of simple units (neurons).

The connectionist network is made up of different nodes, and it works by a 'priming effect', and this happens when a 'prime node activates a connected node'

(Sternberg & Sternberg, 2012). But ‘unlike in semantic networks, it is not a single node that has a specific meaning, but rather the knowledge is represented in a combination of differently activated nodes’ (Goldstein, as cited in Sternberg, 2012).

3.4.1 Models and Theories

There are several proposed models/theories that describe the way in which we process information.

Sternberg’s Triarchic Theory of Intelligence

Sternberg’s intelligence theory includes three components—creative, analytical, and practical abilities (Sternberg & Sternberg, 2012). Creativity is the talent of coming up with original ideas, and analytical ability allows a person to evaluate the positives and negatives and whether the idea is a good one or not. Practical abilities are used to implement the ideas and persuade others of their value (Sternberg & Sternberg, 2012).

In the middle of Sternberg's theory is cognition and with that is information processing. According to Sternberg, information processing consist of three different parts—metacomponents, performance components, and knowledge-acquisition components (Sternberg & Sternberg, 2012). These processes move from higher-order executive functions to the lower-order. Metacomponents are used for planning and evaluating problems, while performance components follow the orders of the metacomponents, and the knowledge-acquisition component learns how to solve the problems (Sternberg & Sternberg, 2012). A practical implication of this theory would be like working on an art project. First the idea takes shape, then the concept is drawn mentally or is planned, and then a sketch is done. Through this entire process, the artist will monitor the work in progress. These steps come under the metacomponent processing, and the performance component would be the actual painting. The knowledge-acquisition portion would be learning how to draw what you want to draw.

Working memory

Information processing can be defined as the sciences concerned with gathering, manipulating, storing, retrieving, and classifying recorded information. It suggests that for information to be firmly implanted in memory, it must pass through three stages of mental processing; sensory memory, short-term memory, and long-term memory.

The working memory model is one such example. This includes the central executive, phonologic loop, episodic buffer, visuospatial sketchpad, verbal information, long-term memory, and visual information (Sternberg & Sternberg, 2012). The central executive is the one to decide what requires attention and how to respond. It has three sub-sections—phonological storage, sub-vocal rehearsal, and phonological loop. These sections work together to understand words, put the information into memory, and then hold the memory. The result is verbal information storage.

Visuospatial sketchpad is the next sub-section which stores visual images. The storage capacity is brief but leads to the understanding of visual stimuli. Finally,

NOTES

NOTES

there is an episodic buffer. This section collects information and puts it in long-term memory. It also takes information from the phonological loop and visuospatial sketchpad, combining them with long-term memory to make a unitary episodic representation (Sternberg & Sternberg, 2012). For these to work, the sensory register takes in via the five senses: visual, auditory, tactile, olfactory, and taste. These are present since birth and are able to handle simultaneous processing (e.g., food—taste it, smell it, see it). The benefits of learning become visible once there is a developed process of pattern recognition.

In general, learning benefits occur when there is a developed process of pattern recognition. The sensory register has an expanded capacity and its behavioural response is short (1–3 seconds). In this model, sensory store and short-term memory or working memory has limited capacity. Sensory store holds limited amounts of information for very limited time duration (Sternberg & Sternberg, 2012).

Short-term memory holds information for slightly longer period, but still has limited capacity. According to Linden (2007), ‘The capacity of short-term memory (STM) had initially been estimated at seven plus or minus two items’ (Miller 1956), which fits the observation from neuropsychological testing that the average digit span of healthy adults is about seven (Cowan and others 2005). However, these number of items can only be retained if they are formed into groups, using perceptual or conceptual associations between individual stimuli. Its duration is of 5–20 seconds before it is out of the subject's mind. This can be experienced when a new name is introduced to us. Here, images and information based on reasoning are stored but is forgotten if not repeated. Long-term memory, however, has unlimited capacity (Sternberg & Sternberg, 2012) with indefinite duration. At times it becomes inaccessible as it stores a lot of information till that particular time. This is when people say they forget or partially remembers in information.

CHECK YOUR PROGRESS

11. What is an information processing model?
12. What is the basic concept of information processing model?
13. Mention at least two basic assumptions of the model.
14. According to Sternberg, what are the three parts of information processing?

3.5 SIMULATED TEACHING

Experiential learning allows students to apply and test what they learn in their textbooks and often helps to increase students’ understanding of the subtleties of theories or concepts. It draws students who can be alienated by traditional teaching approaches. In role-play situation, students need to make decisions and often have to convince others to work with them. Simulations also provide students with the opportunity to develop their communication, negotiation and critical thinking skills and in many cases, improve teamwork skills. Simulations are a useful teaching strategy

for illustrating a complex and changing situation. Simulations are (necessarily) less complex than the situations they represent.

A simulation is a form of experiential learning. Simulations are instructional scenarios where the learner is placed in a situation defined by the teacher. They represent a reality within which students interact. The teacher controls the parameters of this situation and uses it to achieve the desired instructional results. Simulations are in a way lab experiments where students themselves are the test subjects. They experience the reality of the scenario and gather meaning from it. It is a strategy that fits well with the principles of constructivism.

NOTES

Definitions of Simulation

Some popular definitions of simulation are as follows:

- Simulation is a replica of a real world situation worth learning. An educational simulation permits a person to become a working member of the system, to set goals, to develop policies, to analyse information and make decisions (Klietsch, 1973).
- Simulation provides a simplified version of reality: an approximation of reality (Dhand, 1973).
- Simulation is a means of allowing student to live vicariously. It enables the teacher to manipulate various courses of action and their consequences (Broadbelt, 1969).

Assumptions of Simulated Teaching

Some of the basic assumptions of simulated teaching are as follows:

- *Teacher behaviour is modifiable:* The first assumption is that with the help of feedback devices, a teacher's behaviour can be modified and developed.
- *Patterns of teacher behaviour are essential:* There are certain patterns of teacher behaviour, which are essential in effective teaching. These patterns may be described and practised like any other skill.
- *Teacher behaviour has taxonomy:* According to Karl Openshaw and others, the taxonomy of teacher behaviour is developed by the use of simulated technique as:
 - o Source dimension
 - o Direction dimension
 - o Function dimension
 - o Sign dimension
- *Social skills are developed:* Another assumption is that social skills are developed by practice and imitation in a group. The members of the group have an opportunity to practise controlling and improving their own behaviour for teaching purposes.
- *Use of feedback:* The feedback mechanism can be used to modify the social communication skills of student-teachers.

NOTES

3.5.1 Objectives of Simulated Teaching

According to Flanders, simulated teaching has the following objectives:

- To ask open or closed questions at appropriate time
- To ask a question which lifts the current level of abstraction, or a question that lowers it
- To ask questions from areas, concepts and logical connections of those ideas that have been expressed by students previously
- To summarize all that has been previously said by the students
- To make appropriate use of ideas expressed previously by students
- To make constructive use of positive and negative feelings of students
- To provide reasons for praising or blaming
- To predict the consequences which follow alternative actions
- To assist students to compare the consequences of alternative actions through speculation before discussions are arrived at
- To guide constructive discussions
- To clarify the first steps needed to start work in ways that are in accordance with the interests and abilities of students
- To organize student's ideas in terms of teaching objectives
- To demonstrate and explain the rules of logic in classroom discourse
- To assist students to maintain consistency in the meaning of words and distinguish matters of facts, opinions and values

3.5.2 Educational Uses of Simulation

Simulations can typically be adapted internally to address the specific circumstances of students and the class environment. They can also be offered as a replacement for other teaching strategies, thus themselves being an adaptation. Vandana Mehra, in her book, *Education Technology*, has explained the uses of simulation in the following lines:

- Simulation establishes a setting where theory and practice can be combined.
- Simulation provides funny, interesting and meaningful learning experiences.
- A well-designed simulation can achieve positive transfer of learning.
- Simulation helps participants develop their initiative powers and creative thought.
- Simulation helps to foster content related to cognitive outcomes, non-cognitive skills (such as decision-making, communication and interpersonal skills) and desirable attitudinal traits (such as willingness to listen to other people's point of view) or appreciate that most problems can be viewed in a number of different ways.

- Simulation motivates participants to commit themselves whole heartedly to the work of the exercise.
- Simulations that are multidisciplinary in nature help participants to integrate concepts from related areas into a cohesive and balanced picture.
- Simulations help in reinforcing facts and principles after they have been taught.
- Especially in sciences, simulations help to develop laboratory skills in situations where conventional experiment is either extremely difficult or impossible.

NOTES

3.5.3 Types of Simulation

Norman has identified the following types of simulations:

- **Identity simulation:** In this simulation, the actual system is used as a model.
- **Replication simulation:** In this simulation, an operational model of the system is used in its usual environment.
- **Laboratory simulation:** In this type of simulation, replication is employed in the laboratory, with features of the real system represented.
- **Computer simulation:** This type of simulation is an abstract representation of the real system with the use of a computer.
- **Analytical simulation:** This type of simulation uses mathematical modes and attempts to get solution by analytical means.

3.5.4 Procedure of Simulated Teaching

Flanders has recommended six steps for using simulated teaching exercise. They are as follows:

- **Assignments:** First of all, a small group of student-teachers is selected. Each student-teacher in the group is assigned a number or letter. A system is built to rotate the role so that each individual gets a chance to be an actor, or an observer.
- **Selection and discussion of the skills:** In this step, the group decides and discusses the skill which is to be practised and lists down the topics of conversation that fits the skill. Each actor in the group can select a topic from this list that makes him comfortable in this role.
- **Deciding considerations:** In the third step, a sequence of activities is determined. Here, the following are decided:
 - o Who starts the conversation
 - o Who will intervene
 - o Who will start the interaction
 - o When will it be stopped
- **Deciding the procedure of evaluation:** The kind of data the observer needs to record and the method to be used to record the data is decided.
- **Conducting practice session:** Here, the first practice session is conducted and the actor gets feedback for his performance. The procedure of the second

NOTES

session is changed, if it is required to improve the training procedure. When each person has had the opportunity to be an actor and the practice session starts working properly, the task difficulty should be increased by restricting the actor's role.

- **To appraise and redesign the procedure:** One should be prepared to change the procedure and topic and then move on to the next skill, if needed.

3.5.5 Teacher Training and Simulated Teaching

Simulated teaching is one of the techniques used in India and other countries for the modification of teacher behaviour. Here, attempts are made to create artificial teaching–learning situations within the environment of the training institute and the student-teachers are required to play the role of teachers, students and supervisor. The main steps in this technique are as follows:

- (a) **Orientation:** First of all, student-teachers should be introduced to the concept and background of simulated teaching. Some important aspects of simulated teaching should be explained to student-teachers, which include:
 - Concept of simulated teaching
 - Importance and rationale of using simulated teaching for their training
 - The steps of procedure followed in its use
 - Necessary requirements and setting for adopting simulated teaching
 - Selection of the theme for teaching
- (b) **Giving demonstration lesson:** The teacher educator should try to give a demonstration of good teaching for practice of the skill selected. It will help student-teachers to understand the methodology to be employed during the practice of skill.
- (c) **Assignment of roles:** Every student-teacher in the group is going to play three different roles—teacher, student and observer. Therefore, prior judgment is required for deciding the order in which student-teachers will play their respective roles. However, it is to be remembered that irrespective of the order, everyone has to play all the three roles at one time or the other in the overall process of simulation.
- (d) **Selection of skill for practice:** After assigning roles, each trainee is now helped in the selection of suitable topics of his interest, in view of the skill to be practised. First of all, one topic is selected for practice, then it is decided which should be the other topic so that the other student-teachers may also go for practice in accordance with their assigned roles.
- (e) **Preparation of work schedule:** Here, the whole plan of the process is decided. The anticipated classroom interaction is planned, with respect to the role of trainees. The entire work schedule is to be prepared before starting the actual process.
- (f) **Determination of observation technique:** The procedure and technique of observation is decided and planned in advance. It also includes which type of data is to be collected and how this data is to be interpreted. The decision

regarding the use of these observations in providing feedback to the teacher actors is taken in advance.

- (g) **Organization of first practice session:** The first practice session is organized after all the above mentioned preparations are done. The student-teachers are asked to deliver lessons one by one to their peers who are playing the role of students. All good and weak points of teaching, concerning classroom interaction, teacher's behaviour, content taught, skills practiced and methodology used are being noted down by student-teachers who are playing the role of observers.
- (h) **Follow-up during subsequent practice session:** After desirable modifications in the first session, subsequent sessions are conducted till the goals of practicing teaching skills are not achieved. In this changed procedure, the roles of student-teachers are also changed so that all of them are provided with the opportunity to practise teaching skills.

NOTES

3.5.6 Precautions in Simulated Teaching

Following precautions should be taken in simulated teaching:

- Teachers must be completely familiar with the technique in order to maximize student learning.
- Teachers should ensure that students understand the procedures before beginning the process.
- Teachers must divide students into groups in a proper manner so as to have a positive impact of learning.
- Teachers should be knowledgeable and facilitators of the process.
- Sufficient time must be allocated to provide opportunity to student-teachers to play different roles.
- For practice, student-teacher should prepare micro-lesson plans.
- If possible, students should be made aware of specific outcomes expected of them.
- At the end of the process, a discussion should be followed so that student-teachers may bring desirable changes in their behaviour.

3.5.7 Advantages of Simulated Teaching

Simulated teaching has the following advantages:

- Can be used to analyse complex real classroom situations which may help in solving serious teaching problems. Good simplifications provide students with a better insight into reality, than by examining all components of a complex situation.
- The process of simulation is focused on the individual, but makes use of a learning group to support decisions and provide reflection. This emphasizes inquiry, skill development, collaboration and reflection.

NOTES

- The structure of a devised simulation incorporates feedback and advice, specifically through devices such as a thinking space plus the opportunity to repeat a lesson and explore alternative decisions. Usually, this is not feasible in traditional modes of classroom experience for pre-service teachers.
- Simulation creates an interactive educational setting which offers the possibility to effect changes in relation to the learning experience in a more efficient way, than is normally possible with other didactic methods.
- Student-teacher gets an opportunity to play three different roles of: student, teacher and observer.
- Simulations also provide students with the opportunity to develop their communication, critical thinking skills, and decision-making and teamwork skills.
- Simulations increases the students' interest, motivation and efforts for learning a subject or phenomenon.
- Students get an opportunity to imbibe useful qualities for social participation and cooperation by giving due regard to others' feeling and viewpoints.
- The technique is helpful in acquiring various teaching skills.
- Simulated teaching helps students in understanding behavioural problems of the classroom and also assists in developing an insight to encounter them.
- Simulated teaching helps in acquiring classroom manners.
- One of the major advantages of simulated teaching is that it establishes a link between theory and practice.
- This technique helps in developing the ability to ask the questions in student-teachers relationship.
- A simulation stimulates active engagement of students. They actually participate and not just read and analyse. They make decisions and see the results of their decisions in the responses from other students, and the outcome of the simulation.
- With simulations, students can explore the impact of multiple decisions at the same time. Simulations also allow students to validate their common sense, relative to a particular situation.
- Simulations provide varieties in pedagogy. They also provide rapid feedback on student decision-making, which is so critical for their learning.
- Simulation is very useful for gifted and slow learners.
- It develops confidence in student-teachers, which help them to confront tough situation.

3.5.8 Disadvantages of Simulated Teaching

Simulated teaching has the following limitations:

- Students may not understand problems of the classroom with needed effectiveness.

- This technique requires expertise on part of the teachers and very few teachers are ready to take extra burden.
- This technique creates an artificial situation which is away from reality.
- If audio-visual aids are to be used in classroom situation, special facilities and expensive equipment are essential.
- It is a time-consuming process in terms of planning, preparation, organization, presentation and evaluation.
- In this technique, student-teachers play the role of students. As they are quite mature, we cannot expect them to play the role of children.
- This technique cannot be used for the curricula of all subjects.

NOTES

CHECK YOUR PROGRESS

15. Define 'simulation'.
16. Give any two assumptions of simulation.
17. What happens in laboratory simulation?
18. Mention any one advantage of simulation.

3.6 SUMMARY

- A trainee teacher is bewildered by the complexity of teaching a large class of students and finds it very difficult to learn all aspects of teaching at the same time. It is easier for him to practice and learn one skill of teaching at a time. This problem was resolved by a process of training teachers in practical teaching. It came to be known as microteaching.
- Microteaching is an experiment in the field of teacher education, which has been incorporated in the practice teaching schedule.
- The six steps generally involved in microteaching cycle are: (i) plan, (ii) teach, (iii) feedback, (iv) re-plan, (v) re-teach and (vi) re-feedback.
- After several years of research and experimentation in microteaching, NCERT concluded that microteaching can be practised effectively in India without using any hardware, since symbolic and live modelling and verbal feedback have been found to be quite effective.
- In a classroom, interaction between students and teacher is a must otherwise the classroom environment will become monotonous.
- Reinforcement denotes an event that influences the probability of a response to a stimulus being produced under similar conditions. It belongs to the psychology of learning. It is of two types: positive and negative.
- The process of asking questions during classroom teaching is considered as the most important part of teaching. It makes students more thoughtful and they become able to understand the depth of the subject.

NOTES

- One major advantage of microteaching is the provision of immediate feedback to bring improvement in teacher's behaviour.
- The main emphasis of microteaching is on mastery of one teaching skill at a time, whereas actual teaching is combination of many skills that operate simultaneously.
- Development of models of teaching is one of the recent innovations in teaching. An important purpose of discussing models of teaching is to assist the teacher to have a wide range of approaches for creating a proper interactive environment for learning.
- A teaching model specifies in definite terms the environmental conditions under which a student's response should be observed.
- Teaching models help in guiding the teacher to select appropriate teaching techniques, strategies and methods for effective utilisation of the teaching situation and material for realizing the objective.
- A teaching model has six fundamental elements: (i) focus (ii) syntax (iii) principles of reactions (iv) the social system (v) the support system (vi) application context.
- Information processing models refer to the way people handle stimuli from the environment, organise data, sense problems, generate concepts and solution to problems and use verbal and non-verbal symbols.
- Basic teaching model was developed by Robert Glaser in 1962. It is termed as the basic model because it tries to explain the whole teaching process by dividing it into four basic components namely, (1) instructional objectives (2) entering behaviour (3) instructional procedures (4) performance assessment.
- Glaser's model indicates that teaching includes a wide range of decisions and practices and much of which requires little or no personal contact between the teacher and student.
- Classroom meeting model was developed by William Glasser in 1965. It is based on the assumption that the success or failure of an individual depends more on the social factors rather than on his personal limitations.
- Cognitive psychologists promote the use of information-processing models to describe and explain the human mental process. Educators and trainers regularly use this model to guide their teaching methodologies.
- Information processing can be sequential or parallel, either of which may be centralized or decentralized (distributed). The parallel distributed processing approach, propagated in the mid-1980s, became popular as connectionism.
- Experiential learning allows students to apply and test what they learn in their textbooks and often helps to increase students' understanding of the subtleties of theories or concepts.
- Simulations also provide students with the opportunity to develop their communication, negotiation and critical thinking skills and in many cases, improve teamwork skills.

- Simulations that are multidisciplinary in nature help participants to integrate concepts from related areas into a cohesive and balanced picture.
- Simulations provide varieties in pedagogy. They also provide rapid feedback on student decision-making, which is so critical for their learning.

NOTES

3.7 KEY TERMS

- **Microteaching:** Microteaching is a teacher education technique, which allows teachers to apply the clearly defined teaching skills in carefully prepared lessons.
- **Reinforcement:** Reinforcement is an event that influences the probability of a response to a stimulus being produced under similar conditions.
- **Behaviour modification model:** Behaviour modification models stress on changing the external behaviour of the learners and describe them in terms of visible behaviour rather than underlying behaviour.
- **Information processing model:** Information processing models refer to the way people handle stimuli from the environment, organise data, sense problems, generate concepts and solution to problems and use verbal and non-verbal symbols.
- **Simulation:** A simulation is a form of experiential learning. Simulations are instructional scenarios where the learner is placed in a situation defined by the teacher.

3.8 ANSWERS TO ‘CHECK YOUR PROGRESS’

1. ‘Microteaching’ is an education technique that allows teachers to apply clearly defined teaching skills in carefully prepared lessons, in a planned series of encounters with a small group of real students.
2. Dwight Allen introduced the concept of microteaching.
3. The components of microteaching are: plan, teach, feedback, re-plan, re-teach and re-feedback.
4. Five skills of microteaching are:
 - Skill of questioning
 - Skill of explaining
 - Skill of stimulus reinforcement
 - Skill of illustrating with examples
 - Skill of classroom management
5. A major advantage of microteaching is the provision of immediate feedback to bring improvement in a teacher’s behaviour. A prime disadvantage of microteaching is that it is skill-oriented rather than content-oriented. The main emphasis in this technique is on learning teaching skills and no adequate attention is given to content.

NOTES

6. Development of models of teaching is one of the recent innovations in teaching. An important purpose of discussing models of teaching is to assist the teacher to have a wide range of approaches for creating a proper interactive environment for learning.
7. The nature of teaching models are as follows:
 - **Specification of learning outcome:** All models of teaching specify what the students should perform after completing an instructional sequence.
 - **Specification of environment:** A teaching model specifies in definite terms the environmental conditions under which a student's response should be observed.
8. A teaching model has six fundamental elements: (i) focus (ii) syntax (iii) principles of reactions (iv) the social system (v) the support system (vi) application context.
9. B. F. Skinner is the chief exponent of the behaviour modification models.
10. The limitations of teaching models are:
 - Only very intelligent or resourceful teachers can take advantage of these teaching models, a moderate teacher can hardly make use of it
 - All the students may not be able to participate in the teaching-learning process
 - Shy students hesitate to speak in class and hence lag behind
 - Some students may not catch up with the level of the teacher
11. Information-processing models refer to the way people handle stimuli from the environment, organise data, sense problems, generate concepts and solution to problems and use verbal and nonverbal symbols.
12. The information-processing model likens the human thought process to the working of a computer. It considers information to flow through various internal structures present in a learner.
13. The information-processing model is based on a number of assumptions; two of them are:
 - Information processing in humans resembles that in computers
 - The environment provides information which is processed by a series of processing systems such as attention, perception, and short-term memory.
14. According to Sternberg, information processing consist of three different parts—metacomponents, performance components, and knowledge-acquisition components.
15. 'Simulation' is a means of allowing students to live vicariously. It enables the teacher to manipulate various courses of action and their consequences.
16. Two assumptions of simulation are as follows:
 - (i) *Teacher behaviour can be modified:* The first assumption is that with the help of feedback devices, a teacher's behaviour can be modified and developed.

(ii) *Patterns of teacher behaviour are essential:* There are certain patterns of teacher behaviour which are essential in effective teaching. These patterns may be described and practised like any other skill.

17. In laboratory type of simulation, replication is employed in the laboratory with features of the represented real system.
18. One advantage of 'simulated teaching' is that it establishes a link between theory and practice.

NOTES

3.9 QUESTIONS AND EXERCISES

Short-Answer Questions

1. What are the characteristics of microteaching?
2. State the objectives of introducing microteaching in colleges.
3. List the phases of microteaching.
4. What are the steps involved in microteaching cycle?
5. Differentiate between microteaching and traditional teaching.
6. What is the skill of reinforcement?
7. What are the major limitations of microteaching?
8. Enumerate the functions of teaching models.
9. What are the types of modern teaching models?
10. Write a note on the Glaser's model of teaching or the basic teaching model.
11. List the uses of teaching models.
12. What is information-processing system?
13. What are the educational values of simulation?
14. What are the components of simulation?
15. What are the types of simulation?

Long-Answer Questions

1. How can you modify teaching behaviour with help of 'microteaching'? Discuss in detail.
2. What are 'teaching skills'? Discuss any three in detail.
3. Define 'microteaching' and its steps. Also mention the advantages and limitations of microteaching.
4. Assess the concept, types, uses and limitations of models of teaching.
5. Discuss the various theories of information-processing models.
6. What is 'simulation'? Explain the types, advantages and disadvantages of simulated teaching.

3.10 FURTHER READING

NOTES

- Aggarwal, J. C. 2009. *Essentials of Educational Technology*. New Delhi: Vikas Publishing House.
- Kochhar, S. K. 1985. *Methods and Techniques of Teaching*. New Delhi: Sterling Publishers.
- Mangal, S. K. 2001. *Foundation of Educational Technology*. Ludhiana: Tendon Publications.
- Sampath, K., A. Panneerselvam, S. Santhanam. 2007. *Introduction to Educational Technology*. New Delhi: Sterling Publishers.
- Shankala, D.P. 2006. *Educational Technology*. New Delhi: Adhyayan Publishers and Distributors.
- Sharma, K. K. 2007. *Educational Technology*. Delhi: Mahaveer & Sons Publishers and Distributors.
- Sharma, R. A. 2002. *Technology of Teaching*. Meerut: International Publishing House.

UNIT 4 TEACHING AIDS

Structure

- 4.0 Introduction
- 4.1 Unit Objectives
- 4.2 Teaching Aids for Teaching
 - 4.2.1 Psychology of Using Teaching Aids/Audio-visual Aids
- 4.3 Types of Teaching Aids
 - 4.3.1 Non-projected Aids
 - 4.3.2 Projected Aids
 - 4.3.3 Audio-visual Aids
 - 4.3.4 Computer as a Teaching Aid
- 4.4 Summary
- 4.5 Key Terms
- 4.6 Answers to 'Check Your Progress'
- 4.7 Questions and Exercises
- 4.8 Further Reading

NOTES

4.0 INTRODUCTION

As a discipline, educational technology extends beyond the total of its components. In the present context, educational technology connotes a field of study including instructional design, audio-visual media, teaching–learning process, teaching strategies, training strategies and assessment strategies. Educational technology is far more than just technology; its bases are psychology, social anthropology and sociology. Early developments in this field defined the use of technology in education as the involvement of audio-visual equipment, i.e., hardware in educational processes. The use of hardware in teaching–learning results increased effectiveness of the education process. This progression in the field changed the definition of technology in education, i.e., methods and techniques of the teaching–learning process.

This signifies the software section of educational technology. The use of technology in education results in increased productivity through human capability. Educational technology has to be understood as a science of techniques and methods, by which educational goals can be realized, which makes it easy to adopt modern technologies for improving the effectiveness of the educational process. Consequently, machines and newer techniques are being employed in all areas of knowledge: preservation, transmission and advancement. This extends educational technology across wider boundaries. However, we need to understand that technology within the confines of the classroom has many advantages as well as disadvantages. The disadvantages include absence of adequate training, restricted access to technology and extra time wasted in implementing new technologies. For better understanding of educational technology, it is important to be familiar with the theories of human behaviour, and how behaviour gets affected by technology. This necessitates the adoption of a systematic procedure for using technology in the classroom at a narrow

NOTES

level and the whole educational process at a broad level. This gives way to different approaches to educational technology.

Educational technologies are not distinct technologies but intricate combinations of hardware and software. These technologies may make use of some combination of audio channels, computer code, data, graphics, video, or text. Technology applications are generally recognized in terms of their most noticeable hardware feature (e.g., a VCR or a computer). However, from the perspective of education, the kind of learning imparted is more significant than the equipment delivering it. In this unit, you will learn about the various kinds of teaching aids used in the field of education.

4.1 UNIT OBJECTIVES

After going through this unit, you will be able to:

- Discuss the importance of teaching aids
- Assess the non-projected teaching aids used in classrooms
- Explain the various types of projected teaching aids applied in the field of education
- Analyse the role played by audio-visual aids in the field of education
- Understand the use of a computer as a teaching aid

4.2 TEACHING AIDS FOR TEACHING

‘The supply of teaching aids to every school is essential for the improvement of the quality of learning.’—Indian Education Commission (1964–66).

Education, whatever its specific goals or objectives, involves learning. Learning is a modification of behaviour which has been formed as the result of experiences or prior activities. The basic learning experiences, or the learning inputs, need to reach the pupil through his senses. Senses are known as the gateways of knowledge. Sense experiences provide a basis for intellectual activities. These experiences are gained through several auxiliary medium and materials, which are known as teaching aids. Teaching aids present verbal and abstract experiences in a concrete form, through which learning becomes permanent.

Edgar Dale has presented the relative significance of teaching aids in his book *Audio-Visual Methods in Teaching*, in the form of a cone of experience, as illustrated in Figure 4.1.

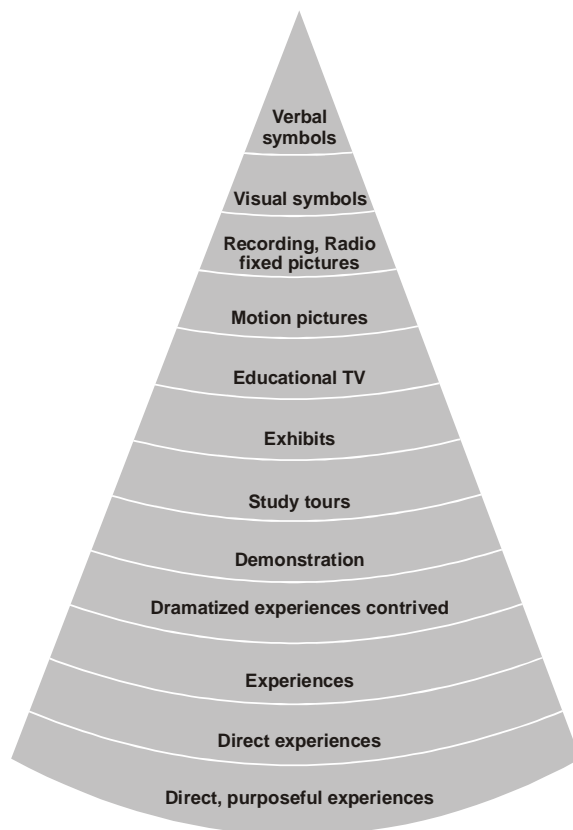

Fig 4.1 Relative Significance of Teaching Aids

The cone of experience encourages direct and purposeful experiences which makes learning meaningful. Intensive direct experiences enable permanent learning.

It is clear from the above figure that verbal symbols are at the lowest level of learning experiences, whereas direct purposeful experiences are considered to be the best. The other mediums are ordered in between these two extremes.

Thus, in order to derive optimum advantage from the application of teaching aids, a teacher should know the place and importance of each of these aids in the teaching–learning process, as well as their utility and methods of evaluation.

Teaching aids can serve as a useful assistant to a teacher. However, these should not overtake or command him under any circumstances. In fact, a teacher should be focussing their operation during the teaching process.

Uses of Teaching Aids in Class

Merely collecting or assembling teaching aids is not a measure of success of the teaching process. It is also essential that these aids are used effectively. To achieve this, a teacher ought to know when and how to use them. If a teacher uses the teaching aids in the manner described below, then it is likely that the outcomes will be suitable, adequate and effective.

NOTES

NOTES

- **Use in stages:** Teaching aids should be used in three stages, i.e., during the introduction, the presentation and during revision. The objective of each of these three stages are different and teaching aids need to be used accordingly.
- **Use as per need:** Teaching aids should be used as and when necessary. If they are used when not needed, the students can get confused. This may also lead to indiscipline in the class.
- **Giving time for thinking and observation:** Teaching aids should not be used only for presentation or demonstration; the students should be given sufficient time for contemplation, observation and learning. Any queries from students should be adequately addressed.
- **Variation in teaching aids:** If the same type of teaching aids are used repeatedly, the students may get bored with them. Hence, there must be variety created by adopting different teaching aids from time to time.
- **Removal of teaching aids after use:** After demonstration and application of the teaching aids, they should be removed and stored appropriately. Also, demonstrating more than one teaching aid at a time may cause confusion in the students' minds.

Procedural Precautions in the Use of Teaching Aids

Teaching or audio-visual aids can be applied effectively if a teacher keeps the following in mind:

- (i) In relation to teacher:
 - The importance and objective of the teaching aids
 - The students' needs and interests
 - The nature of the problem that needs to be communicated
 - The selected teaching aids should be reviewed and edited continuously
- (ii) In relation to classroom:
 - The reason for selecting a particular teaching aid should be explained.
 - The students must be clear as to what is expected of them.
 - New terms and terminology being introduced must be clearly explained to the students.
- (iii) In relation to presentation of material:
 - The presentation should be effective
 - Time management must be appropriate
 - The response of students must be considered
- (iv) In relation to summary:
 - The teaching method should be reviewed and messages summarized from time to time.
 - The suspicions and doubts of the students should be clarified and eradicated.
 - If necessary, students should be tested from time to time.

(v) In relation to feedback:

- The students should be given assignments.
- The students should be given an opportunity to apply the newly acquired knowledge.

A teacher should pay special attention to the following aspects in order to ensure that the teaching aids are used effectively:

- A clear relationship between the aids and the instructional objectives
- Selection of suitable teaching aids
- Suitable opportunity for application of the aids
- Adequate duration for application and experimentation
- Proper arrangements for demonstration of the aids
- Aids should be related to the subject matter and should not be a mere pastime or of recreational value
- They should match the behaviour of the students
- They should be of good quality and realistic
- They should be motivational
- They should be easily available
- They should be useful

A teacher should be careful when applying and preserving teaching aids. He should store them properly, and also take care to rectify defects, if any, himself. It is advisable for him to rehearse an experiment before demonstrating it using a teaching aid in the classroom. He should also be fully trained in the use of teaching aids.

Importance of Teaching Aids in Classroom Teaching

The importance of teaching aids in classroom teaching are is that they:

- Attract the attention of the students quite effectively
- Have a high motivational impact
- Achieve permanent learning within a limited time frame
- Encourage meaningful use of words and reduce verbosity
- Provide a first-hand experience
- Introduce an element of reality into the classroom
- Simplify the work of the teacher
- Reduce the monotony in the classroom
- Reduce the impact of a language barrier in the classroom
- Help to establish continuity in the thought flow
- Improve understanding
- Encourage self-activity

NOTES

NOTES

Principles for Selection of Teaching Aids

The selection of suitable teaching aids is critical for the success of the learning process. An unsuitable selection may result in more harm than good, because this can create confusion in the minds of the students. A teacher should keep in mind the following while selecting teaching aids:

- **Principle of selection:** The selected teaching aids must have certain basic traits. They should be important from an educational viewpoint. They must be interesting and able to motivate the students towards the learning goals. They should be result oriented, i.e., focused on the achievement of the instructional objectives.
- **Principle of preparation:** A teacher should devote himself in making the students psychologically ready for the teaching aids. He must be familiar with the nature of the selected teaching aids. Before he demonstrates the aids in the class, he himself must thoroughly inspect the teaching aids in all respects.
- **Principle of proper presentation:** The teacher should ensure that the subject matter and the teaching aids are coordinated and related. Teaching aids should be used as supplementary tools, and the teacher should be fully proficient in their use.
- **Principle of control:** The teaching aids should be under the control of the teacher during the entire period. There must be no situation wherein the teacher is unable to control or use the teaching aid properly.

4.2.1 Psychology of using Teaching Aids/Audio-visual Aids

In addition to reading, vicarious experience can be gained from still pictures, films, filmstrips, resource persons, simulations, mock-ups, television and the like. The more concrete and realistic the vicarious experience, the more closely it approaches the learning effectiveness of the first level. Of course, unless the learner realizes that he is dealing with a substitute, his learning may not be comparable to that of real-life learning.

Interest in the role of the senses in learning was already there in educational circles when instructional media began their ascendancy. It has long been recognized that the various senses condition the reception of messages in the communication act. Research done by Cobun (1968) indicated that:

- 1 per cent of what is learned is from the sense of *taste*
- 1.5 per cent of what is learned is from the sense of *touch*
- 3.5 per cent of what is learned is from the sense of *smell*
- 11 per cent of what is learned is from the sense of *hearing*
- 83 per cent of what is learned is from the sense of *sight*
- Retention of what is learned is likewise related to the sense experience

Observation and research by Cobun tended to show the holding time as nearly constant as possible, that people generally remember: 10 per cent of what they *read*, 20 per cent of what they *hear*, 30 per cent of what they *see*, 50 per cent of what they *hear and see*, 70 per cent of what they *say*, 90 per cent of what they *say* as they do a thing.

NOTES

CHECK YOUR PROGRESS

1. What does the cone of experience encourage?
2. What are the three stages where teaching aids should be used?
3. Name the principles for selection of teaching aids.

4.3 TYPES OF TEACHING AIDS

The type of equipment used in classrooms have a huge impact on the teaching-learning process. There are different types of teaching aids used in schools today, such as audio-visual, chalkboards, wallcharts, models and so on. We discuss them in detail in the following section.

4.3.1 Non-projected Aids

As the name proposes, non-projected displays comprise every type of visual display that can be shown to a group of students without the use of any optical or electronic projector. They use the most fundamental types of visual aids that teachers and trainers can avail. A few of the popular non-projected displays are discussed in this section.

(i) Chalkboards

These boards are dark in colour, so that chalk can be used to write on them (Figure 4.2). They are the most popularly used visual aids despite the fact that overhead projectors present the same information in a better manner. This is because chalkboards are easy to handle and produce or customize during the course of a lesson; and also to explain calculations and similar exercises to a class of students. It is probably the cheapest and most widely used form of hardware in formal teaching-learning situations. A good chalkboard is 4×6 or 4×7 or 4×8 feet in size, and is made up of slate or glass. It is fixed on the wall at a height of at least 3 feet and is grey, black or green in colour. Now, we also have white boards on which we use multi-coloured pens for writing. These can be wiped off with a damp cloth. These boards are made of wood and their surface is very smooth. A chalkboard provides: (i) a visual presentation of the main teaching points, (ii) a structured record of the content of the session, (iii) a basis for summarizing, (iv) a guide for trainees to take notes from, and (v) additional effect to spoken words or lecture.

NOTES

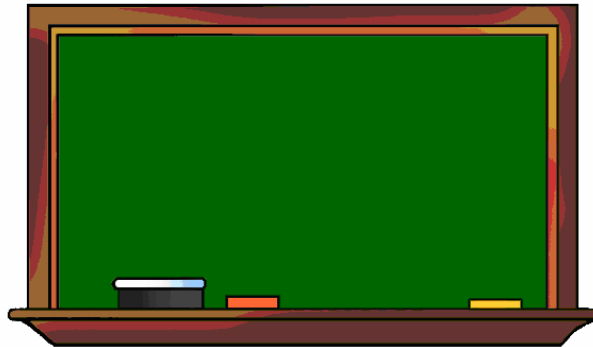

Fig. 4.2 Chalkboard

The advantages of using chalkboard are:

- They are easily available
- They can be used without much advance preparation
- Notes and diagrams can be built up as the lesson progresses
- Points can be added and deleted
- The ideas and words of trainees can be easily included in the summary
- Learners can be involved in writing answers, comments

The unique features and advantages associated with a chalkboard make it the most important and essential aid to teaching and learning in all the subjects of the school curriculum. It is the only aid that is easily accessible to both teachers and students for visualizing the subject matter and diversified subject areas of the school curriculum. When used by a teacher, several points should be borne in mind, such as proper selection of the portion of the chalkboard, regular and proper cleaning of the chalkboard, use of good quality chalks; suitable lettering size for visibility, appropriate angle of writing, and non-traditional use for delivering maximum benefit to students etc.

(ii) Marker Boards

Training halls and teaching rooms often have these boards, which are gradually replacing the conventional chalkboards. These are popularly also known as 'whiteboards'. They are big, white or light-coloured plastic sheets, with surfaces that can be written on. Writing instruments like felt pens, markers or crayons can be used to write on these sheets. Nevertheless, marker boards have the following advantages, when compared with chalkboards:

- There is a lot of mess associated with the usage of chalkboards, even when 'dustless' chalk is used. Marker boards do away with this mess.
- One can use many colours and shades for better, sharper and well-defined display of drawings and written text.
- Unlike a chalkboard, a marker board can work like a projection screen, if required.

One disadvantage of using marker boards on a long-term basis is the difficulty faced when cleaning its surface. After a period of time, writing impressions left behind cannot be erased. Hence, the use of special marker pens is advised, which are recommended by the maker of the board. The board should be cleaned regularly with a damp cloth dipped in the specific cleaning fluid or solvent.



Fig. 4.3 Marker Board

(iii) Electronic marker boards

As technology has developed, electronic marker boards have gained wide acceptance. Electronic marker boards have an edge over manual ones as they can facilitate photo-electronic scan of the written text or drawings on its surface. Some of these boards also have the feature of producing miniature hard copies of the material. Multiple hardcopies can be produced for distribution among members of a class or group. The use of electronic marker boards is limited owing to their high cost.

Some electronic marker boards can scan the material written or drawn on them, so this material can be practically produced and loaded on a communication network and linked with other locations. An appropriate display system can also enable one to view the material from different locations. These types of electronic marker boards offer a suitable platform for interactive communication with distance-learning students. This is the reason that they are so widely used by many educational institutes and universities that offer distance-learning courses.



Fig. 4.4 Electronic Marker board

NOTES

Their utility is much higher for students in remote areas. They are popularly known as ‘smart boards’ in Indian settings.

(iv) Adhesive Displays

NOTES

Adhesive displays also fall in the category of non-projected display media. In these, the material to be displayed is stuck on the surface without the use of drawing pins or glue. Adhesive displays comprise felt boards, hook and loop boards and magnetic boards.

(a) Felt boards

Felt boards are also called flannel-boards or flannel-graphs. These types of boards use shapes cut out of felt, flannel or similar material that can stick to the display surface. They make use of rationally reasonable, easily portable, and very useful technique of display. Felt board are useful for creating both permanent and temporary displays that can be mounted on walls. Nevertheless, they find most appropriate use in exhibited displays like table settings, corporate structures, jigsaw puzzles, and in fundamental mathematical and geometrical concepts.



Fig. 4.5 Felt Board

(b) Hook and loop boards

Hook and loop boards work on the same principle as felt boards. They are also known as teazle boards or teazle-graphs (Figure 4.6). However, these boards use special material (like velcro), with many tiny hooks attached to it. On the other hand, the display surface has a covering of small loops which can be attached to the hooks. These hooks and loops allow the tagging of heavier display material, as and when required. Hook and loop boards are used on the same lines as felt boards, but the added advantage is the provision to heavy display material.



Fig. 2.7 Hook and Loop Board

(c) Magnetic boards

The magnetic board is also a type of adhesive board. These boards have higher utility and versatility, in comparison to felt boards and hook and loop boards. Different types of magnetic boards are available in the market. The latest version comprises sheets of ferromagnetic material, which are coated with special paint on which one can write or draw using suitable markers or pens. All types of board enable display items made of (or backed with) magnetic material to be stuck to and moved about on their surfaces.

These boards also enable movable display to be supplemented by writing or drawing on them. Thus, with the help of magnetic boards (Figure 4.7), highly complicated and refined displays can be created. These displays enable users to clearly exhibit movement and change in systems. They operate as an excellent medium to demonstrate a teaching strategy or to conduct sports related training. To create an exhibit for a basketball or a football team, a permanent field can be painted on the board. Magnetic discs can be used to identify every player. Each magnetic disc can be rearranged and moved around, as and when required. Appropriate arrows and lines made by chalk or marker pens can be used to express different movements, and run patterns.



Fig. 4.7 Magnetic Board

(v) Charts, Posters and Flat Displays

Different forms of charts, posters and other flat pictorial displays have a high usage and versatility among teachers and instructors. We learn about some of the important varieties in this section.

(a) Flip charts

Flip charts are one of the simplest flat type displays. Information can be effectively displayed to a class or a small group of learners through flip charts. These comprise several large sheets of paper, which are attached to a support bar, easel or a display board with the help of clamps or pins. This makes it possible to flip the charts backward or forward, as per the requirements of the teaching–learning situation. There are two basic uses of such charts. A sequential progression of already designed sheets can be displayed through flip charts. This can be done in the desired sequence

NOTES

by flipping one sheet over the other. The following precautions should be kept in mind while preparing flip chart sequences:

NOTES

- The message on every sheet should be easy to understand.
- All that is written or drawn on every sheet should be visible to every member of the core group.
- The print quality and size should be inspected by the teacher/trainer by viewing it from every part of the room.

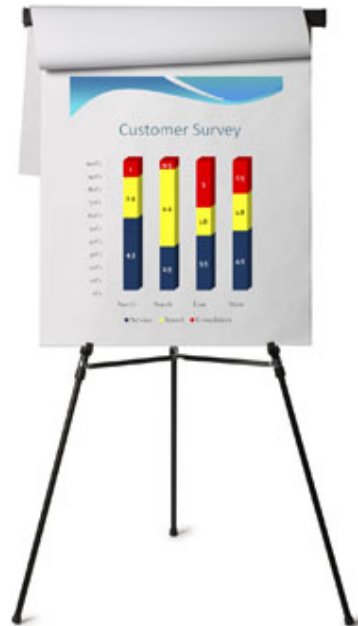

Fig. 4.8 Flip Chart

Flip charts are also useful to jot down content spontaneously during the course of a session or training. They can also be used to make a listing of responses, questions and ideas from learners or concerned groups.

(b) Wallcharts

Different forms of wallcharts are used in every sector of education and training. They are widely used because they are versatile and simple. They have entered the teaching–learning scenario in the sophisticated form of visual aids. Charts and wallcharts cannot be differentiated clearly. In simple terminology, any chart that can be put up on a wall or a noticeboard can be called a wallchart. The main purpose of wallcharts is the area of casual study outside the context of a formal session. The information on charts has a higher level of clarity, when compared to that on wallcharts. In addition to this, they differ in their usage and construction. The common factors in both wallcharts and simple charts is that their sizes can vary and they can comprise more information when compared to overhead transparencies or a 35-mm slide.

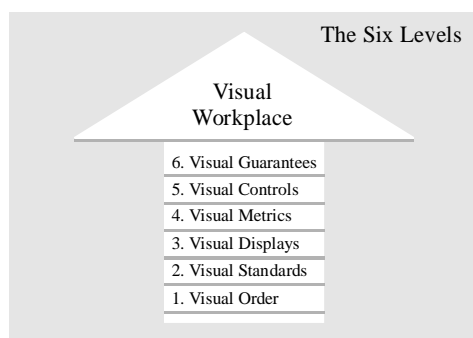

Fig. 4.9 Chart

Charts offer the following advantages:

- Clean presentation
- Portability from one place to another
- Availability of material for summing up

The drawbacks of charts are as follows:

- Limited space on each sheet
- Need to be stored carefully to avoid folds
- Cannot add or remove matter from the sheets
- Are not very durable

Charts can be used to explain important concepts and for recapitulation. Charts that can be referred to learners for content, as and when required, are called 'reference charts'.

(c) Metaplan charts

The metaplan system consists of lightweight pinboards like those made of thermocol, brown sheets, thick cards in different shapes and colours. Other materials used in these charts are felt-tipped markers and glue.

In this system, the participants are asked questions relevant to the theme of the session and to write their views on cards. These cards are collected and shuffled to ensure anonymity. Then they are read out and pinned on boards. It helps to get a collective view of ideas from those involved. Pinboards can be as large as blackboards. The number of pinboards required will depend on the number of trainees, and themes. Normally, two to three boards are required for each session or theme. If there are 24 participants who are divided into three groups and three sessions to use the metaplan system, nine boards will be required. Both sides of the board can be used, which gives flexibility and space.

(d) Posters

S. K. Mangal, in his book, *Teaching of Social Studies*, defined poster as 'a graphical representation of some strong emotional appeal or propaganda carried out through a combination of graphic material like pictures, cartoons, lettering, and other visual art on a placard, primarily intended to catch and hold the attention of the viewers and then forcefully conveying and implanting in their mind a specific fact, idea or message.'

NOTES

NOTES

Since a poster is designed to make a public announcement of a special idea, it usually includes an illustration with a brief caption. It supports local demonstrations, exhibits or activities. The purpose served by a poster can be as follows:

- Catch attention
- Create an impression of a fact or an idea
- Stimulate to support an idea
- Motivate to seek more information and to move towards action

They can be specifically used at different stages of delivering a lesson. Similarly, they can also be used in presentations, practice and recapitulation stages to focus attention of the learner on some specific idea, event or process. A good poster usually concentrates on a single idea and shows a unity of purpose. It is quite helpful in effectively impressing inherent facts, ideas or messages on the minds of children.

(vi) Three-Dimensional Display Materials

Display materials discussed till now were all two-dimensional displays. This section discusses a group of non-projected displays, which are three-dimensional. Non-projected displays are divided into three categories: (i) mobiles, (ii) models, and (iii) dioramas.

(a) Mobiles

Basically, a mobile is a three a three-dimensional wallchart. However, individual components of this wallchart can be moved around. This is a system where pictures, words, can be drawn on card or stencilled on some metal. Fine threads can be used to hang them separately after cutting them, instead of hanging them on a wall. The resulting display is capable of changing shape and direction, in response to air currents. These displays can be hung from any corner of a room where they are visible to anyone who enters the room.

(b) Models

Models can be identified as three-dimensional representations of real or abstract items. A broad range of instructional and teaching–learning situations make extensive use of models. They are primarily used as:

- Visual support material for large-scale education
- Objects for study or manipulation in individual learning
- Construction projects for individuals, small groups or entire classes.

Models are more specifically used to:

- Modify objects so that they can be easily observed and handled; this includes both reducing very large objects and enlarging very small objects
- Clearly demonstrate interior structures of objects or systems as two-dimensional representations are not capable to give this degree of clarity. Products of virtual-reality that provide this clarity are very expensive

- Exhibit movement, which is not possible in case of two-dimensional displays
- Display complex parts of a process in a simple way for learners to understand; by focusing only on significant areas and eliminating all that is complex and causes confusion

Instructors or teachers should keep in mind that if viewed from a distance, even three-dimensional displays appear like two-dimensional ones. Hence, the distance of the learners from a model should be optimum for them to view it clearly.

(c) Dioramas

Dioramas are still-display systems which can combine three-dimensional foreground images with two-dimensional background. The effect thus created is realistic. They can be used to teach a number of subjects, including:

- Biology and natural history (showing plants or animals in their natural environment)
- Architecture, geography and geology (showing buildings, cities, surroundings, primitive landscapes, sites, etc.)
- History, theatre, spiritual learning (illustrations of scenes from history or drama, stage sets, battles, etc.)

CHECK YOUR PROGRESS

4. What are the features that a chalkboard provides?
5. What are adhesive displays?
6. What is unique about magnetic boards?
7. What are flip charts?
8. Define reference charts.

4.3.2 Projected Aids

Visual displays that are without movement are known as still projected displays. These displays rely on optical projectors. The visual aids involved in still projected displays are discussed in this section.

(i) Overhead Projector

An overhead projector (OHP) is a machine which projects light from a lamp through a transparent surface, onto a wall or a screen. The transparent surface (transparency) is the small sheet of plastic that has text or drawing on it. This writing or a drawing appears much enlarged and in exact form and shape, on a blank surface (wall). It helps a teacher to explain a point to the learner with the help of a visual.

NOTES

NOTES



Fig. 4.10 Overhead Projector

Principle: Light is furnished by a 500 to 1,000 watts lamp, and is reflected upward to a projection stage or screen and into an objective lens, which is centrally supported above the stage. The light strikes a mirror and is reflected onto the screen behind the operator. The lens and mirror stand above the machine. The machine may rest on a desk or it may be on a projection stand, or table. Thus, the teacher may sit or stand in front of the class. The screen can be a flat, smooth, white/pale wall. A good and inexpensive screen can also be made from a hardboard. The rough side of the hardboard should be covered with two coats of white emulsion paint. This board may be hung in one corner of the room. The screen should not be reflective.

An overhead projector provides educators with an easy, low-cost interactive environment. Plastic sheets are used as teaching material, which facilitate the educator to write on them with the help of non-permanent and washable coloured board pens. These transparencies can be pre-printed and used in repetition. Thus, they save a lot of time for the teacher or any other user.

The overhead placement should be such that it is convenient for the instructor to use. Further, the educator should be able to face the class, to facilitate better interaction with the students. Since the projector is able to enlarge small script, the educator can write in his own desired font size. He does not need to continuously stretch his arm to write on the board. Unlike a blackboard, time is not wasted in erasing what has been written. Once transparencies are used, they can be restored to their original unused state after washing them with soap and water.

Advantages of overhead projector

An overhead projector has the following advantages:

- When using OHP, a teacher can always face the class and thus maintain eye contact with the students.
- Pre-prepared matter can also be displayed with the help of OHP.
- OHP transparencies can be used repeatedly, which gives the teacher more time to engage in discussions with learners.
- The subject displayed on OHPs also helps learners to retain the lesson learnt.
- Many techniques (free-hand writing or drawing, typing, photocopying, desktop publishing and so on) can be used to prepare OHP transparencies.

- In comparison to other types of visual aids (e.g., charts), overhead transparencies are relatively compact and can thus be easily stored in suitable boxes, large envelopes, folders or files.
- All the lights of a room need not be switched off when using an OHP. This enables students to take notes.
- Small objects may be shown on the machine simply by placing them on the projection stage. They will be projected as silhouettes.
- No extra projectionist or person is required to project.
- The clarity of display in a OHP is higher than that on a blackboard.
- The instructor may prepare an entire course which is time saving.
- The operation of OHP does not require any technical skill and knowledge making it user-friendly. Moreover, it is also clean and quiet.

NOTES

Disadvantages of overhead projector

The disadvantages of overhead projector are as follows:

- OHPs run on electricity and require white surfaces for projection.
- When compared to chalkboards, their maintenance is somewhat time-consuming.
- They have a tendency to break down at times.
- Light from the projector can be irritating.
- Sometimes, positioning of the screen becomes difficult.
- Any error in spelling or pictures are magnified and distract the participants.
- Efficient usage of OHP requires sufficient time, effort and display material in the form of transparencies.

Basic instructions for using OHP

The following basic rules need to be followed for making optimum use of OHP:

- The appropriate positioning of the projector and the screen is of utmost importance. They should be placed in such a manner every participant is able to see the screen easily. Generally, the screen should be placed in one of the front corners of the room, because that leaves the teacher with access to the fixed chalkboard or marker board, which he/she might need at anytime during the session.
- The placement of the projector and screen should reduce or do away with two forms of keystoneing. One form of keystoneing emerges when the axis of projection is not horizontally perpendicular to the screen. This can be reduced when the projector is kept opposite to the centre of the screen. Another form of keystoneing emerges when the axis of projection is not vertically perpendicular to the screen. Often, this can be lessened to a reasonable extent if the screen is tilted forward a bit. If the screen is fixed vertically, the problem can only be resolved by raising the level of the overhead projector. However, this should not block the learners' view of the screen.

NOTES

- The distance of the projector from the screen should be adjusted in such a manner that the entire screen covers the image proportionally, when in proper focus. If the focus is not proper, the people sitting far away from the projector will not be able to see the details on the screen clearly.
- The surface of the lens should be clean and dust-free. Dusty surface of lens make the images opaque. It is recommended to use methylated or surgical spirit and soft cloth to clean the lens.

(ii) Slide Projector

Slide projector or diascope is popularly known as ‘magic lantern’. It is an optical aid to the process of teaching. It is used for projecting pictures from a transparent slide onto a wall or a screen. Since it is used to project slides, it is called a slide projector. A slide projector is useful for small as well as large groups. It comprises four sections: (i) electric incandescent light bulb or similar source of light (usually fan-cooled), (ii) reflector and ‘condensing’ lens to focus the light onto the slide, (iii) a holder for the slide, and (iv) a focusing lens. It helps to project a larger image of the slide. When the figure or illustration is very small and it is required that the whole class should see it clearly, a transparent slide of this small figure is prepared. The slide is placed inverted on the slide carrier of the magic lantern (slide projector). The slide projector projects its erect image on the wall or screen by enlarging its dimensions and making the vision sharper and clearer. A coloured slide or filmstrip is more attractive.

Filmstrip projector works on the principle of direct projection. Light rays emerge directly from the projection lamp or other source of illumination, pass through condenser lenses, the filmstrip/slide and the objective lens to produce an enlarged image on the screen. The source of light can be an electric bulb or a kerosene or petromax lantern. Images are directly projected as they are, when a filmstrip/slide is used. This allows them to be projected even if the room is semi-darkened, at a desired speed.



Fig. 4.11 Slide Projector

Advantages of slide projector

The advantages of slide projector are as follows:

- *Educational information:* The slide projector has immense educational value because of the variety of information it can transmit like maps, drawings, diagrams, and photographs. It enables a subject to be taught clearly and in detail. To make it more effective, a tape recorder can also be used along with the slide projector. The teacher can record a narration on a tape recorder and synchronize it with the slide projector such that it gives the necessary commentary pertaining to the slide without the teacher's intervention.
- *Motivational force:* It arouses the attention and interest of students. A projected image is more effective in capturing the attention of the audience for a longer duration. It is the best way to motivate students towards better learning.
- *Easy to transport:* Slide projectors are light and easy to transport.
- *Easy to use:* Slide projector is easy to use. It is a simple device that can be operated and focused using a remote control.
- *Consistency of images:* Images can remain on the screen as long as the students want them to.
- *Interesting:* The whole activity arouses interest in students.
- *Economical:* There is no wastage of time and energy.
- *Inexpensive:* Slide projectors are not costly. Any school can afford it.
- *Non-fragile:* It is not easily broken.
- *Non-inflammable:* It is non inflammable.

Disadvantages of slide projector

The disadvantages of slide projector are as follows:

- *Not always suitable:* Every type of material cannot be projected by the slide projector.
- *Not excessive use:* Since glass slides are becoming expensive now, the slide projectors may not be used excessively.

(iii) Filmstrips

Filmstrips may be used in slide projectors as well as filmstrip projectors. Instead of using different slide for different topics or more slides for one topic, one strip or piece of still film is prepared. Slides produced on films are called filmstrips. A filmstrip is made of cellulose acetate and is 16 mm or 35 mm wide and 2 to 5 feet long. It usually consists of 40 to 100 separate pictures related to a particular subject, topic or theme. These pictures may be connected with series of drawings, photographs, diagrams, or combination of these. Such a strip or a piece of still film serves the same purpose as served by a number of slides.

NOTES

NOTES



Fig. 4.12 Filmstrip Projector

In a slide projector we use separate slides, while in a filmstrip a strip of film (having many slides) is exhibited. The filmstrip projector is a recent development and it is becoming a more popular means of pictorial representation. Various commercial firms sell such readymade filmstrips for different topics of different subjects for different age groups. Filmstrips are also available on loan, free of charge from the Central Film Library, Central Institute of Educational Technology and NCERT.

Advantages of filmstrip

The advantages of filmstrip are as follows:

- It is easy to operate
- A frame may be held on the screen as long as it is required
- Strips of educative value, according to special needs, are available
- It is possible to review previously exhibited frames again for reference
- It can be used to transmit varieties of information
- Now filmstrips are available with commentary recorded on tapes
- The teacher can also record his comments and play the tape, synchronizing it with the frame of the filmstrip
- Filmstrips are light in weight and easy to carry
- Even a low voltage lamp can serve the purpose while using filmstrips
- With every filmstrip projector, a 2×2 slide attachment is also provided and the same projector can also be used for projecting slides
- Its use does not restrict the normal flow of conversation between the teacher and the class
- Numbered filmstrips are advantageous for the learner, especially when one or two students use them in independent work. Numbering makes it possible to locate the frames
- Since filmstrips present pictures in a fixed sequence, they provide a structure for the subject
- Filmstrips provide economic means of presenting information

Disadvantage of filmstrip

Filmstrips lack audition: The teacher has to work like a commentator along with the filmstrip being projected.

(iv) Epidiascope

An epidiascope projects small opaque images of maps, photographs, and pages of a book on a screen, in an enlarged manner. It is a combination of an episcopescope and diascope. The epidiascope works by reflecting light from an opaque surface (opaque projection). A lamp illuminates the material. The image is reflected by a mirror, through a lens onto the screen.



Fig. 4.13 Ross Epidiascope

It is used for making classroom teaching more interesting and effective. This device does not require slides. Teaching aids like maps, charts, small pictures, graphs, line drawing are directly projected on the screen. The size of small pictures can be magnified or enlarged by the epidiascope. In epidiascope slides, transparencies are also used. It also facilitates books and original matter or teaching aids to be directly projected on the screen. Therefore, the epidiascope is commonly used in classroom presentations. It also makes lessons interesting and effective.

Advantages of epidiascope

The epidiascope has general and specific advantages:

General

- Easy to handle
- Projects a wide variety of materials in a magnified form
- The colour of object is also transmitted onto the screen
- Teachers can have time for class discussions
- Often, an excellent outlet for creative work
- It has a robust mechanism

Specific

- Photographs and pictures can be projected (these are difficult to draw)
- Teaching material can be directly projected from books or other original sources
- Small objects can be projected after demonstration

NOTES

NOTES

Disadvantages of epidiascope

Some of the limitations associated with epidiascope are as follows:

- Pages must be flat when books are being used
- Materials sensitive to heat is to be avoided
- Projection by reflected light is less efficient and requires total darkness
- Machine is too bulky to be easily carried
- The operator cannot face the audience
- Projector must be kept near the screen
- Expensive in terms of cost

Precautions to be kept in mind while using epidiascope

- Before teaching, the epidiascope and the screen should be set in the classroom properly.
- It requires a dark room for projecting teaching aids so that proper arrangements should be made for the purpose.
- The size of teaching aids should be according to the size of the epidiascope's aperture.
- The teacher should give his comments simultaneously while projecting the teaching material.
- The teacher should make use of a pointer for indicating the aspects of a diagram or picture.

(v) Microfilm and Microfiche

Microfilms are 35-mm films, which contain photographed reading material. Each frame contains materials of one page. The rolls of microfilm are placed in microfilm readers which project each page on a revision screen. Microfiche is a miniature form of microfilm. This is a sheet of film carrying many rows of images of printed matter. Microfiche is reduced in size, in comparison to microfilm. Both microfilm and microfiche can be stored, retrieved, and projected for reading. They have great educational potential.

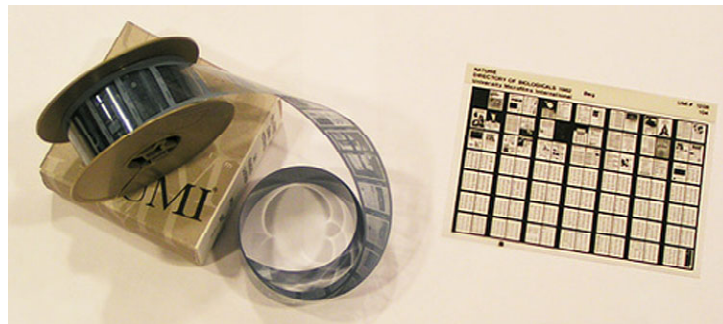

Fig. 4.14 Microfilm and Microfiche

CHECK YOUR PROGRESS

9. What is the advantage of using an overhead projector?
10. Why a slide projector is named so?
11. List three advantages of a filmstrip projector.
12. How does an epidiascope work?
13. What is the miniature form of microfilm known as?

NOTES

4.3.3 Audio-visual Aids

Electronic resources have also made their foray into the field of education, in the last century. In 1920 it was the radio, and in 1950 the television began to be used widely as educational tools. The usage of radio and television in broadcasting for education has assumed three general approaches:

- *Direct class teaching*: Where temporarily, teachers are replaced by broadcast programming substitutes
- *School broadcasting*: Where complementary teaching and learning resources are offered by broadcast programming
- *General educational programming*: Which offers general and informal educational opportunities

This section would discuss both of these electronic resources in brief.

(i) Radio

Radio basically transmits signals through free space enabled by modulation of electromagnetic waves having frequencies lower than visible light. This is done by oscillating electromagnetic fields that pass through air and the vacuum of space, which makes electromagnetic radiation travel. By systematically changing (modulating) some property of radiated waves, such as amplitude, frequency, phase, or pulse-width, information is carried from one place to another. The oscillating fields induce an alternating current in the conductor, when radio waves pass an electrical conductor. This can be detected and transformed into sound or other signals that carry information.

According to Butcher (2003), 'radio has been used in education ever since its availability'. Pennycuick (1993) of the Centre for International Education at the University of Sussex, states more specifically that interactive radio instruction (IRI) is characterized by 'highly coordinated' instructional materials and delivery strategies. It includes elements of active participation on the part of the students. In spite of technological advancements, radio remains the key media to which most rural people have access. Educational radio initiatives in different developing countries were effective in providing topical programmes and reaching large numbers of learners rapidly. Further, radio broadcasting is one of the greatest educational tools, which has ever been placed at the disposal of civilized man. It is an instantaneous and

NOTES

universal means of communication. Broadcasting is relatively new, as far as its age is concerned. However, in a short period, it has been determined definitely that it can perform three separate major functions— (i) it can sell goods and services; (ii) it can provide entertainment; and (iii) it can make education, culture and information available. Radio can be educative in formal as well as informal situations. The medium of radio is very effective for broadcast of lectures by eminent educationists, scientists, and historical statements. It is a rich medium for broadcast of drama, stories, commentary, sports news, educational news and educational programmes. It is popular in both urban and rural settings. Radio programmes are generally prepared on topics which are more suitable to verbal communication. In India, AIR and other radio channels render valuable assistance to classroom instructional programmes. The limitations of radio broadcasting are:

- It uses only the sense of hearing
- It is a one-way communication

(ii) Television

Education television excels as a medium of large-scale delivery of information. In modern times, television is an integral part of our culture. TV provides entertainment, news, education, culture, weather, and sports. Television is the most powerful medium of mass communication that has ever existed and it has revolutionized our life in many ways. It appears that the future television is going to have definite positive contribution to make children's life in the classroom happy (M. J. Apter). Television is already widely being used in schools. It is a powerful medium of communication that calls for the use of auditory as well as visual sense of learners in receiving education.

Television offers many benefits to children and learners in general, including:

- TV enables the sharing of cultural experiences and thus brings the world closer.
- In Indian setting, specifically where bonding is valued, viewing of programmes gives the family members of all ages, an opportunity to spend time together.
- Television can be used by parents as a catalyst to get children into the habit of reading. This can be done by following up televised programmes through books on same subjects.
- Exhibiting social responsibility, television can spread cultural and family values in an implicit manner.
- Television programmes provide an opportunity to parents to explore and discuss controversial or sensitive issues with children.
- Learning skills and even socialization of young children can be developed through balanced and efficient use of educational programmes.
- Young people can become more aware of other cultures and people through news, current events and historical programming.
- Documentaries can give rise to judgmental thoughts concerning society and the world.

- The world of art and music can be opened for people by cultural programming on television.
- Televised instructions have the potential of improving the process and products of learning as they involve thorough planning, systematic presentation and integration of a wide range of audio-visual material and appliances.

Television is an important aid to teachers, supervisors and educational planners. It has been utilized for informal and formal education and for distance and correspondence education. There are some limitations associated with television in the form of one-way communication, impersonal nature, passive learning, no interaction, and expensive media.

India, like other developing countries, has been using television for enriching and improving the quality of education at every level. It has been particularly used for expanding educational facilities, particularly in rural and backward areas, for normal and informal systems. New dimensions have been added to the use of television for instructional purposes with the advent of satellites. So far there has been use of open circuit television in India. Closed circuit use of television for educational purposes has not been explored much. Closed circuit television broadcasting is a sort of micro-level local arrangement limited to a single school, or several schools located in a particular region. The schools are connected by a cable or microwave system. The telecast cannot be received outside the selected network and signal is not required to meet the commercial broadcasting regulations.

(iii) Closed Circuit Television (CCTV)

Television systems have assumed an important place in our daily life as it is one of the most indispensable means of information and communications. Television broadcasts are a form of 'open-circuit system', which are accessed by indefinite number of people. Another form of circuit systems are 'closed-circuit systems', which are designed to provide video to specified viewers. CCTV system is a system that has been primarily designed for surveillance purposes. CCTV is very useful in areas associated with security, disaster prevention, energy and manpower saving, sales promotion and information services, production management, industrial measurement, medical care, education and military fields. Specifically in the field of instruction and education, CCTV has a wide applicability. It enables schools or institutions to develop and allow their students to access specific programmes that are needed for their overall growth and development.

The definite advantages offered by CCTV have been highlighted as follows:

- Many CCTV systems are suited for distant viewing. The images broadcasted by them probably comprise photographs from space, snapshots of furnaces or other industrial equipment, and biological hazards.
- The use of CCTV would ease the shortage of good instructors or teachers, reduce instructional costs, provide uniform instructions to a large number of students simultaneously, and facilitate repetitive representation of resource persons or material.

NOTES

- The use of CCTV provides a platform for desired exchange of man-material resources, learning and instructional activities, courses and events not only among students and staff of the same institution, but also among various institutions on the network of CCTV.

NOTES

(iv) Video Cassette Reorder

The **Video cassette recorder** (VCR) is an electronic device that plays VHS or beta tapes containing recorded movies and other programmes (like music videos, exercise videos, etc.). A VCR has to be connected to a TV for viewing a recorded programme. A number of variants of VCR have been produced over the years, in addition to the traditional home VCR. These include combined 'all-in-one' devices such as the televideo (a TV and VCR in one unit) and DVD/VCR units and even TV/VCR/DVD all-in-one units. A camcorder merges a video camera and VCR in one machine.

VCR can not only play pre-recorded cassettes, but also record any programme and replay it. Thus, educational television programmes can be recorded and later on shown to students. With the help of video cassette recorders, educational and other useful events can be recorded for teaching purposes. The replay of those programmes in colour makes viewing very interesting and leaves a considerable impact on viewers.

Advantages of VCR:

The advantages of VCR are as follows:

- The operation of a video cassette recorder is very simple.
- It is portable and can be moved from one place to the other easily.
- Knowledge acquired by video is permanent.
- It is helpful to students in providing them knowledge of social and political conditions of different countries.
- It is helpful in developing the thoughts and reasoning power of students.
- It is equally useful for children of varying abilities.
- The teacher can remove the doubts of students simultaneously, which is not possible in a television lesson.
- The teacher can control the video presentation.
- Pictures on a VCR can be repeated as many times as required.
- Video films on different teaching subjects are easily available.

(v) Motion Picture

A **motion picture** (sometimes called a movie or film) is a series of still pictures (frames) usually 8 mm or 16 mm in size, taken in rapid succession. When projected by a motion picture projector, they give an illusion of motion (Gerlach and Ely, 1980) Films vary in length from one minute or less, to 50 minutes or more. If a 6-mm motion picture runs for more than 50 minutes in length, it is usually stored on two or more reels. The speed at which a film is projected varies with the format of

the film. A sound 16-mm film is projected at 24 frames per second (fps) and super 8-mm films, at 18 fps. Therefore, it is possible to show films in such a manner as to create three types of images:

- Normal motion
- Fast motion
- Slow motion

Motion pictures are very useful in teaching various subjects like literature, drama, history, geography and science subjects. Motion pictures motivate students as they enjoy the medium. They bring people, country, events, on the screen. However, they are expensive and subject to damage, if used extensively.

Hoban and Ormer have revealed the following educational advantages of motion pictures:

- Good films can be used as sole means of imparting certain factual information and developing performance skills.
- Pupils will change or develop attitude and opinions, as a result of viewing films.
- Pupils will learn more from films if they are properly prepared and motivated.
- Learning will increase with repeated screenings of a film. Short single-concept films have certain advantages.
- Pupils can develop the will of problem-solving by viewing well-produced films.
- The ability to learn from films will increase with practice.

Amidst these advantages, it should not be assumed that learning would occur only by watching films. The method of presentation may be inadequate or the film may not be suitable for students of a particular age. Therefore, sufficient care should be taken while selecting a film. It should be borne in mind that films with built-in viewer participation and repetition of key points increase learning. If these factors are lacking in a film, then these should be supplied by the teacher during or immediately after screening of the film.

(vi) Tape Recorder

An **audio tape recorder**, tape deck, reel-to-reel tape deck, cassette deck or tape machine is an audio storage device that records and plays back sounds, including articulated voices. It usually uses magnetic tapes, either wound on a reel or in a cassette, for storage. In its current form, it records a fluctuating signal by moving the tape across a tape head that polarizes magnetic domains in the tape, in proportion to the audio signal. There are many types of tape recorders in existence, from small hand-held devices to large multi-track machines. A machine with built-in speakers and audio power amplification to drive them is usually called a 'tape recorder'. If this machine does not have the record functionality, it is a 'tape player'; while one that requires external amplification for playback is usually called a 'tape deck' (regardless of whether it can record).

NOTES

NOTES

The invention of tape recorder has brought about a revolution in the teaching–learning process. Its main function is recording and reproducing of sound. Microphone, amplifier and reproducer are its three parts. It is an instrument which is used to record speeches, songs, and music. It may be played back at any time and any number of times. Teaching with tape recorder is an extension of a teacher’s work.

The educational utility of tape recorder in education has been highlighted in the following points:

- There is no fixed time schedule for tape recorded programmes and thus, no changes are required in the school timetable. It can be used anytime and anywhere.
- It helps in supplementing the educational output of radio and television broadcasts and guest lectures.
- Recorded educational programmes can be used for instruction in schools and colleges.
- It helps students in developing oratory skills by repeated practice. Further, it helps in overcoming poor speech habits and correcting speech defects.
- Tape recorders are immensely used in developing conversation skills, expression power and techniques of dramatization.
- They are significantly used in teaching specific subjects like music, dramatics and language.
- They are also used in organizations for conducting and evaluating various co-curricular activities.
- They may help in modification of behaviour and for encoding classroom events.
- They can supplement other educational tools like projectors, video players.

A tape recorder is very easy to operate and useful in group teaching as well as individual learning. It is also easy to erase a recording, if not required.

4.3.4 Computer as a Teaching Aid

A computer is an electronic device that accepts data, performs operations on it in a sequence (decided by a programme) and gives the resulting output. Computers can be of various sizes and types like mainframe computers, mini-computers and microcomputers. Apart from size, computers are differentiated according to their specifications. These specifications include the amount and type of storage, capabilities of the Central Processing Unit (CPU), and type and nature of the peripheral equipment (such as disc storage) that can be connected to it.

A computer has several applications in instructional situations. It is used to analyse the level of knowledge in entry level students, at the time of enrolment. It is also used to plan and print individual programmes, monitor a student’s progress and compile tests and scores. Computers are aid to the instructional process of education. In terms of technological advancement and educational utility, they have surpassed all the audio-visual aid material and equipment. The demand for computers is increasing day by day, at all levels of education.

In various forms and at various levels, computer technology has been able to make a strong impact on education. The advantages of computers in education include efficient storage and rendition of information, quick information processing, and the most important benefit being saving of paper.

Some of the characteristic features of application of computers in education are:

- Modern systems of education have been greatly influenced by the usage of computers. Students find it easier to refer to the Internet for searching information rather than look for it in books. The process of learning is not limited to learning from prescribed textbooks, it is much more.
- Computers have played an essential role in promoting education to a large number of learners. By taking education outside the classroom, this technology has made the dream of distance learning a reality. It has been able to bridge geographical barriers in the process of education. In other words, computer networking has brought physically distant locations closer. This has benefited all those, who are in the field of education.
- Efficient storage and effective presentation of information has been enabled by use of computers. There are several presentation software like PowerPoint and animation software like Flash, which have proved to be of immense help to teachers while delivering information.
- Computers have the potential to add an element of fun to education. It is a good break from the monotony of 'chalk and talk' classes. They can turn out to be a brilliant aid in teaching, if used properly. Computers facilitate making the process of learning interactive and interesting by audiovisual presentation of information.
- Computers have helped in going 'green'. They help in saving paper by facilitating an electronic format for storage of information. There have been instances where schools have gone far and even collected homework and test assignments as soft copies and thus saved paper. It is well known that electronically erasable memory devices can be used repeatedly. They offer a robust storage of data and reliable data retrieval techniques. Computer technology thus eases the process of learning.
- The Internet can play a significant role in different aspects of education. Being a colossal information base, it can be used well for retrieval of information on a wide variety of subjects. There is not a single subject taught to students for which the Internet cannot be used to gather information.

Though computers have contributed in different spheres of education, the most important contribution is in the domain of instruction; in the form of Computer Assisted Instruction (CAI) and Computer Managed Instruction (CMI). Here, it needs to be emphasized that computers should be used as an educational tool, rather than a means of education. Nothing can replace interactions between students and teachers.

NOTES

NOTES

CHECK YOUR PROGRESS

14. What are the limitations of radio broadcasting?
15. What are the limitations associated with television?
16. What is a video cassette recorder?
17. What is a computer and what are its types?
18. How have computers helped in going 'green'?

4.4 SUMMARY

- Education, whatever its specific goals or objectives, involves learning. Learning is a modification of behaviour which has been formed as the result of experiences or prior activities.
- Teaching aids present verbal and abstract experiences in a concrete form, through which learning becomes permanent.
- Teaching aids should be used in three stages, i.e., during the introduction, the presentation and during revision.
- The selection of suitable teaching aids is critical for the success of the learning process. An unsuitable selection may result in more harm than good, because this can create confusion in the minds of the students.
- As the name proposes, non-projected displays comprise every type of visual display that can be shown to a group of students without the use of any optical or electronic projector.
- The magnetic board is also a type of adhesive board. These boards have higher utility and versatility, in comparison to felt boards and hook and loop boards.
- Flip charts are one of the simplest flat type displays. Information can be effectively displayed to a class or a small group of learners through flip charts. These comprise several large sheets of paper, which are attached to a support bar, easel or a display board with the help of clamps or pins.
- S. K. Mangal, in his book, *Teaching of Social Studies*, defined poster as ‘a graphical representation of some strong emotional appeal or propaganda carried out through a combination of graphic material like pictures, cartoons, lettering, and other visual art on a placard, primarily intended to catch and hold the attention of the viewers and then forcefully conveying and implanting in their mind a specific fact, idea or message’.
- Non-projected displays are divided into three categories: (i) mobiles, (ii) models, and (iii) dioramas.
- Dioramas are still-display systems which can combine three-dimensional foreground images with two-dimensional background.

- An overhead projector provides educators with an easy, low-cost interactive environment. Plastic sheets are used as teaching material, which facilitate the educator to write on them with the help of non-permanent and washable coloured board pens.
- Slide projector or diascope is popularly known as ‘magic lantern’. It is an optical aid to the process of teaching. It is used for projecting pictures from a transparent slide onto a wall or a screen. Since it is used to project slides, it is called a slide projector.
- Filmstrips may be used in slide projectors as well as filmstrip projectors. Instead of using different slide for different topics or more slides for one topic, one strip or piece of still film is prepared.
- An epidiascope projects small opaque images of maps, photographs, pages of a book, on a screen, in an enlarged manner.
- Microfilms are 35-mm films, which contain photographed reading material. Each frame contains materials of one page. The rolls of microfilm are placed in microfilm readers which project each page on a revision screen. Microfiche is a miniature form of microfilm.
- Radio basically transmits signals through free space enabled by modulation of electromagnetic waves having frequencies lower than visible light. This is done by oscillating electromagnetic fields that pass through air and the vacuum of space, which makes electromagnetic radiation travel.
- Education television excels as a medium of large-scale delivery of information. In the modern times, television is an integral part of the culture.
- An **audio tape recorder**, tape deck, reel-to-reel tape deck, cassette deck or tape machine is an audio storage device that records and plays back sounds, including articulated voices.
- A computer is an electronic device that accepts data, performs operations on it in a sequence (decided by a programme) and gives the resulting output. Computers can be of various sizes and types like mainframe computers, mini-computers and microcomputers.
- Computers are aid to the instructional process of education. In terms of technological advancement and educational utility, they have surpassed all the audio-visual aid material and equipment.

NOTES

4.5 KEY TERMS

- **Learning:** Learning is a modification of behaviour which has been formed as the result of experiences or prior activities.
- **Non-projected displays:** Non-projected displays comprise every type of visual display that can be shown to a group of students without the use of any optical or electronic projector.

NOTES

- **Whiteboards:** Whiteboards are big, white or light-coloured plastic sheets, with surfaces that can be written on.
- **Adhesive displays:** Adhesive displays also fall in the category of non-projected display media. In these, the material to be displayed is stuck on the surface without the use of drawing pins or glue.
- **Wallchart:** In simple terminology, any chart that can be put up on a wall or a noticeboard can be called a wallchart.
- **Charts:** Charts that can be referred to learners for content, as and when required, are called 'reference charts'.
- **Poster:** A poster is 'a graphical representation of some strong emotional appeal or propaganda carried out through a combination of graphic material like pictures, cartoons, lettering, and other visual art on a placard, primarily intended to catch and hold the attention of the viewers and then forcefully conveying and implanting in their mind a specific fact, idea or message'.
- **Dioramas:** Dioramas are still-display systems which can combine three-dimensional foreground images with two-dimensional background.
- **Still projected displays:** Visual displays that are without movement are known as still projected displays.
- **Overhead projector (OHP):** An overhead projector (OHP) is a machine which projects light from a lamp through a transparent surface, onto a wall or a screen.
- **Epidiascope:** An epidiascope projects small opaque images of maps, photographs, pages of a book, on a screen, in an enlarged manner.
- **Microfilms:** Microfilms are 35-mm films, which contain photographed reading material. Each frame contains materials of one page.
- **Microfiche:** Microfiche is a miniature form of microfilm.
- **CCTV system:** CCTV system is a system that has been primarily designed for surveillance purposes. CCTV is very useful in areas associated with security, disaster prevention, energy and manpower saving, sales promotion and information services, production management, industrial measurement, medical care, education and military fields.
- **Video cassette recorder (VCR):** The Video cassette recorder (VCR) is an electronic device that plays VHS or beta tapes containing recorded movies and other programmes (like music videos, exercise videos, etc.).
- **Motion picture:** A motion picture (sometimes called a movie or film) is a series of still pictures (frames) usually 8 mm or 16 mm in size, taken in rapid succession.
- **Audio tape recorder:** An audio tape recorder, tape deck, reel-to-reel tape deck, cassette deck or tape machine is an audio storage device that records and plays back sounds, including articulated voices.
- **Tape recorder:** A machine with built-in speakers and audio power amplification to drive them is usually called a 'tape recorder'.

- **Computer:** A computer is an electronic device that accepts data, performs operations on it in a sequence (decided by a programme) and gives the resulting output.

4.6 ANSWERS TO ‘CHECK YOUR PROGRESS’

NOTES

1. The cone of experience encourages direct and purposeful experiences which makes learning meaningful. Intensive direct experiences enable permanent learning.
2. Teaching aids should be used in three stages, i.e., during the introduction, the presentation and during revision.
3. The principles for selection of teaching aids are:
 - Principle of selection
 - Principle of preparation
 - Principle of proper presentation
 - Principle of control
4. A chalkboard provides: (i) a visual presentation of the main teaching points, (ii) a structured record of the content of the session, (iii) a basis for summarizing, (iv) a guide for trainees to take notes from, and (v) additional effect to spoken words or lecture.
5. Adhesive displays also fall in the category of non-projected display media. In these, the material to be displayed is stuck on the surface without the use of drawing pins or glue. Adhesive displays comprise felt boards, hook and loop boards and magnetic boards.
6. Magnetic boards enable movable display to be supplemented by writing or drawing on them. Thus, with the help of magnetic boards, highly complicated and refined displays can be created. These displays enable users to clearly exhibit movement and change in systems. They operate as an excellent medium to demonstrate a teaching strategy or to conduct sports related training.
7. Flip charts are one of the simplest flat type displays. Information can be effectively displayed to a class or a small group of learners through flip charts. These comprise several large sheets of paper, which are attached to a support bar, easel or a display board with the help of clamps or pins.
8. Charts that can be referred to learners for content, as and when required, are called ‘reference charts’.
9. Since the projector is able to enlarge small script, the educator can write in his own desired font size. He does not need to continuously stretch his arm to write on the board. Unlike a blackboard, time is not wasted in erasing what has been written. Once transparencies are used, they can be restored to their original unused state after washing them with soap and water.
10. Slide projector or diascope is popularly known as ‘magic lantern’. It is an optical aid to the process of teaching. It is used for projecting pictures from a

NOTES

transparent slide onto a wall or a screen. Since it is used to project slides, it is called a slide projector.

11. The advantages of filmstrip are as follows:
 - It is easy to operate
 - A frame may be held on the screen as long as it is required
 - Strips of educative value, according to special needs, are available
12. The epidiascope works by reflecting light from an opaque surface (opaque projection). A lamp illuminates the material. The image is reflected by a mirror, through a lens onto the screen.
13. The miniature form of microfilm is known as a microfiche.
14. The limitations of radio broadcasting are:
 - It uses only the sense of hearing
 - It is a one-way communication
15. There are some limitations associated with television in the form of one-way communication, impersonal nature, passive learning, no interaction, and expensive media.
16. The Video cassette recorder (VCR) is an electronic device that plays VHS or beta tapes containing recorded movies and other programmes (like music videos, exercise videos, etc.).
17. A computer is an electronic device that accepts data, performs operations on it in a sequence (decided by a programme) and gives the resulting output. Computers can be of various sizes and types like mainframe computers, mini-computers and microcomputers.
18. Computers have helped in going 'green'. They help in saving paper by facilitating an electronic format for storage of information. There have been instances where schools have gone far and even collected homework and test assignments as soft copies and thus saved paper.

4.7 QUESTIONS AND EXERCISES

Short-Answer Questions

1. What are the uses of teaching aids in class?
2. State the importance of teaching aids in classroom teaching.
3. List the advantages of using a chalkboard.
4. What is special about hook and loop boards?
5. List the precautions that should be taken while preparing a flip chart.
6. Enumerate the advantages and the drawbacks of using charts in a classroom.
7. How does S. K. Mandal define a poster?
8. What are the uses of dioramas in a classroom?

9. What is the principle on which an overhead projector works?
10. What is an epidiascope?
11. List the benefits offered by a TV set.
12. What are the advantages offered by a CCTV?
13. How is a movie or film helpful in the education of a student?
14. What are the characteristic features of application of computers in education?

NOTES

Long-Answer Questions

1. 'The supply of teaching aids to every school is essential for the improvement of the quality of learning.' With reference to the statement, discuss the importance of teaching aids.
2. Discuss the non-projected teaching aids used in classrooms.
3. Explain the various type of projected teaching aids applied in the field of education.
4. 'Electronic resources have also made their foray into the field of education, in the last century.' With respect to this statement, critically analyse the role played by audio-visual aids in the field of education.
5. Assess the use of a computer as a teaching aid.

4.8 FURTHER READING

- Aggarwal, J. C. 2009. *Essentials of Educational Technology*. New Delhi: Vikas Publishing House.
- Kochhar, S. K. 1985. *Methods and Techniques of Teaching*. New Delhi: Sterling Publishers.
- Mangal, S. K. 2001. *Foundation of Educational Technology*. Ludhiana: Tendon Publications.
- Sampath, K., A. Panneerselvam, S. Santhanam. 2007. *Introduction to Educational Technology*. New Delhi: Sterling Publishers.
- Shankala, D.P. 2006. *Educational Technology*. New Delhi: Adhyayan Publishers and Distributors.
- Sharma, K. K. 2007. *Educational Technology*. Delhi: Mahaveer & Sons Publishers and Distributors.
- Sharma, R. A. 2002. *Technology of Teaching*. Meerut: International Publishing House.

UNIT 5 STAGES, LEVELS AND MODELS OF TEACHING

NOTES

Structure

- 5.0 Introduction
- 5.1 Unit Objectives
- 5.2 Teaching vs. Training/Instruction/Indoctrination
 - 5.2.1 Teaching/Conditioning and Training
 - 5.2.2 Teaching and Instructions
 - 5.2.3 Teaching and Indoctrination
- 5.3 Levels of Teaching
 - 5.3.1 Memory Level of Teaching
 - 5.3.2 Understanding Level of Teaching
 - 5.3.3 Reflective Level of Teaching
- 5.4 Programme Instruction
 - 5.4.1 Steps for Development of Programmed Instruction
 - 5.4.2 Fundamental Principles
- 5.5 Types of Programmed Instruction
- 5.6 Summary
- 5.7 Key Terms
- 5.8 Answers to 'Check Your Progress'
- 5.9 Questions and Exercises
- 5.10 Further Reading

5.0 INTRODUCTION

According to Ned A. Flanders, the author of *Analyzing Teaching Behaviour*, teaching is interactive in nature. When teachers and students interact, they participate in the process of teaching. In this process, students are influenced by the teacher. Students also interact among themselves. Thus, the process of teaching is where a person interacts with every other person in a class. Teaching should not be confused with training, instruction and indoctrination. However, all these may help in the process of teaching. Teaching is more complex, wide and comprehensive in comparison to all these terms.

Programmed instruction or programmed learning represents one of the effective innovations in teaching-learning process. As a highly individualized and systematic instructional strategy, it has been found quite useful for classroom instruction as well as self-learning or auto-instruction. It is not only a technique for effective learning, but also a successful feedback device for the modification of teachers' behaviour. It provides insight into the problems of teaching through improved feedback and reinforcement mechanism.

In this unit, you will learn about the entire process of teaching. A teacher can present content at three basic levels which are memory level, understanding level

NOTES

and reflective level. All these levels will be studied in detail so that you could comprehend the process of teaching better. You will also learn about programmed instruction and its various types, namely the linear programming, branching programming and mathematics programming. The significance and characteristics of each type will be dealt with in detail in this unit.

5.1 UNIT OBJECTIVES

After going through this unit, you will be able to:

- Discuss the concept of teaching and differentiate it from instruction, training and indoctrination
- Explain the memory level of teaching
- Assess the process of understanding level of teaching
- Analyse the process of reflective level of teaching
- Evaluate the process of programme instruction
- Discuss the types of programmed instruction

5.2 TEACHING VS. TRAINING/INSTRUCTION/ INDOCTRINATION

Following are some of the definitions of teaching by experts in the field.

According to American philosopher of science and of education Israel Scheffler, 'Teaching may be characterized as an activity aimed at the achievement of learning and practiced in such a manner as to respect the student's intellectual integrity and capacity for independent judgement.'

B. O. Smith (1960) defines teaching as: 'A system of actions intended to induce learning.'

In Scheffler's definition, the activities focused on learning have been termed as 'teaching' whether these activities produce learning or not. In Smith's definition, propagandizing and indoctrination of these principles are included which produce learning. Hence, Smith's definition is more comprehensive than Scheffler's even though both the definitions are learning-oriented.

Thomas F. Green (1971) has given a very comprehensive definition of teaching, i.e., 'Teaching is the task of teacher which is performed for the development of a child.'

According to Clark (1970), 'Teaching refers to activities that are designed and performed to produce change in student behaviour.'

Teaching is not a single activity. It can be interpreted in its molecular form. It can be viewed as a family of activities. In this family of activities, every activity becomes important.

5.2.1 Teaching/Conditioning and Training

Usually, the meaning of teaching is expressed in the form of habit formation while training is interpreted as shaping habits. Both these concepts are closely related. However, teaching and training are not alike. Training is a part of teaching. The more the intelligence exhibited in the training programme, more it would be closer to the teaching-process and would resemble teaching. Actually training resembles more with conditioning than teaching. In short, the main difference between training/conditioning and teaching is reflected by the quantity of intelligence used. In the process of training and conditioning, the acquisition of new turn to the human behaviour and the acquisition of various skills are helped. Hence, training and conditioning can produce skilled workers. Students cannot be promoted to the next higher level of education as a result of training.

5.2.2 Teaching and Instructions

Instruction is also one of the activities related to teaching. Sometimes we term instruction as teaching. But instruction and teaching are not the same. There are many examples which convey us that instruction and teaching are different though they are related to each other. A perfect example is—when an activity to teach a dog to stand on its feet or to sit down or to bring some object starts, it would be wrong to term it as ‘providing instruction’ or ‘providing guidance’. Whenever we happen to provide instruction or guidance, it means we are performing the task of teaching. But when we teach, it is not necessary that instruction too is included in that teaching.

Under instruction or guidance, causes are explained, evidences are supplied. In short, instruction or guidance is concerned with understanding. In training, more attention is paid towards habit formation and behaviour development, and less towards the acquisition of knowledge. Hence, the instruction activity is only a small part of the comprehensive concept of teaching. Instructions cannot reach to the high level of teaching. Teaching includes the presence of a teacher, participation of the students and their activeness, while these are not essential in instruction. Instruction is possible through radio, tape-recorder, and television. In the teaching process, such type of material related to the instruction can be used. Hence, all the activities related to the instruction can be included in the teaching process, but the inclusion of entire or total teaching is not possible in the instruction.

5.2.3 Teaching and Indoctrination

Indoctrination is the highest level of teaching. At this level more intelligence is expected. All the great men, politicians, leaders influence other people with the support of their ideology, thoughts, assumptions and beliefs. A teacher can include indoctrination in his teaching. It means it can be made a part of the teaching by including indoctrination in the teaching but it is not enough.

On the other hand, it should also be made clear that teaching can also occur without indoctrination. But without the process of teaching (teaching means, teaching objectives) indoctrination is not possible.

NOTES

In short we can say that conditioning, training, instruction and indoctrination are part of the entire teaching process and they depict the various levels of teaching process.

NOTES

CHECK YOUR PROGRESS

1. Give Israel Scheffler's definition of teaching.
2. Distinguish between teaching and training.
3. What is meant by the term 'indoctrination'?

5.3 LEVELS OF TEACHING

Teaching is a purposeful process which has a close relationship with learning. Therefore, in the modern age, teaching and learning, both, are accepted as one concept. We should remember that each content has its own nature and various teaching objectives. It is to be observed that a teacher can present the content at three levels, from thoughtless to thoughtful situations. These levels are: (i) Memory level (ii) Understanding level and (iii) Reflective level.

Memory level teaching is 'thoughtless'; it is the initial stage of teaching. Understanding level of teaching is the next higher level of memory level teaching. This level includes both memory and insight of the learner. In other words, for understanding the level of teaching, memory level teaching is the pre-requisite. The third and the last level of teaching is reflective level. This level includes both memory and understanding levels of teaching. In other words, for reflective level of teaching, the occurrence of teaching both at memory and understanding levels is essential. In this way, the process of teaching starts from memory level which advances to reflective level after passing through understanding level of teaching. Remember that if the reality of the subject along with its knowledge is to be provided, the content must be taught at all the three levels. It depends on the teacher's competency that to what extent he succeeds in reaching the reflective level starting from the memory level on the basis of his efficiency and experiences. It is a common observation that the normal teaching corresponds to the memory level teaching. Such learned and efficient teachers who succeed in upgrading their teaching from memory level to reflective level teaching are needed. Let us learn more about the following three levels of teaching:

- Memory level of teaching
- Understanding level of teaching
- Reflective level of teaching

5.3.1 Memory Level of Teaching

Memory is a mental process which occurs essentially in some quantity in every living being. When a person sees an object, a thing or a place, then the engrams of the object, the thing or the place are formed in his mind. To memorize these engrams

or pre-learnt things is called memory. In other words, when we see any object, then the experiences of the object go on accumulating in our unconscious mind. When we recall these accumulated past experiences and we recognize them by bringing them into our conscious mind, then that is called memory.

Definitions of Memory

Mcdougall: ‘Memory implies imagining of events as experienced in the past and recognizing them to one’s own past experience.’

J.S. Ross: ‘A memory is a new experience determined by the dispositions laid down by a previous experience, the relation between the two being clearly apprehended.’

Stout: ‘Memory is the ideal revival in which the objects or past experience restate as far as possible in the order and manner of the original occurrence.’

Woodworth: ‘Memory is the direct use of what is learned.’

Phases of Memory

The following are the phases of memory:

- Learning
- Retention
- Recall
- Recognition

(i) Learning

Memory depends upon the engrams of experiences. Hence, the first phase of memory is the learning of some facts. The task of learning is done by the conscious mind. In this phase, the life-experiences get engrammed in the brain in the form of mental impressions and these can be made conscious as and when needed. Hence, the pupils should not try to force the contents while learning something, some subject or a place. They should acquire direct knowledge. Repeat it again and again. They should search for the meaning of that idea. Memorize that knowledge by linking it with other objects or subjects.

(ii) Retention

The process of making the contents permanent in the mind is called retention. Remember that the retention power occurs differently in different individuals. A person’s memory is said to be good if he can retain a matter or an experience in his mind for a longer duration. The pupils and adolescents have more retention power as compared to the adults. It is for this reason that they memorize rapidly. According to psychologists, the retention power reaches its peak at the age of 25 years and after this it starts reducing. Remember that the retention power depends mainly upon four conditions, which are: (i) brain (ii) health (iii) interest and (iv) thinking.

Every experience leaves an impression in the brain. Our brain not only protects these impressions, but also arranges them in a sequence. These sequenced

NOTES

NOTES

impressions influence the person at every step of his life. Retention power is also closely related to the structure of the brain. Due to the differences in the structure of the brain of every person, variations in the retention power occur. As a result, some people can make impressions stabilized in their brains for a longer duration, while some can for a comparatively shorter duration.

Physical health is also deeply related to the retention power. Our nervous tissues function very conveniently when a person is in good health. Therefore, we learn very easily and quickly. This is one of the reasons that in the morning, when we feel fresh and energized, we learn things very fast. Contrary to this, when we are fatigued or stressed or in an unhealthy condition, we cannot remember or memorize something easily even if we try hard. The reason is that our nervous tissues do not work properly when we are in unhealthy conditions. Thus, our retention power lowers down.

Retention power is also related to 'interest' and 'thinking'. We remember rapidly when we have interest in something. As we are interested in that particular matter, we think about it again and again. Then, we develop a relationship with it. Thus, we learn or memorize rapidly.

(iii) Recall

The learnt matter when brought to conscious mind is called recall. Recalling of past experiences is responsible for a person's good or bad memory. If he fails to recall an experience or a matter when needed then all his learning goes in vain. Remember that those things which are not retained by proper methods, one faces difficulties while recalling them. When a person fails to recall the retained material, that enhances the chances of forgetting. Psychologists have emphasized on certain laws in order to bring learnt material at the conscious level. These laws are Law of Contiguity, Law of Similarity, Law of Contrast, Law of Continuity of Interest, Law of Primacy, Law of Recency, Law of Frequency and Law of Vividness.

(iv) Recognition

If we see an object or a person and can remember that we have seen the person or the object, it is termed as recognition. Remember that recall and recognition have similar relationship as that of brain and the body. Recalling becomes difficult when the association among objects does not occur and consequently we are unable to remember them. Contrary to this, we recognize them quickly when our association among those objects and persons becomes strong. It is our experience that we recognize people very conveniently which we meet daily and the objects which we see in our daily life. Such recognition is called definite recognition. When we recognize an object or a person partially and we are unable to tell definitely about the person, then such type of recognition is termed as partial or indefinite recognition.

Classification of Memory

People differ in the ability to memorize. Some people do not forget what they read after a single reading. Contrary to this, some people forget frequently even after reading something repeatedly. On the basis of their different abilities, memory can be classified as follows. In other words, memory is of the following types:

- **Immediate memory:** Immediate memory is that memory when a person recalls immediately after learning something. This type of memory has the following two characteristics: (a) It is temporary. It is possible that the learnt material may not retain for a longer period. (b) Its development occurs along with age. During the period of infancy, the development of the pupil is slow and somewhat faster during childhood. During adolescence, this rate of development acquires its maximum limits.
- **Permanent memory:** When a person is able to remember a learnt material for a long time, it is known as permanent memory. People, objects or places with which our association is strong are remembered for a longer duration.
- **Personal memory:** While recalling past experiences, we remember our personal past experiences. This memory is called personal memory. During the period of acquiring education, every pupil gains different experiences regarding his school, teachers and class-mates. In future, when we recall everything out of those experiences, we also recall some related personal experiences.
- **Impersonal memory:** The recalling of the material learnt from the books and companions is called impersonal memory. There is no place of personal experiences in such type of memories.
- **Active memory:** The recalling of past experiences needs some efforts, for example the candidates sitting in examination hall have to make efforts to recall the answers to the questions again and again.
- **Passive memory:** In passive memory, we recall the past experiences without any effort.
- **Mechanical memory:** Mechanical memory is also known as physical memory. When our body becomes habitual of doing any task repeatedly, then our body need not recall that task again and again. For example, a swimmer swims without any major recalling.
- **Rote memory:** Rote memory is the kind of memory in which the facts are crammed without any understanding. Such type of memory is very sharp during childhood. However, this kind of memory is not considered as a very good memory.
- **Logical memory:** To learn something by using intellect and its recalling when needed is called logical memory. This memory has been termed as true memory.

Characteristics of Good Memory

The following are the characteristics of good memory:

- **Rapidity in learning:** The first characteristic of good memory is its rapidity and simplicity in learning. Hence, the memory of a person can be called good if the person learns rapidly. Contrary to this, if a person learns slowly, his memory cannot be called good.

NOTES

NOTES

- **Stability of retention:** Another characteristic of good memory is retention of learnt material for a longer duration. The pupils are said to have a good memory if they retain what they have learnt for a longer time. Its reverse i.e. the pupils who cannot retain for a longer time are said to have bad memory.
- **Rapidity in recalling:** In addition to rapid learning and stability of retention, the third characteristic of good memory is rapidity in recalling. Those pupils are said to have good memory who can bring anything to their conscious level very rapidly. Only those pupils are said to have good memory who can recall anything according to the needs and at proper time.
- **Serviceableness:** The fourth characteristic of good memory is its score ability at some occasion. There are some pupils who possess much but when needed, they remember only irrelevant material. Contrary to this, there are pupils who can recall the appropriate material or they can identify experiences and talents according to their needs.
- **Forgetting irrelevant things:** A good memory requires forgetting of irrelevant things. Recalling of irrelevant things at the time of examination does not benefit the pupils. Similarly, recalling the painful events of life does not prove to be beneficial in any way.

Memory Level of Teaching

Light has been shed on the meaning of memory, its various stages, types and characteristics in the above description. Now it is time to classify and understand what memory level of teaching is. Remember that the memory level teaching is thoughtless. In this level of teaching, emphasis is laid on the presentation of facts and information. In other words, only rote learning of contents is emphasized by the activities of memory level teaching. It is a matter of observation that rote learning of facts of the contents has no relation with intelligence. The reason is that mentally handicapped children can also force. Yes, it is something else that if the content is purposeful, then it can be rote learned very conveniently and also can be retained for a longer duration. Hence, memory level teaching lacks insight. Almost all the pupils force the contents unwillingly. They succeed in the school examination on the basis of scores secured by rote learning but they seem to fail in the examination of life.

In short, memory level is the level of rote learning. In the teaching of this level, the facts and the information of the cognitive level are forcibly supplied to the brains of the pupils externally. Pupils recall and recognize this forcibly-retained knowledge when needed.

In reality, there is a definite pattern of memory level teaching. In this type of teaching, the teacher is like a dictator who suppresses the independence, interests, attitudes and competencies of the pupils and tries to impose the facts and information upon the pupils. Hence, in this level of teaching, the teacher remains active but the pupils go on learning by heart in strict discipline the facts and information as a passive listener. In short, no interaction occurs mechanically.

In the memory level teaching, signal learning, chain learning and stimulus-response learning are emphasized. In the end, both essay type and objective type

examinations are used to evaluate the learnt contents. The above description shows that the memory level teaching is teacher centred. Pupils have secondary place in this level of teaching. As a result, the teacher goes on imposing facts and information externally by keeping them in the strict discipline in order to develop the pupils mentally, neglecting their interests, attitudes, abilities and needs. This makes the pupils 'crammers' but they can never become intelligent and learned people. The reason is that there is no interaction between the pupils and the teacher in the memory level teaching. In short, the teaching of this level is restricted to the cognitive level which is like a burden upon pupils. The teaching of this level has the maximum level of motivation.

The evaluation of the acquired knowledge is done by traditional methods. In spite of many drawbacks, the memory level of teaching has some importance. The reason is that teaching at understanding and reflective levels can be successful only when the teaching at memory level occurs. In other words, understanding and reflective level teaching cannot take place unless and until memory level teaching has not been managed. In this way, we can say, in the understanding and reflective level teachings, memory level teaching is included and it acts as a supplement.

If we observe carefully, while teaching subjects, like Sanskrit, Grammar and History, memory level teaching is successful and impressive. The teacher has no other alternative. Still, the present educationists are trying to avoid emphasis on rote learning, but the pupil should be introduced with the basic concepts of the contents. Therefore, new mathematics has been developed in this modern age in which knowing the concepts is more emphasized instead of rote learning. But the desirable results have not been achieved in this regard.

Model of Memory Level of Teaching

Johann Friedrich Herbart is the exponent of memory level teaching. He has described the following steps while presenting the model of memory level teaching:

Levels of Teaching

- Focus
 - Syntax
 - Social system
 - Support system
- (a) **Focus:** As propounded by Herbart, the emphasis is on rote learning in the memory level teaching of evidences and progress of the following abilities:
- Remembering the learnt facts
 - Training of mental aspects
 - Recalling and re-presenting the learnt facts
 - Providing knowledge of facts
- (b) **Syntax:** The division of the memory level-teaching has been done by Herbart into five steps which is known as Herbart's Five Formal Steps. It is through these steps that the teacher can generate and produce learning situations for the memory level-teaching. Herbart's Steps are arranged as under:

NOTES

NOTES

- (i) Preparation
 - (ii) Statement of aim
 - Presentation
 - Comparison of Association
 - Generalization
 - Application
- (i) (a) **Preparation:** The very first stage of teaching is preparation. The teacher should ask the students questions related to the knowledge gained in the previous class so that the students acquire a sense of curiosity to learn new things in new ways. We can also say that the students are well prepared to acquire the new knowledge by being tested on the knowledge attained previously.
- (b) **Statement of aim:** The first step continues and this step happens to be a part of the first step. In this step, the topic to be taught to the students becomes clear to the students and the teacher performs the duty of writing those topics on the blackboard for a quick recapitulation for the students.
- (ii) **Presentation:** This step helps the students to develop a capacity for self-learning by encouraging them to use their mental capacities. The topic and the lesson is to be enhanced by the students themselves. The teacher is responsible to give as much as freedom to the students to be able to present the lesson by the students themselves which would help in building a link between the previous learnt lessons and the new lessons to be learnt.
- (iii) **Comparison and Association:** This step has been named as association by Herbart. In this step, a collective link is developed among facts, events and experiments by drawing comparisons which would help the students in understanding the lessons and topic in a better way. Hence, it is the teacher's responsibility to draw a link between two different subjects, facts and events and also of the same subject. The teacher should also draw comparisons between them so that the students are able to understand the lessons well.
- (iv) **Generalization:** This step has been named by Herbart as a system. In this step, the students are given the opportunity to ponder on the lessons learnt so that they are able communicate some laws and principles that can be used in the future.
- (v) **Application:** This is the last stage of the process of teaching. This step tests whether the new ideas acquired by the students can be used in the present situation or not. This can be carried out by asking queries regarding the lessons learnt to the students or by providing fresh forums where the student can apply the acquired knowledge. This helps in making the knowledge permanent.

- (a) **Social system:** Teaching can be said to be two-fold—social as well as professional. The adherents of this social system are: (i) the student and (ii) the teacher. In this level, the teacher is said to be authoritative and dictating. He dictates the way the students behave in the class by being active. The consequence of this step is a class of passive students who function as unresponsive listeners. Therefore, the role of the teacher is to: (i) offer the contents to the students, (ii) guiding and regulating the student's activities and (iii) motivating the students. In short, in the memory-level teaching, the teacher occupies the primary place and the pupils have secondary place. All the tasks are accomplished by the teacher and the students follow those directions considering them to be ideal.
- (b) **Support system:** Rote learning has been emphasized by the evaluation system of memory-level teaching. Because of this, while assessing the teaching at this level, both—oral and written examinations—are used. Essay-type questions in examinations are more helpful at this level of teaching, but the stages like recalling and recognition have also been used successfully via the objective type examination.

NOTES

Suggestions for Memory Level of Teaching

Memory level teaching proves to be beneficial as it provides the basic foundation for understanding level and reflective level teaching. The two levels cannot be successful without the memory level teaching. The memory level-teaching can be made effective by the following suggestions.

- The teacher should be able to accomplish the intellectual objective.
- The teacher should make it a point that the content that is to be presented to the students should be accurate and purposeful and should be in a sequence.
- The teaching point should be presented as a whole.
- Teaching should be stopped when the students are tired.
- Only whole method should be used.
- A definite strengthening system should be used.
- Recapitulation should be done in a rhythm.

5.3.2 Understanding Level of Teaching

Memory level teaching is a pre-requisition for understanding level-teaching. It is a figment of imagination to have results without this level. In this level, the teacher instructs the students in such a manner that the students are able to understand it in a proper way. In short, we can say that in the understanding level-teaching, the teacher gives full freedom to the students to avail their intellectual capabilities. This step helps the students to develop the significant skills for detail, insight and solving

intricate problems. Through this way, both the teacher and student helps in the development of the lesson.

Model of Understanding Level of Teachings

NOTES

The model of understanding level-teaching was developed by Henry C. Morrison. Therefore, this model is named as Morrison's Teaching Model. The model is arranged in the following manner by Morrison:

- Focus
- Syntax
- Social system
- Support system

(i) **Focus:** The focal point or the aim of this level-teaching according to Morrison is to understand the concept completely by the student. This focal point is emphasized by the teacher so that there is a desirable change in the behaviour of the students.

(ii) **Syntax:** This stage of the understanding level has been further classified by Morrison and a teacher can achieve the teaching-learning situation by ensuing them. There are classified as:

- Exploration
- Presentation
- Assimilation
- Organization
- Recitation

(a) **Exploration:** The following tasks have been given by Morrison under this step:

- Testing the student's previous acquired knowledge by questioning them
- Assessing the content to be delivered to the students by arranging the content in a logical sequence from the psychological point of view
- Deciding as to how the content is to be delivered and presented to the students.

(b) **Presentation:** The teacher is more active in this stage. The teacher has to carry out the following tasks for delivering the idea to the students:

- The teacher is responsible to deliver the contents in small components. He should also try to maintain the order of these divisions by building a relationship with the students.
- The teacher should make sure whether the contents delivered by him has been understood by the students or not. If the students are not able to understand, then he should make sure that he repeats the contents till they understand it.

- The teacher should recapitulate the ideas so that the students are clear about the ideas.

(c) **Assimilation:** Once the content has been provided, the teacher makes sure if the students have acquired the new lessons, and if they have acquired it then the teacher gives them the opportunity to assimilate. Assimilation consists of the following features:

- The students are given the opportunity for generalization through assimilation so that they are able to understand the concept completely.
- Assimilation is provided to the students to emphasize the significance of the content.
- During assimilation, each and every student is given the opportunity to learn the content according to his own requirement. Therefore, the teacher should give as many opportunities to the students to perform individual tasks.
- In this process, the students are encouraged to work in laboratories and libraries and are also given assignments to be completed as homework.
- In this stage, the teachers supervise the students and both students and teachers remain active in this stage. The teacher's guide the students while performing individual tasks.
- In the assimilation stage, the teacher makes sure if the students have completely understood the content delivered by him and if this does not happen, then he gives the opportunities for re-assimilation.

(d) **Organization:** According to the nature of the model, after completing the test of mastery of the content, the students now arrive at the organization or recitation period. In this stage, the students are given the opportunity to present. The students are to write the acquired ideas in their own language, through which the teacher can make out if the students have understood the content and if they can write on their own without the help of the teacher. The re-presentation in the subjects like mathematics, grammar and arithmetic has no importance. Therefore, after this they enter the stage of recitation rather to the organization.

(e) **Recitation:** This being the last stage of the understanding level-teaching, the students provide or recite the ideas acquired by the student in front of the entire class and the teacher.

(iii) **Social system:** The various stages of the social system continue altering in the understanding level of teaching. While presentation, the teacher acts as a dictator as in the memory level by controlling the behaviour of the students, as well as provides motivation to the students. In the stage of assimilation, both—the teacher and the students—are active. The teacher only provides some essential directions and the students work on their own with full

NOTES

NOTES

dedication. Therefore, in this level, both intrinsic as well as extrinsic motivation is provided to the students.

- (iv) **Support system:** Similar to the social system, here too the system does not remain stagnant but continue changing. The students are required to perform well in the examination of presentation, only then they are able to carry out experiments in assimilation. Moreover, the students are also required to perform well in the assimilation test to be able to enter the stages of organization and recitation. A written test is carried out at the end of the organization stage, after which the recitation stage is carried out through an oral test. Therefore, both—written and oral test—are carried out in the various stages of the understanding level-teaching.

Limitations of Understanding Level Model

The limitations of understanding-level model, as given by Morrison, are as follows:

- Since it places more emphasis on the content of the learning material, the human behaviour gets ignored.
- The model is unable to help in evolving emotional and psychomotor facets.

Suggestions for Understanding Level of Teaching

The understanding level-teaching can be made more effective by following the suggestions provided by Morrison. These suggestions are:

- The students should be allowed to enter this level only if they are able to clear the tests of the memory level-teaching.
- Each and every stage of this level should be carried out in its proper order.
- The students should be promoted to the next stage of this level only if they have qualified in the previous stage. For example, they should be promoted to the assimilation stage only if they have qualified the presentation stage.
- The teacher's role is to motivate the students emotionally as well as academically. He should be able to raise the level of aspiration of the students.
- The teacher should help the students in solving the problems related to understanding level-teaching.

CHECK YOUR PROGRESS

4. Define the term 'memory' as per Stout.
5. Identify the important phases of memory.
6. What do you understand by immediate memory?
7. List some of the popular methods that can make 'memory-level' teaching effective.
8. What do you understand by the 'focus of memory level teaching'?

5.3.3 Reflective Level of Teaching

Reflective level of teaching includes both the understanding and memory-level teaching. Reflective level of teaching does not succeed if the teaching of memory and understanding levels have not taken place earlier. Hence, the management of teaching at the memory and understanding levels should have taken place before the reflective level-teaching starts. The reflective level-teaching is also termed as the 'problem-centred' teaching. In this level, the classroom is an open space where its environment is open adequately. Here, the teacher creates such a problematic situation in the class that the students under mental tension begin solving their problems by articulating and testing their hypothesis which is a resultant of their own motivation. At the end, a time comes when the problem is solved by the students. In other words, the reflective level-teaching helps in the development of creative skills and abilities by helping the students in developing their intellectual capacities.

Human life is a struggle and hence the students have to achieve the best for which they need to perform the best. There are times when the student achieves his aim without any obstacles in his way, in a natural way but there are times when they have to face several obstacles to achieve their aims and aspirations. Viewing this in mind, the teachings provided by the reflective level-teaching are very essential for the students as it helps in the development of the reflective power. When this reflective power enhances with the passage of time, the students will be able to tackle their own problems of life by reasoning out their problems which will help them in leading a happy and successful life. In short, the pupil learns to develop his original attitude as a result of his deep and serious study in order to solve his problem. This enables him to solve his future life problems successfully through reasoning, logic and imagination. M. L. Bigge has rightly pointed out that, 'Reflective level of teaching tends to develop the class-room atmosphere which is more alive and exciting, more critical and penetrating and more open to fresh and original thinking.' Also, the type of enquiry carried out by the reflective level tend to be more demanding and producing than the memory and understanding level.

Model of Reflective Level of Teaching

Tristram Hunt is credited for the development of the reflective level of teaching. Hence, this model is also termed as Hunt's Model of Teaching. This model has been classified by Hunt as:

- Focus
 - Syntax
 - Social system
 - Support system
- (i) **Focus:** This level of teaching has the following three objectives:
- To enhance the problem-solving capabilities of the students
 - To help in the development of critical and productive thinking among the students

NOTES

NOTES

- To help in the development of novel, independent and original thinking capability among the students

(ii) **Syntax:** The syntax of the reflective level-teaching has been designed as:

- A problematic situation is created by the teacher before the students.
- In the second stage, the students articulate the hypothesis for testing. It may happen that more than one hypothesis is provided by the students for the solution of a problem.
- Then the students collect data to verify the hypothesis. This collected data would help in deciding whether the hypothesis is helpful in providing a solution to the problem or not.
- In the last step, the testing of the hypothesis is done. The results are then declared with regard to these tests which are actually the original ideas of the students.

(iii) **Social system:** In this level of teaching, the student acquires the primary place and the teacher acquires the secondary position in the classroom. In this level, the teacher is required to perform the following functions:

- To present a problematic situation before the pupil
- To enhance the quality of the teaching-learning process by encouraging discussion and seminars among the students in the classroom
- To motivate the students and guide them

Since the students become sensitive for solving the problems, both—self-motivation and social motivation—have equal significance.

(iv) **Support system:** In this level of teaching, objective-type questions in the examination does not help. Students can be evaluated properly only by assessing their abilities through essay-type questions in the examination. While evaluating reflective method:

- The outlook and views of the students should be evaluated
- Their participation in the class activity should be evaluated
- The development of the creative and critical capabilities should also be evaluated

Characteristics of Reflective Level of Teaching

The characteristics of the reflective level of teaching as provided by Hunt are as follows:

- Similar to the memory and understanding level of teaching, this level too does not follow any definite programme.
- In the reflective level of teaching, only group-discussion method is considered to be effective.
- This level of teaching cannot be limited only to the curriculum, contents and text books.

Suggestions for Reflective Level of Teaching

To make the reflective level-teaching effective, certain suggestions were provided by Hunt. They are:

- The students should be allowed to enter this level only if they are able to clear the tests of the memory and understanding levels of teaching.
- It is essential that the teacher follows all the four steps of the reflective type-learning.
- The teacher should motivate the students as much as possible and also raise the level of aspiration so as to make this level a success.
- There are ways by which the weaknesses of the teacher can be eliminated, like the emphasis on the cognitive field of psychology.
- Teachers should develop a problematic situation before the students so that they develop the skill of original and creative thought.
- The environment of the classroom should be free so that the students are able to participate actively in the discussion so as to solve the problems.

NOTES

CHECK YOUR PROGRESS

9. What are the five steps of the 'syntax' of understanding level teaching?
10. What are the limitations of teaching at understanding level?
11. What are the three objectives of the reflective level of teaching?
12. State at least five suggestions presented by Hunt to make the reflective level of teaching more effective.

5.4 PROGRAMME INSTRUCTION

Programmed learning/instruction is a revolutionary strategy pertaining to the art and science of the teaching-learning process. In our country there have been attempts for the use of programmed instructions especially in providing materials to the students of correspondence courses. Suitable self-instructional programmed materials for different subjects and grades have been prepared and it is being used for instructional and self-instructional purposes. Besides, its use for instructional purpose, programmed instruction has full potentiality for being used as a mechanism of feedback-device for the modification of teacher behaviour and improving teaching efficiency.

It nevertheless provides insight into the problem of teaching effectiveness through improved feedback and reinforcement mechanism. Programmed learning is an educational innovation and auto-instructional device. It is a practice of breaking down a body of subject-matter into its constituent elements and requiring the pupil to master one step before proceeding to the next. It allows for more pupil involvement in the learning process. As it is a self-instructional device, it is mostly individualized being adapted to individual differences. In this technique, learning is more rapid as

well as interesting. It is directed towards specific objective and retained better as well as longer.

Origin of Programmed Instruction

NOTES

Modern programmed instruction originated from the psychology of learning and not from technology. It is an application of the Conditioning theory to teaching learning process. It got a momentum only after the publication of B.F. Skinner's *The science of learning and art of teaching* in 1954.

Programmed instruction, in an advanced form of teaching machine, was initiated by Prof. Sidney L. Pressey.

Meaning and Definition of Programmed Instruction

Programmed instruction can be defined as a teaching method where individualized instructions are provided to students. In this method, the students are provided with immediate result. The physical presence of teacher is not essential in this strategy. According to Susan Markle, 'It is a method of designing a reproducible sequence of instructional events to produce a measurable and consistent effect on behaviour of each and every acceptable student.'

Thus, programmed learning is a strategy in which various kinds of intellectual, emotional and motor experiences are provided to the learner, in a controlled situation, through a variety of devices like a book, teaching machine, teacher, radio and television.

Definitions by Experts

W. I. Smith and J. W. Moore, editors of the book *Programmed Learning: Theory and Research*, define programmed instruction as, 'Programmed instruction can be defined as the process of arranging the material to be learned into a series of sequential steps. Usually it moves the students from a familiar background into a complex and new set of concept, principles and understanding.'

Walter Barnard who contributed to the book *Guidance in the Classroom*, defines it as, 'Programmed learning refers to the arrangement of instructional material in progressive sequences.'

Behaviourist B. F. Skinner defines it as, 'Programmed learning is the first application of laboratory technique utilized in the study of the learning process to the practical problems of education.'

G. O. M Leith author of *Handbook of Programmed Learning*, defines it as, 'A programme is a sequence of small steps of instructional material (called frames), most of which requires a response to be made by completing a blank space in a sentence. To ensure the required responses we given, a system of cueing is applied, and each response is verified by the provision of immediate knowledge of results. Such a sequence is intended to be worked at the learners own pace as individualized self instruction.'

Wilbur Schramm, author of *Programmed Instruction*, defines as, 'By programmed instruction, it means the kind of learning experiences in which a programme takes the place of a tutor for the student and leads him through a set of behaviour, designed

in sequences to make it more probable that he behaves in a given desired way in the future. In other words, he will learn what the programmes designed to teach him.'

Assumptions of Programmed Instruction

Programmed instruction assumes that a student learns better under the following situation:

- By being active
- If he is motivated to learn by confirming his responses
- If the content-matter is presented in small steps
- If he commits minimum errors in his learning
- If the sequence of content is psychological
- If the pre-requisites are specified on the part of the learner

Objectives of Programmed Instruction

The objectives of programmed instruction are:

- To help student to learn by himself
- To provide a situation to learn at his own pace
- To help student to learn without the presence of a teacher
- To present the content in a controlled manner and in logically sequenced steps
- To assess his own performance by comparing it with the given answer

Characteristics of Programmed Instruction

The characteristics of programmed instruction are:

- It is not an audio-visual device. It is a part of education technology, i.e., instructional technology.
- It is not a test but a new strategy for teaching and learning.
- It is not the solution of educational problems but a new instructional strategy for the modification to behaviours of the learners.
- It cannot replace the teacher from the field of teaching but an effective teacher can prepare a good programme.
- It requires more creativity and imaginative efforts to develop highly individualized instruction.

5.4.1 Steps for Development of Programmed Instruction

The steps for development of programmed instruction are:

- Selection of the topic to be programmed
- Identifying the objectives
- Content analysis for developing the instructional procedure
- Writing objectives (Entering and Terminal) in behavioural terms

NOTES

NOTES

- Construction of criterion test
- Deciding appropriate paradigm and strategy of programme
- Writing programme frames
- Revising and editing the programme and preparing the final draft
- Master validation or evaluation of the programme in terms of internal and external criteria
- Preparation of a manual of the programme

Topic selection

The programmer should select the most familiar topic; otherwise he has to take the help of a subject expert. He may confine himself to selecting a specified content or a small area of the subject matter.

Content outlines

After topic selection, its outlines may be prepared which should cover all the materials one plans to teach. For this the programme has to refer to and examine relevant books and materials.

Instructional objectives

The instructional objective must be formulated which involves both test descriptions and task analysis. The former is the description of terminal behaviour which the learner is expected to achieve and the latter is the series of component behaviour that is required to acquire in the process of achieving terminal behaviour. The instructional objectives should be written in behavioural outcomes.

Entry skill

The learner should have some prerequisite ability and skill to understand properly the new programme. This background experience is called the entry skill, and a suitable programme cannot be prepared without proper assessment of the entry skill. To prepare a programme adequately, target-oriented entry skill data should be utilized at this stage.

Presentation of the material

Suitable format is to be decided for presenting the material from the educational point of view. Then the programmed material should be presented in a sequence of frames arranged as steps towards terminal behaviour.

Student participation

On analysis of the terminal behaviour, he will find the critical responses of the students. Of course, it is related to some part of the subject-matter. The overt responses facilitates student learning. Students' participation is facilitated by presenting the programme in an interesting format.

Terminal behaviour test

The effect of the programme can be ascertained by administering the terminal behaviour test, also known as performance assessment. This provides feedback to the programme and shows the effectiveness of the instructional materials. It may also serve as an entry skill data for the next programme on a related topic of higher levels.

Revision

Lastly, the programme may be reviewed on the basis of feedback. The instructional materials may be edited and modified according to the needs and requirements of the target audience.

The procedure of programmed instruction provides a deep insight and understanding of the elements, structure and their sequence. During teaching practice, the pupil-teachers are asked to teach a lesson by following the traditional approach of lesson planning. The classroom teaching is recorded or evaluated. Now they are asked to develop the programmed instruction frames on the same topic and asked to re-teach the same topic to another class of the same level. The same criterion measure should be used to record and evaluate classroom teaching. Experimental studies of this type have yielded significant improvement in teaching. The preparation of the programmed frames provides awareness about the content, structure and function as feedback to the trainee. The following skills are developed by the training of the programmed instruction:

- The pupil-teachers skills of content analysis and arranging content in learning sequence.
- The pupil-teachers skill to present the content into small steps.
- The pupil-teachers skill to provide the reinforcement to learn by confirming their responses.
- The pupil-teachers skill to develop the situation for achieving the desired learning objectives.
- The trainees skill to consider the individual variation and generate the learning situation that they can learn according to their own pace.
- The pupil-teachers skill to identify the objectives and are able to write them in behavioural term.

5.4.2 Fundamental Principles

A good programmed instruction is based upon the principles of learning. The principles, on which programmed instruction is based, are discovered in psychological laboratories. There are five fundamental principles of programmed instruction. They are as follows:

(i) Principle of small steps

The subject matter is broken down into a sequence of small steps. A student can take a step at a time. He has to read a small step by being active. This small part of

NOTES

NOTES

the information is known as a frame.

(ii) Principle of active responding

Programmed instruction is based on the principle of active response. A student learns better if he actively participates in the learning process and he learns best if he actively responds while learning.

(iii) Principle of immediate confirmation

Students learn better if their answers are confirmed immediately. Therefore, immediate confirmation serves as a kind of motivation or reinforcement.

(iv) Principle of self-pacing

In programmed instruction, each student proceeds at his own pace. It is common knowledge that some students naturally learn more rapidly or more stoutly than others. One learns most effectively if he learns in his own pace. In programming, each student can work each step as slowly or as quickly as he can. This principle is based on individual differences in the process of teaching. This is known as principle of self-pacing.

(v) Principle of student-testing

Constant evaluation is yet another fundamental principle of programmed instruction. It helps students to learn and grasp the material given in each frame. The aim of this arrangement is not to test the student but to improve the quality of programmed materials through checking the number of errors at each step. A student leaves the record of his study because he has to write a response for each step on a response sheet.

CHECK YOUR PROGRESS

13. What is programmed learning?
14. When and how did the programmed instruction get a momentum?
15. What is a frame?

5.5 TYPES OF PROGRAMMED INSTRUCTION

Programmed instruction can be of the following types:

(i) Linear Programming

Linear programming was developed by B. F. Skinner and is considered one of the most important types of programmed learning. Its basis is psychology. Linear programming is also known as extrinsic programming. This method presents stimulus-response bond. In this type of programmed learning, the questions are directly asked to the pupils. Then, they are instructed to think and write answers to those questions. Such types of responses are known as 'constructed response'.

Linear programming is a programme designed in a straight line in which the pupil starts from his initial behaviour to the terminal behaviour following a straight line. In this way the pupil moves from one frame to the other frames till he completes the entire programme. The subject matter is broken into various small units which are arranged in a proper sequence. Immediate feedback is provided to the pupil. A bit of information is given in each frame and this programming is also known as skinnerian programming.

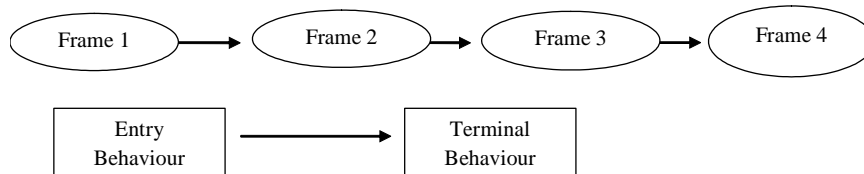

Fig. 5.1 Path of Learning: Arrangement of frames in Linear Programming

Characteristics of Linear Programming

The characteristics of linear programming are:

- It is called a linear programme because there is only one way or line to follow.
- A student goes from one frame to the other till the entire programme is over.
- In the linear programming, constructive (fill-in the blanks) responses are mostly used.
- Students are provided with stimulus or signals at the initial stage of the programme.
- The entire programme consists of many smaller frames and each frame contains a single idea, example or rule.

Limitations of Linear Programming

The limitations of linear programming are:

- It is a very costly method and consumes a lot of time.
- In this method, the freedom of the pupil is restricted.
- This method is helpful in providing knowledge related to the lower level of the cognitive domain, e.g. knowledge of some facts.
- It is a difficult job to produce a programmed material of higher level.
- It is not helpful in producing material for all the school subjects.

(ii) Branching Programming

Branching programming is also known as the Crowderian programming. It can be defined as: 'A programme which adapts to the needs of the students without the medium of extrinsic device as a computer. It is also known as intrinsic programming as the learner himself makes the decision to adapt the instructions to his/her needs.'

In comparison to linear programming, the frame size and amount of information given is more and is followed by multiple choice types of questions. If the learner

NOTES

NOTES

chooses the correct answer, he is informed of the correctness of the answer and is motivated to proceed to the next frame along the main path of learning of the programme. If the answer is wrong the learner is told why he/she is wrong and he/she either goes back to the main line or he/she is routed back to the original frame to reread along a remedial frame till he chooses the right answer. In branching programming, frames are presented in book form, it is known as 'scrambled book.'

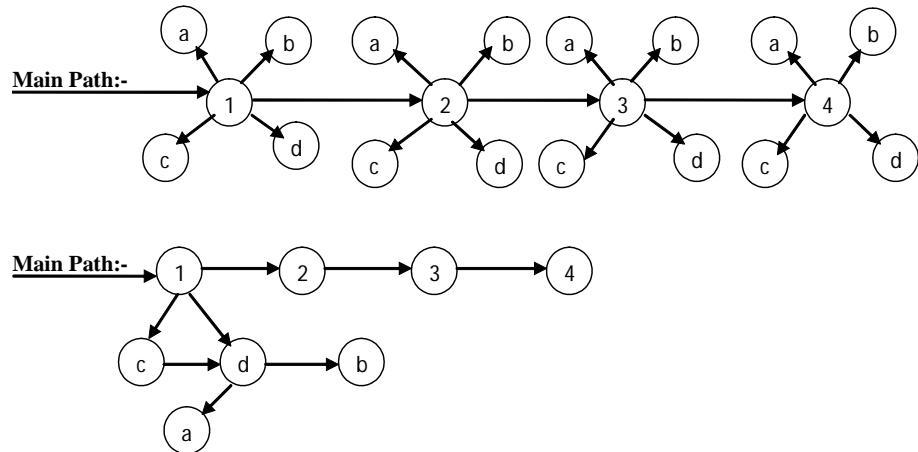

Fig. 5.2 Arrangement of Frames in Branching Programming

Characteristics of Branching Programming

The characteristics of branching programming are:

- The pupils are free for their responses. They can select any answer out of the multiple alternatives and move towards next frame on the basis of that response.
- There is a provision of remedial instruction for the errors committed by the pupils.
- In such type of programming there is much emphasis on paying attention towards the difficulties of the pupils.
- This method is used to achieve the higher-order teaching objectives.
- In this method each pupil determines his own method of study.

Limitations of Branching Programming

The limitations of branching programming

- The multiple choice questions provided in this programme may encourage guessing without understanding the subject matter of the frame.
- The setting of appropriate multiple choice questions suiting to the whole material of the frames proves to be a difficult task.
- The branching programme assists to cater to the needs and individual differences of all the learners. It requires infinite branching which is not feasible.

- The branching programme is a costly affair. The cost of preparation of a programme in a printed book form or audio-visual material is quite high as the programme needs frequent revision.

(iii) Mathetics Programming

Mathetics programming was developed by Thomas F. Gilbert. The term is derived from the Greek word 'Mathein' which means learning.

Linear programming is associated with the change in behaviour, branching programming with providing remedy, and mathetics with gaining mastery of the subject. Mathetics programming is also known as backward chaining or retrogressive chaining.

A mathetics programme begins with an instructional plan and an analysis of what is to be taught. Gilbert emphasizes that the analysis must concentrate on learner activity and not subject matter coverage. However, mathetical programming may be applied to any subject. The emphasis on task simulation makes it a particularly suitable vehicle for teaching skills where transfer of training forms an essential part of instruction.

One of the basic concepts of mathetics is to start with the most motivating task which generally, is the last or final step in any task. Hence, the learner starts from the last task and goes backward to finally reach the introductory part. The tasks or frames have to be carefully chained otherwise they will lose relevance, sequence and logic.

Characteristics of Mathetics Programming

The characteristics of mathetics programming are:

- By this strategy of instructions, opportunities can be provided to the students to learn from their responses.
- It is convenient to make the students understand by presenting the subject matter to them in small steps or units.
- By this strategy, even in the absence of a teacher, the pupils can gain mastery on the subject matter.
- In this, the pupils get reinforcement by confirming their responses. Hence, completion of the task is considered as a source of reinforcement.
- By this method, chain, dissemination and generalization are used in learning.
- In this strategy, importance is given to the mastery on subject matter.
- In this programming, mastery on subject matter is encouraged by using retrogressive chaining sequence.

Limitations of Mathetics Programming

The limitations of mathetics programming are:

- All types of subject matters cannot be presented. Hence, its application is very limited.

NOTES

NOTES

- The process of preparing this programme is difficult.
- All the students are required to study under one sequence or programme by ignoring the needs of the pupils.
- It is impossible to achieve higher objectives by applying this method.
- There is no provision of remedial teaching for the pupils in this method.

Programmed instruction is a self-instructional material developed on the psychological principles of teaching-learning process. A rapid learner can cover the material quickly and a slow learner may proceed on his own pace. This frees the learners from the same type of teaching materials delivered to the whole class at the same pace. The programmed learning material helps the learner to teach himself at any place and pace according to his convenience. Different types of programmes have their special advantages and facilitate learner's initiative participation and involvement according to their interests and ability. They provide scientific teaching and learning for efficient and effective acquisition of knowledge and skills. The analytical thinking and self-direction of learners are also promoted through the use of programmed learning materials.

CHECK YOUR PROGRESS

16. What is the basis of linear programming?
17. List two limitations of linear programming.
18. Define branching programming.
19. What is the basic concept of mathematics?
20. List two characteristics of mathematics programming.

5.6 SUMMARY

- Teaching is not a single activity. It can be interpreted in its molecular form. It can be viewed as a family of activities. In this family of activities, every activity becomes important.
- Teaching and training are not alike. Training is a part of teaching. The more the intelligence exhibited in the training programme, more it would be closer to the teaching-process and would resemble teaching.
- Whenever we happen to provide instruction or guidance, it means we are performing the task of teaching. But when we teach, it is not necessary that instruction too is included in that teaching.
- Indoctrination is the highest level of teaching. At this level more intelligence is expected. All the great men, politicians, leaders influence other people with the support of their ideology, thoughts, assumptions and beliefs.
- A teacher can present the content at three levels, from thoughtless to thoughtful situations. These levels are: (i) Memory level (ii) Understanding level and (iii) Reflective level.

- Memory is a mental process which occurs essentially in some quantity in every living being. When a person sees an object, a thing or a place, then the engrams of the object, the thing or the place are formed in his mind. To memorize these engrams or pre-learnt things is called memory.
- The learnt matter when brought to conscious mind is called recall. Recalling of past experiences is responsible for a person's good or bad memory.
- The memory level teaching is thoughtless. In this level of teaching, emphasis is laid on the presentation of facts and information.
- Herbart has divided the memory level-teaching into five steps which are known as Herbart's Five Formal Steps. By following these five steps a teacher can create learning situations for memory level teaching.
- In understanding-level teaching, the teacher tries to provide more and more opportunities to develop the intellectual behaviours of the pupils. This develops the essential competencies for generalizations, insight and solving the problems.
- The model of understanding level teaching was indoctrinated by Morrison. Hence it is named as Morrison's Teaching Model.
- Reflective level of teaching includes both understanding and memory-level teaching. Reflective level of teaching does not succeed if the teaching of memory and understanding levels have not taken place earlier.
- The credit goes to Hunt for developing reflective level of teaching. Therefore, this teaching model is named as Hunt's Model of Teaching.
- Programmed learning/instruction is a revolutionary strategy pertaining to the art and science of the teaching-learning process.
- Modern programmed instruction originated from the psychology of learning and not from technology. It is an application of the Conditioning theory to teaching learning process.
- Linear programming was developed by B. F. Skinner and is considered one of the most important types of programmed learning. Its basis is psychology. Linear programming is also known as Extrinsic Programming.
- Linear programming is a programme designed in a straight line in which the pupil starts from his initial behaviour to the terminal behaviour following a straight line.
- Branching programming is also known as the Crowderian programming. It can be defined as: 'A programme which adapts to the needs of the students without the medium of extrinsic device as a computer. It is also known as intrinsic programming as the learner himself makes the decision to adapt the instructions to his/her needs.'
- Mathematics programming is developed by Thomas F. Gilbert. The term is derived from the Greek word 'Mathein' which means learning.

NOTES

NOTES

5.7 KEY TERMS

- **Teaching:** Teaching may be defined as a system of actions directed to pupils.
- **Retention:** The process of making the contents permanent in the minds is called retention.
- **Recognition:** If we see an object or a person and can remember that we have seen the person or the object, it is termed as recognition.
- **Permanent memory:** The recalling of learnt material for a longer time is known as permanent memory.
- **Personal memory:** While recalling past experiences, we remember our personal past experiences. This memory is called personal memory.
- **Impersonal memory:** The recalling of the material learnt from the books and companions is called impersonal memory.
- **Rote memory:** Rote memory is the kind of memory in which the facts are crammed without any understanding.
- **Logical memory:** To learn something by using intellect and its recalling when needed is called logical memory.
- **Programmed instruction:** Programmed instruction can be defined as a teaching method where individualized instructions are provided to students. In this method, the students are provided with immediate result. The physical presence of teacher is not essential in this strategy.
- **Branching programming:** Branching programming is, 'A programme which adapts to the needs of the students without the medium of extrinsic device as a computer. It is also known as intrinsic programming as the learner himself makes the decision to adapt the instructions to his/her needs.'

5.8 ANSWERS TO 'CHECK YOUR PROGRESS'

1. According to Israel Scheffler, 'Teaching may be characterized as an activity aimed at the achievement of learning and practiced in such a manner as to respect the student's intellectual integrity and capacity for independent judgment.'
2. Training is a part of teaching. The more the intelligence exhibited in the training programme, more it would be closer to the teaching process and would resemble teaching. Actually training resembles more with conditioning than teaching. In short, the main difference between training and teaching is reflected by the quantity of intelligence used. In the process of training, the acquisition of new turn to the human behaviour and the acquisition of various skills are helped.

3. Indoctrination is the highest level of teaching. At this level more intelligence is expected. Great men, politicians and leaders influence other persons with the support of their ideology, thoughts, assumptions and beliefs. The teacher can include indoctrination in his teaching.
4. According to Stout, memory can be defined as ‘the ideal revival in which the objects or past experience reinstate as far as possible in the order and manner of the original occurrence.’
5. Some of the important phases of memory are as follows:
 - Learning
 - Retention
 - Recall
 - Recognition
6. When a person recalls immediately after learning something, the memory is called immediate memory.
7. Some of the popular methods that can make memory level teaching effective are:
 - The teacher should try to achieve the cognitive objective.
 - The content to be presented should be purposeful.
 - The teaching points should be presented as a whole or in to.
 - The content should be presented in a sequence.
 - There should be no teaching when the pupils are tired.
8. According to Herbart, the focus of memory level teaching is the emphasis on rote learning of facts and development of the following capacities:
 - Training of mental aspects
 - Providing knowledge of facts
 - Retaining the learnt facts
 - Recalling and re-presenting the learnt facts
9. Morrison has divided the syntax of understanding level teaching into five steps. The steps are as follows:
 - Exploration
 - Presentation
 - Assimilation
 - Organization
 - Recitation
10. The limitations of understanding level model are as follows:
 - It stresses upon the mastery of the content. Hence, human behaviour is overlooked.
 - It does not help in developing affective and psychomotor aspects.

NOTES

NOTES

11. The three objectives of the reflective level of teaching are as follows:
 - To develop problem-solving competency among pupils
 - To develop critical and constructive thinking among pupils
 - To develop independent and original thinking power among pupils
12. The five suggestions presented by Hunt to make the reflective level of teaching more effective are:
 - Teacher should allow the pupils' entry into the reflective level of teaching who succeed in the tests of memory and understanding levels of teaching.
 - In the reflective level of teaching, the teacher should follow all the four steps of this level observing the precautions.
 - The teacher should raise the level of aspiration of the pupils.
 - In order to eliminate the weaknesses of the teacher, cognitive field psychology should be stressed.
 - The teacher should create problems before the pupils so that original and creative thinking may develop in them.
13. Programmed learning/instruction is a revolutionary strategy pertaining to the art and science of the teaching-learning process.
14. Programmed instruction got a momentum only after the publication of B. F. Skinner's *The science of learning and art of teaching* in 1954.
15. The subject matter is broken down into a sequence of small steps. A student can take a step at a time. He has to read a small step by being active. This small part of the information is known as a frame.
16. Linear programming was developed by B. F. Skinner and is considered one of the most important types of programmed learning. Its basis is psychology. Linear programming is also known as Extrinsic Programming.
17. The limitations of linear programming are:
 - It is a very costly method and consumes a lot of time.
 - In this method, the freedom of the pupils is restricted.
18. Branching programming is 'A programme which adapts to the needs of the students without the medium of extrinsic device as a computer. It is also known as intrinsic programming as the learner himself makes the decision to adapt the instructions to his/her needs.'
19. One of the basic concepts of mathematics is to start with the most motivating task which generally is the last or final step in any task. Hence the learner starts from the last task and goes backward to finally reach the introductory part.
20. The characteristics of mathematics programming are:
 - By this strategy of instructions, opportunities can be provided to the students to learn from their responses.
 - It is convenient to make the students understand by presenting the subject matter to them in small steps or units.

5.9 QUESTIONS AND EXERCISES

Short-Answer Questions

1. Distinguish between teaching and indoctrination.
2. What is the difference between teaching and instruction?
3. List the different types of memory.
4. Write a note on retention as a phase of memory.
5. What are the characteristics of memory?
6. Identify Herbart's Five Formal Steps.
7. Write a note on Morrison's teaching model.
8. List some of the important suggestions which can help improve the understanding level of teaching.
9. Write a brief note on reflective level of teaching.
10. What are the limitations of reflective level of teaching?
11. How did programmed instruction originate?
12. What are the steps for the development of programmed instruction?
13. List the fundamental principles of programmed instruction.
14. What is linear programming? What are its characteristics?
15. List the limitations of mathematics programming.

Long-Answer Questions

1. Discuss the concept of teaching and differentiate it from instruction, training and indoctrination.
2. What are the different levels of teaching? Explain the memory level of teaching.
3. Assess the process of understanding level of teaching.
4. Critically analyse the process of reflective level of teaching.
5. Evaluate the process of programme instruction.
6. Discuss the types of programmed instruction.

5.10 FURTHER READING

- Aggarwal, J. C. 2009. *Essentials of Educational Technology*. New Delhi: Vikas Publishing House.
- Kochhar, S. K. 1985. *Methods and Techniques of Teaching*. New Delhi: Sterling Publishers.
- Mangal, S. K. 2001. *Foundation of Educational Technology*. Ludhiana: Tendon Publications.

NOTES

NOTES

Sampath, K., A. Panneerselvam, S. Santhanam. 2007. *Introduction to Educational Technology*. New Delhi: Sterling Publishers.

Shankala, D.P. 2006. *Educational Technology*. New Delhi: Adhyayan Publishers and Distributors.

Sharma, K. K. 2007. *Educational Technology*. Delhi: Mahaveer & Sons Publishers and Distributors.

Sharma, R. A. 2002. *Technology of Teaching*. Meerut: International Publishing House.

NOTES

NOTES